



**AGENDA OF A REGULAR MEETING - NATIONAL CITY CITY COUNCIL/
COMMUNITY DEVELOPMENT COMMISSION – HOUSING AUTHORITY OF
THE CITY OF NATIONAL CITY**

**COUNCIL CHAMBERS
CIVIC CENTER
1243 NATIONAL CITY BOULEVARD
NATIONAL CITY, CALIFORNIA
TUESDAY, SEPTEMBER 17, 2013 – 6:00 PM**

RON MORRISON
Mayor

LUIS NATIVIDAD
Vice Mayor

JERRY CANO
Councilmember

MONA RIOS
Councilmember

ALEJANDRA SOTELO-SOLIS
Councilmember

**1243 National City Blvd.
National City, CA 91950
619-336-4300**

**Meeting agendas and
minutes available on web**

WWW.NATIONALCITYCA.GOV

ORDER OF BUSINESS: Public sessions of all Regular Meetings of the City Council / Community Development Commission - Housing Authority (hereafter referred to as Elected Body) begin at 6:00 p.m. on the first and third Tuesday of each month. Public Hearings begin at 6:00 p.m. unless otherwise noted. Closed Sessions begin at 5:00 p.m. or such other time as noted. If a workshop is scheduled, the subject and time of the workshop will appear on the agenda. The Mayor and Council members also sit as the Chairperson and Members of the Board of the Community Development Commission (CDC).

REPORTS: All open session agenda items and reports as well as all documents and writings distributed to the Elected Body less than 72 hours prior to the meeting, are available for review at the entry to the Council Chambers. Regular Meetings of the Elected Body are webcast and archived on the City's website **www.nationalcityca.gov**.

PUBLIC COMMENTS: Prior to the Business portion of the agenda, the Elected Body will receive public comments regarding any matters within the jurisdiction of the City and/or the Community Development Commission. Members of the public may also address any item on the agenda at the time the item is considered by the Elected Body. Persons who wish to address the Elected Body are requested to fill out a "Request to Speak" form available at the entrance to the City Council Chambers, and turn in the completed form to the City Clerk. The Mayor or Chairperson will separately call for testimony of those persons who have turned in a "Request to Speak" form. If you wish to speak, please step to the podium at the appropriate time and state your name and address (optional) for the record. The time limit established for public testimony is three minutes per speaker unless a different time limit is announced. Speakers are encouraged to be brief. The Mayor or Chairperson may limit the length of comments due to the number of persons wishing to speak or if comments become repetitious or irrelevant.

WRITTEN AGENDA: With limited exceptions, the Elected Body may take action only upon items appearing on the written agenda. Items not appearing on the agenda must be brought back on a subsequent agenda unless they are of a demonstrated emergency or urgent nature, and the need to take action on such items arose after the agenda was posted.

Upon request, this agenda can be made available in appropriate alternative formats to persons with a disability in compliance with the Americans with Disabilities Act. Please contact the City Clerk's Office at (619) 336-4228 to request a disability-related modification or accommodation. Notification 24-hours prior

to the meeting will enable the City to make reasonable arrangements to ensure accessibility to this meeting.

Spanish audio interpretation is provided during Elected Body Meetings. Audio headphones are available in the lobby at the beginning of the meeting.

Audio interpretación en español se proporciona durante sesiones del Consejo Municipal. Los audiófonos están disponibles en el pasillo al principio de la junta.

COUNCIL REQUESTS THAT ALL CELL PHONES AND PAGERS BE TURNED OFF DURING CITY COUNCIL MEETINGS.

OPEN TO THE PUBLIC

CITY COUNCIL / COMMUNITY DEVELOPMENT COMMISSION AGENDA

CALL TO ORDER

ROLL CALL

PLEDGE OF ALLEGIANCE TO THE FLAG

PUBLIC ORAL COMMUNICATIONS (THREE-MINUTE TIME LIMIT)

PROCLAMATIONS

1. Proclaiming September 17 through September 23, 2013 as: "Constitution Week"

PRESENTATIONS

2. Employee of the Quarter 2013 - Rustico "Rusty" Aguilar, Custodian
3. Recognizing Miguel Diaz, Park Superintendent on his 30 years of service with the City of National City.
4. Unified Port of San Diego Update - Port Commissioner Robert (Dukie) Valderrama

INTERVIEWS / APPOINTMENTS

5. Interviews and Appointments: Various Boards / Commissions / Committees. (City Clerk)

CONSENT CALENDAR

6. Approval of the Minutes of the Adjourned Regular Meetings of the City Council and Community Development Commission - Housing Authority of the City of National City of June 11, 2013 and August 6, 2013 and the Minutes of the Special Meeting of the City Council and Community Development Commission - Housing Authority of the City of National City of August 6, 2013 (City Clerk)
7. Resolution of the City Council of the City of National City authorizing the Mayor to execute a Fourth Amendment to the Agreement for Legal Services by Best Best & Krieger, LLP, for the Community Youth Athletic

- Center legal challenge defense to increase the not to exceed amount by \$53,500 for a total not-to-exceed amount of \$462,500. (City Attorney)
8. Resolution of the City Council of the City of National City adopting a Safe Harbors under the Patient Protection and Affordable Care Act. (Human Resources)
 9. Resolution of the City Council of the City of National City reaffirming the Phase III Expansion of the San Diego Convention Center. (City Manager)
 10. Resolution of the City Council of the City of National City, 1) awarding a contract in the not to exceed amount of \$3,524,896.00 to EC Constructors, Inc. for the National City Aquatic Center Project, Specification No. 13-04; 2) authorizing a 15% contingency in the amount of \$528,734.40 for any unforeseen changes; and 3) authorizing the Mayor to execute the contract (funded by San Diego Unified Port District CIP). (Engineering)
 11. Resolution of the City Council of the City of National City authorizing the Mayor to execute an Encroachment Permit and Agreement between the City of National City and Nagraj, Inc. (APN 557-410-19), whereby the City grants an aerial encroachment over a portion of public right-of-way located at 1700 E. Plaza Boulevard. (Engineering)
 12. Resolution of the City Council of the City of National City authorizing the Mayor to sign an Indemnity Agreement relating to Fire/Police training operations, by and between the City of National City and Costco Wholesale Corporation, Owners of the Property at 1001 West 19th Street, National City, CA 91950 for training purposes for Police and Fire personnel in a vacant structure. (Fire)
 13. National City Sales Tax Update Newsletter - First Quarter 2013. (Finance)
 14. Warrant Register #7 for the period of 8/7/13 through 8/13/13 in the amount of \$277,968.12. (Finance)
 15. Warrant Register #8 for the period of 8/14/13 through 8/20/13 in the amount of \$1,826,586.12. (Finance)
 16. Warrant Register #9 for the period of 8/21/13 through 8/27/13 in the amount of \$1,358,498.86. (Finance)
 17. Temporary Use Permit - 2013 State of the City Address sponsored by the City of National City on October 17, 2013 from 5pm to 8pm at Cornerstone Church located at 1914 Sweetwater Road. This is a City-sponsored event per Council Policy No. 804. (Neighborhood Services)

PUBLIC HEARINGS

ORDINANCES FOR INTRODUCTION

ORDINANCES FOR ADOPTION

18. An Ordinance of the City Council of the City of National City Amending Sections 18.30.360 and 18.41.020 (C) of Title 18 (Land Use Code) of the National City Municipal Code related to fast food restaurant locational requirements and drive-through business design guidelines. (Applicant The Focus Group) (Case File 2013-12 A) (Planning)

NON CONSENT RESOLUTIONS

NEW BUSINESS

19. Temporary Use Permit - St. Mary's Fall Festival hosted by St. Mary's Catholic Church on October 6, 2013 at the parish grounds located between E. 8th Street and 'E' Avenue from 7 a.m. to 6:30 p.m. with no waiver of fees.(Neighborhood Services)
20. Staff Update - City Council approved 2013-2018 Strategic Plan. (City Manager)

COMMUNITY DEVELOPMENT COMMISSION-HOUSING AUTHORITY

PUBLIC HEARINGS- HOUSING AUTHORITY

NON CONSENT RESOLUTIONS- HOUSING AUTHORITY

NEW BUSINESS- HOUSING AUTHORITY

STAFF REPORTS

21. Staff Report: Working outline and timeline for the development of the City of National City Three Year Operating Plan. (Administrative Services)

MAYOR AND CITY COUNCIL

22. Discussion on the formation of a Military Advisory Committee. (Councilmember Mona Rios)

CLOSED SESSION REPORT

ADJOURNMENT

Regular City Council/Community Development/Housing Authority of the City of National City Meeting - Tuesday - October 1, 2013 - 6:00 p.m. - Council Chambers - National City, California.

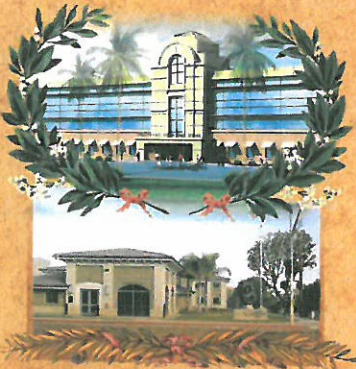
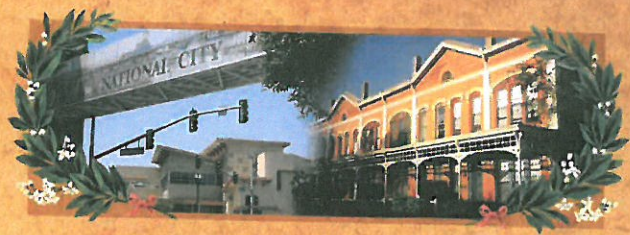

Proclamation

CALIFORNIA
NATIONAL CITY
1887
INCORPORATED

WHEREAS, September 17, 2013 marks the two hundred and twenty-sixth anniversary of the drafting of the Constitution of the United States of America by the Constitutional Convention; and

WHEREAS, it is fitting and proper to read, study, and preach the greatest document of human liberty and to protect the freedoms set forth in the Bill of Rights; and

WHEREAS, it is fitting and proper to officially recognize this magnificent document and the anniversary of its creation; and

WHEREAS, It is fitting and proper to officially recognize the patriotic celebrations which will commemorate the occasion; and

WHEREAS, public law 915 guarantees the Issuing of a proclamation each year by the President of the United States of America designating September 17th through September 23rd as Constitution Week.

NOW THEREFORE, BE IT PROCLAIMED, I, Ron Morrison as Mayor of the City of National City, by virtue of the authority vested in me by the City of National City, affix the official seal and together with the City Council, do hereby proclaim September 17, through September 23, 2013 as:

CONSTITUTION WEEK

I call upon all citizens of the City of National City to take a moment to study the Constitution, and reflect on the privilege of being an American with all the rights and responsibilities which that privilege involves.

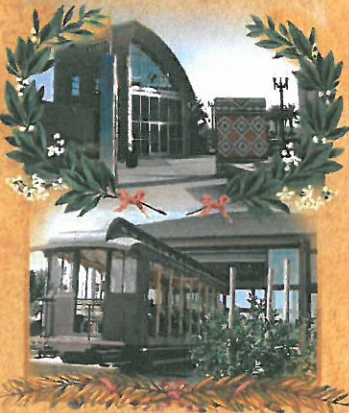

Ron Morrison
Mayor

Luis Natividad
Vice Mayor

Jerry Cano
Councilmember

Mona Rios
Councilmember

Alejandra Solis Solis
Councilmember



CITY OF NATIONAL CITY
M E M O R A N D U M

DATE: August 29, 2013
TO: Leslie Deese, City Manager
FROM: Stacey Stevenson, Director of Administrative Services
SUBJECT: EMPLOYEE OF THE QUARTER PROGRAM

The Employee Recognition Program communicates the City's appreciation for outstanding performance. In doing so, it recognizes employees who maintain high standards of personal conduct and make significant contributions to the workplace and community.

The employee to be recognized for the third quarter of calendar year 2013 is Rustico Aguilar – Custodian.

By copy of this memo, the employee is invited to attend the Council meeting on Tuesday, September 17, 2013 to be recognized for his achievement and service.

Attachment

cc: Rustico Aguilar
Joe Smith – Director of Public Works
Josie Flores-Clark – Executive Assistant
Human Resources – Office File



**Performance Recognition Award
Nomination Form**

I nominate Rustico Aguilar for the Performance Recognition Award for the following reasons:

Please state reason why your nominee should receive an award, (i.e., examples of service beyond requirements of position, exemplary service to the public, outstanding job performance, etc). Do not to exceed 150 total words. Please be as specific as possible when giving your examples.

I am very proud to nominate Mr. Rustico "Rusty" Aguilar for the Employee of the Quarter 2013.

Rusty first joined our organization in August of 2002. His skills and dedication to the City have proven invaluable for over 11 years. And for each day of those 11 years his enthusiasm for the job is still the same as his first day he joined our City.

Rusty is always willing to take on any challenge at any time and sometime with just a moments' notice but always giving 100% while dealing with the numerous problems that occur each and every day in the maintenance of the City facilities.

He is truly a team player.

Rusty is a pleasure to work with and a person anyone can go to for assistance. Rusty is an exceptional employee and an asset, not only to Public Works but to our entire organization. The City is fortunate to have Rusty as an employee.

FORWARD COMPLETED NOMINATION TO:

National City Performance Recognition Program
Human Resources Department

Nominated by: Joe Smith, Director of Public Works

Signature:  Date: August 28, 2013



City of National City
MEMORANDUM

DATE: August 20, 2013

TO: Lavonne Watts, Executive Assistant IV (City Manager's Office)
Josie Flores-Clark, Executive Assistant III (Mayor/Council Office)

FROM: Lilia Muñoz, Human Resources Analyst *LM*

SUBJECT: ANNIVERSARY RECOGNITION

The following City employee will complete his 30 years of service with the City of National City on September 1, 2013:

NAME : Miguel Diaz
POSITION : Park Superintendent
HIRED : September 1, 1983

As part of the Employee Recognition Program, the employee wishes to have the opportunity to receive a City Council Recognition at the Council Meeting of Tuesday, September 17, 2013.

If this is acceptable, please make the necessary arrangements and send confirmation of the schedule to the employee, department and our office. The recognition letter, gift certificate selection and anniversary pin will be sent prior to the presentation.

Thank you.

cc: Miguel Diaz, Park Superintendent
Joe Smith, Director of Public Works

ITEM #
9/17/13

UNIFIED PORT OF SAN DIEGO UPDATE
PORT COMMISSIONER
ROBERT (DUKIE) VALDERRAMA

**CITY OF NATIONAL CITY, CALIFORNIA
COUNCIL AGENDA STATEMENT**

MEETING DATE: September 17, 2013

AGENDA ITEM NO. _____

ITEM TITLE:

Interviews and Appointments: Various Boards / Commissions / Committees. (City Clerk)

PREPARED BY: Michael R. Dalla

DEPARTMENT: City Clerk

PHONE: 619-336-4226

APPROVED BY: _____

EXPLANATION:

New Applicant:

- | | | |
|-------------------|------|-------------------------|
| • Rodolfo Robledo | CPRC | Needs to be Interviewed |
|-------------------|------|-------------------------|

Incumbents Requesting Re-appointment:

- | | | |
|-------------------|--------------------------|-----------------------|
| • William Sendt | Civil Service Commission | Invited to be Present |
| • Memo Cavada | Public Art Committee | Invited to be Present |
| • William Virchis | Public Art Committee | Invited to be Present |

Vacancies

There are or will be vacancies on the following:

- | | |
|----------------------------|--------------|
| • CPRC | 2 (resident) |
| • Library Board | 1 |
| • Traffic Safety Committee | 2 |

FINANCIAL STATEMENT:

APPROVED: _____ Finance

ACCOUNT NO.

APPROVED: _____

ENVIRONMENTAL REVIEW:

ORDINANCE: INTRODUCTION:

FINAL ADOPTION:

STAFF RECOMMENDATION:

Conduct interviews (to appear on October 1, 2013 Agenda for action).

BOARD / COMMISSION RECOMMENDATION:

ATTACHMENTS:

1. Application

**CITY OF NATIONAL CITY
APPLICATION FOR APPOINTMENT
TO CITY BOARDS, COMMISSIONS, AND COMMITTEES**

<input type="checkbox"/> Civil Service Commission	<input type="checkbox"/> Planning Commission
<input checked="" type="checkbox"/> Community & Police Relations Commission* (CPRC)	<input type="checkbox"/> Public Art Committee*
<input type="checkbox"/> Library Board of Trustees	<input type="checkbox"/> Traffic Safety Committee
<input type="checkbox"/> Parks, Recreation & Senior Citizens Advisory Board	

RECEIVED
CITY CLERK

Note: Applicants must be residents of the City of National City except for those marked by an *

Applicants for the Community and Police Relations Commission must pass a background check prior to appointment.

Name: RODOLFO (RUDY) ROBLEDO

Home Address: 3131 F AVE Tel. No.: 619-477-1032

Business Affiliation: _____ Title: _____

Business Address: _____ Tel. No.: _____

Length of Residence in National City: 25 yrs San Diego County: 54 yrs California: 54 yrs

Educational Background: COMPLETED 4 yr APPRENTICESHIP
TOOL MAKER SDC (MESA COLLEGE) GEN. DYN.

Occupational Experience: 24 yrs IN AEROSPACE CURRENTLY
DEVELOPMENT TECH AT UTC AEROSPACE

Professional or Technical Organization Memberships: SOCIETY OF MFG. ENG.

Civic or Community Experience, Membership, or Previous Public Service Appointments:

PROJECT AREA COMMITTEE

Experience or Special Knowledge Pertaining to Area of Interest:

I CARE!

Have you ever been convicted of a felony crime? No: Yes: ___ misdemeanor crime? No: ___ Yes: ___
If any convictions were expunged disclosure is not required. Convictions are not necessarily disqualifying.

Please feel free to provide an explanation or information regarding yes answers to the above two questions.

Date: 6/3/13

Signature: R. Robledo

Please feel free to provide additional information or letters of endorsement.

Please return completed form to:
Office of the City Clerk
1243 National City Blvd, National City, CA 91950

Thank you for your interest in serving the City of National City.

* Residency requirements may not apply
This documents is filed as a public document

Supplemental Application:
National City Community and Police Relations Commission

The National City Community and Police Relations Commission serves as an independent, unbiased and impartial office that is readily available to the public. It is an organization for the improvement of police and community relations and the facilitation of disputes whenever possible. It provides a forum for citizens to voice their concerns, comment about police conduct, practices and policies and improves communication between citizens and the National City Police Department

The National City Community and Police Relations Commission is empowered to receive and review complaints regarding National City Police Department Personnel for alleged misconduct, and to recommend appropriate changes of Police Department policies and procedures toward the goals of safeguarding the rights of persons and promoting higher standards of competency, efficiency and justice in the provision of community policing services.

Applicants must be completely forthright and truthful during the application process. Applicants may be disqualified in the background process as a result of dishonesty and/or purposely omitting information regarding one's criminal history. Given the complexity of this Commission and its duties, it is necessary to pass a criminal background check prior to appointment by City Council and/or swearing in as Commissioner. The Human Resources department will contact you to schedule the criminal background process when, and if appropriate. It is important to note that you fill out this application completely and honestly to the best of your abilities. Failure to disclose your criminal history may result in disqualification. If a conviction has been expunged disclosure is not required.

Have you ever been convicted of a felony crime: No: Yes:

Have you been convicted of a misdemeanor: No: Yes:

If any convictions were expunged disclosure is not required.

Please feel free to provide an explanation or information regarding yes answers to the above two questions.

DUI 22yrs ago

There may be circumstances that could disqualify an applicant from the background process beyond the listed crimes below. Each incident is evaluated in terms of the circumstances and facts surrounding its occurrence and its degree of relevance to the position.

Disqualifying criteria for Community and Police Relations Commissioner:

** See attached table

Disqualifying Criteria for National City Community and Police Relations Commission

<u>Felonies</u>		<u>Lifetime</u>	<u>20 years</u>	<u>15 years</u>	<u>10 years</u>	<u>5 years</u>
Crimes against Persons	*including but not limited to					
	Assault & Battery	x				
	Domestic Violence	x				
	Elder/Child Abuse	x				
	Manslaughter			x		
	Murder	x				
	Sexual Acts w/ Minor	x				
	Rape	x				
Crimes against Property	*including but not limited to					
	Arson		x			
	Burglary			x		
	Embezzlement			x		
	Extortion			x		
	Fraud			x		
	Forgery & Counterfeiting			x		
	Possession of stolen property			x		
	Theft			x		
Crimes involving Drugs	*including but not limited to					
	Illegal Drug Use			x		
	Possession or Sales			x		
	Production of Drugs			x		
Crimes against Public Justice						
	Bribery & Corruption			x		
	Impersonating a Peace Officer			x		
<u>Misdemeanors</u>		<u>Lifetime</u>	<u>20 years</u>	<u>15 years</u>	<u>10 years</u>	<u>5 years</u>
Crimes of Moral Turpitude	*including but not limited to					
	Burglary				x	
	Embezzlement				x	
	Forgery				x	
	Fraud				x	
	Possession of stolen property				x	
	Theft				x	
Crimes involving Drugs or Alcohol	*including but not limited to	<u>Lifetime</u>	<u>20 years</u>	<u>15 years</u>	<u>10 years</u>	<u>5 years</u>
	Disorderly Conduct					x
	Under the Influence					x
	Unlawful Possession					x
Crimes against Persons	*including but not limited to					
	Assault & Battery					x
	Manslaughter				x	

Item # _____
09/17/13

**APPROVAL OF THE MINUTES OF THE ADJOURNED
REGULAR MEETINGS OF THE CITY COUNCIL AND
COMMUNITY DEVELOPMENT COMMISSION – HOUSING
AUTHORITY OF THE CITY OF NATIONAL CITY OF
JUNE 11, 2013 AND AUGUST 6, 2013 AND MINUTES OF
THE SPECIAL MEETING OF THE CITY COUNCIL AND
COMMUNITY DEVELOPMENT COMMISSION – HOUSING
AUTHORITY OF THE CITY OF NATIONAL CITY OF
AUGUST 6, 2013.
(City Clerk)**

**MINUTES OF THE ADJOURNED REGULAR MEETING OF THE
CITY COUNCIL AND COMMUNITY DEVELOPMENT COMMISSION
– HOUSING AUTHORITY OF THE CITY OF NATIONAL CITY**

CITY COUNCIL POLICY MANUAL WORKSHOP

June 11, 2013

The Adjourned Regular Meeting of the City Council and Community Development Commission – Housing Authority of the City of National City was called to order at 6:03 p.m. by Mayor / Chairman Ron Morrison.

ROLL CALL

Council / Board members present: Cano, Morrison, Natividad, Rios, Sotelo-Solis.
Administrative Officials present: Dalla, Deese, Duong, Manganiello, Raulston, Silva, Smith, Williams.

PLEDGE OF ALLEGIANCE TO THE FLAG BY MAYOR RON MORRISON

PUBLIC ORAL COMMUNICATION

None

CITY COUNCIL POLICY MANUAL (CHAPTER 100 POLICIES)

1. City Council Review and Approval of Proposed Updates to the City Council Policy Manual (Chapter 100 Policies). (City Manager and City Attorney)

Each City Council policy and corresponding Staff recommendation were taken up for consideration in numeric order.

Policy No. 101: City Council Policy Manual

RECOMMENDATION: Change Title from “Annual Policy Review” to “City Council Policy Manual”, add ‘Background’ section and elaborate on various areas of policy.

ACTION: Motion by Sotelo-Solis, seconded by Natividad, to approve as proposed by staff and that newly elected Council Members should receive an orientation within 60 days of taking office. Carried by unanimous vote.

CITY COUNCIL POLICY MANUAL (CHAPTER 100 POLICIES) (cont.)

Policy No. 102: City Council Meeting Times

RECOMMENDATION: Add location/time for regular meetings, details regarding holidays, statement regarding Brown Act and incorporate language from Policy No. 103 "Special Council Meetings".

ACTION: Motion by Natividad, seconded by Sotelo-Solis, to approve staff recommendation. Carried by unanimous vote.

Policy No. 103: Special Council Meetings

RECOMMENDATION: Delete Policy No. 103 and merge with Policy No. 102.

ACTION: Motion by Rios, seconded by Natividad, to approve staff recommendation. Carried by unanimous vote.

Policy No. 104: Conduct of City Council Meetings

RECOMMENDATION: Add reference to the 'Brown Act'; switch from 'Robert's Rules of Order' to 'Rosenberg's Rules of Order' and update 'Related Policy References'.

ACTION: Motion by Rios, seconded by Natividad, to approve as proposed by staff and the rules change apply to all City entities. Carried by unanimous vote.

Policy No. 105: Off Agenda Items

RECOMMENDATION: Add information regarding Brown Act compliance; define criteria for adding off-agenda and urgency items and add language regarding future agenda items, non-agenda public comments, and 'request-to-speak' forms.

ACTION: Motion by Natividad, seconded by Sotelo-Solis, to approve staff recommendation. Carried by unanimous vote.

Policy No. 106: Preparation of City Council Meeting Minutes

RECOMMENDATION: Change Title from "Preparation of Council Minutes" to "Preparation of City Council Meeting Minutes", delete "tape recordings" and add "video recordings", include subsidiary functions besides just City Council, add timeline for posting minutes and videos and add length of time videos and minutes will be maintained on the website.

ACTION: Motion by Natividad, seconded by Cano, to approve as proposed by staff. Carried by unanimous vote.

CITY COUNCIL POLICY MANUAL (CHAPTER 100 POLICIES) (cont.)

Policy No. 107: Appointments to Boards and Commissions

RECOMMENDATION: Add list of Boards, Commissions and Committees to which the policy applies to Section called "Purpose", add sections regarding unscheduled vacancies, preparing the appointment list, applicant presentations and related references, and amend lists of Mayor and City Council appointing authority.

ACTION: Motion by Natividad, seconded by Cano, to approve staff recommendation. Carried by unanimous vote.

Policy No. 108: City Manager as Chief Administrative Officer

RECOMMENDATION: Add background section, reference the Municipal Code Section 2.01.030 dealing with City Manager authority and clarify language regarding City Council direction to employees.

ACTION: Motion by Sotelo-Solis, seconded by Natividad, to approve staff recommendation. Carried by unanimous vote.

Policy No. 109: Travel and Training Reimbursement

RECOMMENDATION: Add language about 'Purchasing Review Committee' and approvals, following existing Purchasing procedures and Policy References; delete forms and referenced availability from Finance; elaborate on procedures for trouble with city-owned vehicles; require receipts for all items to be reimbursed; delete majority of language regarding Credit Cards and referred, instead, to Administrative Policy 3.14 and delete language allowing reimbursement at IRS rates without meal receipts.

ACTION: Motion by Cano, seconded by Natividad, to approve staff recommendation. Carried by unanimous vote.

Policy No. 110: Display of Flags

RECOMMENDATION: Identify 'permanent' vs. 'ceremonial' flags, delete reference to Military Affairs Advisory Committee and add California and United States Flag Code to "Related Policy References".

ACTION: Motion by Rios, seconded by Natividad, to approve staff recommendation. Carried by unanimous vote.

CITY COUNCIL POLICY MANUAL (CHAPTER 100 POLICIES) (cont.)

Policy No. 111: Utilization of City Vehicles in Non-Safety Related Capacities

RECOMMENDATION: Change 'Non-Work Related' to 'Non-Safety Related' (in title and text) since staff will occasionally be working (on duty/paid status) when operating vehicles, authorize City Manager to approve use requests and provide updates to Council and delete administrative details in the Council Policy since a new Administrative Policy will be drafted.

ACTION: Motion by Natividad, seconded by Cano, to approve staff recommendation and include language dealing with static vehicles or displays. Carried by unanimous vote.

Policy No. 112: Document Reproduction

RECOMMENDATION: Delete the policy and replace with a new policy regarding Public Records Act / Protocol.

ACTION: Motion by Natividad, seconded by Sotelo-Solis, to approve staff recommendation. Carried by unanimous vote.

Policy No. 113: Unauthorized Disclosure of Information Revealed in Closed Sessions

RECOMMENDATION: Revise section on 'Related Policy References', add Item No. 4 regarding Government Code Section 54963 and revise legal brief dated 02-29-96 due to changes in Government Code Section 54963.

ACTION: Motion by Sotelo-Solis, seconded by Natividad, to approve as proposed by staff. Carried by unanimous vote.

Policy No. 114: Grant Activities

RECOMMENDATION: Change the name of the form from "Request to Apply for Federal, State, and Local Government Grants or Private Funds" to "Grant Application" form; reference the Grant Coordinator; concur that City Manager can delegate Council updates and Letters of Authorization to a designee; require grants that require matching funds in an amount which exceeds the City Manager's signature authority to require City Council approval prior to acceptance and update 'Related Policy References'.

ACTION: Motion by Natividad, seconded by Cano, to approve staff recommendation. Carried by unanimous vote.

CITY COUNCIL POLICY MANUAL (CHAPTER 100 POLICIES) (cont.)

Policy No. 115: Donation of Surplus City Property and Police Department Unclaimed Property

RECOMMENDATION: Delete the report from the Purchasing Agent dated 05-06-03 and incorporate applicable information into the policy; expand the policy to include donations to Sister-Cities and other municipal agencies; remove 'Request for Donation' form; expand policy to address issues of liability and gifts of public funds; add 'Procedures' and expand 'Related Policy References' to include Municipal Code sections.

ACTION: Motion by Natividad, seconded by Sotelo-Solis, to approve staff recommendation and add language specifying eligible entities to be 'local public government agencies and Sister Cities'. Carried by unanimous vote.

Policy No. 116: Procedure for Disclosure of Ex Parte Contacts

RECOMMENDATION: Expand definition of 'information' received to include oral, written or other.

ACTION: Motion by Sotelo-Solis, seconded by Natividad, to approve staff recommendation. Carried by unanimous vote.

Policy No. 117: Distribution and Reporting of Tickets and Passes Distributed to or at the Behest of a City Official.

RECOMMENDATION: Change the title, add 'Background' section and reference to Successor Agency to the Community Development Commission and re-number sections.

ACTION: Motion by Natividad, seconded by Cano, to approve staff recommendation. Carried by unanimous vote.

2. Staff reported on a question raised at a previous City Council meeting regarding establishment of a regular meeting between the Mayor and Vice Mayor. Staff indicated that such a meeting would be subject to all the provisions of the Brown Act and as such require public notice, a posted agenda and public participation.

ACTION: Motion by Sotelo-Solis, to move forward asking staff to bring back a draft policy on such a meeting. Extensive discussion followed.

Motion by Natividad, seconded by Sotelo-Solis, to end discussion and call the question. Motion carried by the following vote, to-wit; Ayes: Cano, Natividad, Rios, Sotelo-Solis, Nays: Morrison.

It was reported that the original motion had not received a 'second'. The motion was re-stated by Sotelo-Solis, seconded by Rios, to move forward asking staff to bring back a draft policy on such a meeting. Motion carried by the following vote, to-wit; Ayes: Natividad, Rios, Sotelo-Solis. Nays: Morrison, Cano.

CITY COUNCIL POLICY MANUAL (CHAPTER 100 POLICIES) (cont.)

3. City Manager Deese inquired if the City Council had a preference on how they would like to proceed in considering the remainder of the City Council Policy updates.

ACTION: Motion by Natividad, to direct the City Manager to look at the remainder of the policies and determine which ones can be considered as part of a regular Council agenda and which ones will require a workshop. Motion died for lack of a second.

Motion by Sotelo-Solis, seconded by Rios, to have the City Manager bring back dates for workshops. Motion failed by the following vote, to-wit, Ayes: Sotelo-Solis, Rios. Nays: Cano, Natividad, Morrison.

Motion by Natividad, seconded by Cano, to re-introduce previous motion to have the City Manager go through the policies and to try to insert consideration of policy updates into the Regular Agenda when she considers it practical to do so. Motion ruled out of order.

Motion by Cano, seconded by Natividad, to adopt the previous motion made by Vice Mayor Natividad. Motion carried by the following vote, to-wit: Ayes: Cano, Morrison, Natividad, Rios. Nays: Sotelo-Solis. Absent: None. Abstain: None.

ADJOURNMENT

Motion by Sotelo-Solis, seconded by Rios, to adjourn the meeting to the next Regular Meeting of the City Council and Community Development Commission – Housing Authority of the City of National City to be held Tuesday, June 18, 2013 at 6:00 p.m. at the Council Chambers, National City, California. Carried by unanimous vote.

Regular Meeting of the Successor Agency to the Community Development Commission as the National City Redevelopment Agency to be held Tuesday, April 16, 2013 at 6:00 p.m. at the Council Chambers, National City, California.

The meeting closed at 8:35 p.m.

City Clerk

The foregoing minutes were approved at the Regular Meeting of September 17, 2013.

Mayor

DRAFT

DRAFT DRAFT DRAFT

**MINUTES OF THE ADJOURNED REGULAR MEETING OF THE
CITY COUNCIL AND COMMUNITY DEVELOPMENT COMMISSION
– HOUSING AUTHORITY OF THE CITY OF NATIONAL CITY**

August 6, 2013

The Adjourned Regular Meeting of the City Council and Community Development Commission – Housing Authority of the City of National City was called to order at 5:02 p.m. by Mayor / Chairman Ron Morrison.

ROLL CALL

Council / Board members present: Cano, Morrison, Natividad, Rios, Sotelo-Solis.
Administrative Officials present: Dalla, Deese, Manganiello, Parra, Roberts, Rodriguez, Silva, Smith, Stevenson, Vergara, Williams.

PLEDGE OF ALLEGIANCE TO THE FLAG BY MAYOR RON MORRISON

PUBLIC ORAL COMMUNICATIONS

Estela Delos Rios and Jose Presciado appeared on behalf of CSA San Diego to thank the City for allowing them to partner with the City to provide Fair Housing Services.

Stewart Pane, Chula Vista, spoke against Alliant University locating in the National City Adult School facility.

Frances Brinkmen, Chula Vista, spoke against Alliant University.

Kevin O'Nely, Chula Vista, spoke against Alliant University.

Maty Aolato, Chula Vista, spoke against Alliant University.

Kathleen Cheers San Diego, spoke against Alliant University.

Christian Deguire, Chula Vista, requested a \$200 donation for his Eagle Scout project at the Stein Farm.

CITY COUNCIL

PRESENTATIONS

COUNCIL MEETING PRESENTATIONS 2013 (102-10-8)

1. Recognition of Community Emergency Response Team (CERT) Academy #5 Graduates. (Fire)

Vice Mayor Natividad left the Council Chamber at 5:31 pm

COUNCIL MEETING PRESENTATIONS 2013 (102-10-8)

2. Presentation of National City Fire Department's new Strike Team Leader – Battalion Chief Sergio Mora. (Fire)

CONSENT CALENDAR

ADOPTION OF CONSENT CALENDAR. Item No. 3 (Minutes), Item Nos. 4 through 9 (Resolution Nos. 2013-111 through 2013-116), Item Nos. 10 through 14 (Warrant Registers), Item No. 15 (Resolution No. 2013-117). Motion by Rios, seconded by Sotelo-Solis, to approve the Consent Calendar. Carried by the following vote, to-wit: Ayes: Cano, Morrison, Rios, Sotelo-Solis. Nays: None. Absent: Natividad. Abstain: None.

APPROVAL OF MINUTES

3. **SUBJECT:** Approval of the Minutes of the Regular Meetings of the City Council & Community Development Commission – Housing Authority of the City of National City of December 4, 2012, June 4, 2013 and May 14, 2013. (City Clerk)
ACTION: Approved. See above.

PARKING & TRAFFIC CONTROL ADMIN 2013 (801-2-34)

4. Resolution No. 2013-111. RESOLUTION OF THE CITY COUNCIL OF THE CITY OF NATIONAL CITY AUTHORIZING THE ISSUANCE OF A SPECIAL DRIVEWAY PERMIT FOR THE PROPERTY AT 1339 ROOSEVELT AVENUE FOR THE INSTALLATION OF A DRIVEWAY APRON WHERE CITY STANDARDS CANNOT OTHERWISE BE MET, TO ALLOW FOR MORE EFFICIENT TRUCK LOADING/UNLOADING. (Engineering)
ACTION: Adopted. See above.

CONSENT CALENDAR (cont.)

CONTRACT (C2008-53)

5. Resolution No. 2013-112. RESOLUTION OF THE CITY COUNCIL OF THE CITY OF NATIONAL CITY APPROVING A CONTRACT AGREEMENT BETWEEN THE CITY OF NATIONAL CITY AND ESGIL CORPORATION TO PROVIDE ON-CALL PLAN REVIEWS, PERMIT PROCESSING, CONSTRUCTION INSPECTIONS, CODE ENFORCEMENT SERVICES AND RELATED SERVICES FOR VARIOUS CITY DEPARTMENTS INCLUDING BUT NOT LIMITED TO BUILDING, FIRE, AND ENGINEERING IN THE NOT-TO-EXCEED AMOUNT OF \$400,000 PER YEAR FOR A PERIOD OF THREE YEARS, AND AUTHORIZING THE MAYOR TO EXECUTE THE AGREEMENT. (Funded by fees collected, developer deposits and various Capital Improvement Project funds and other funds as needed). (Building)

ACTION: Adopted. See above.

BUDGET FY 2013-2014 (206-1-29)

6. Resolution No. 2013-113. RESOLUTION OF THE CITY COUNCIL OF THE CITY OF NATIONAL CITY TO ACCEPT AND APPROVE THE PROPOSED FY13/14 (JULY 2013-JUNE 2014) REGIONAL COOPERATIVE CARE PROGRAM (RCCP) BUDGET PROVIDED BY THE JOINT EXERCISE OF POWERS AGREEMENT THAT CONSOLIDATES AND SHARES ADMINISTRATIVE, TRAINING AND OVERSIGHT SERVICES RELATED TO THE PROVISION OF PRE-HOSPITAL EMERGENCY MEDICAL SERVICES, AT NO ADDITIONAL COST TO THE GENERAL FUND. (Fire)

ACTION: Adopted. See above.

GRANT / PUBLIC SAFETY (206-4-27)

7. Resolution No. 2013-114. RESOLUTION OF THE CITY COUNCIL OF THE CITY OF NATIONAL CITY AUTHORIZING THE ACCEPTANCE OF A GRANT AWARD OF \$66,450.00 FROM THE CALIFORNIA OFFICE OF TRAFFIC SAFETY (OTS), SOBRIETY CHECKPOINT GRANT PROGRAM THROUGH THE UNIVERSITY OF CALIFORNIA BERKELEY SAFE TRANSPORTATION RESEARCH AND EDUCATION CENTER (SAFETREC) FOR DUI CHECKPOINTS AND CHECKPOINT SUPPLIES. (Police)

ACTION: Adopted. See above.

CONSENT CALENDAR (cont.)

GRANT / PUBLIC SAFETY (206-4-27)

8. Resolution No. 2013-115. RESOLUTION OF THE CITY COUNCIL OF THE CITY OF NATIONAL CITY AUTHORIZING THE ACCEPTANCE OF A GRANT AWARD OF \$128,788.00 FROM THE CALIFORNIA OFFICE OF TRAFFIC SAFETY (OTS) FOR THE SELECTIVE TRAFFIC ENFORCEMENT PROGRAM (STEP) GRANT PROJECT 2014 TO CONDUCT DUI AND TRAFFIC RELATED ENFORCEMENT OPERATIONS FOR THE POLICE DEPARTMENT. (Police)
ACTION: Adopted. See above.

GRANT / PUBLIC SAFETY (206-4-27)

9. Resolution No. 2013-116. RESOLUTION OF THE CITY COUNCIL OF THE CITY OF NATIONAL CITY AUTHORIZING THE ACCEPTANCE, AND THE 30-DAY REVIEW AND COMMENT OF THE NATIONAL CITY POLICE DEPARTMENT'S GRANT APPLICATION IN THE AMOUNT OF \$31,110 FROM THE 2013 EDWARD BYRNE MEMORIAL JUSTICE ASSISTANCE GRANT (JAG) PROGRAM TO PURCHASE A TACTICAL ROBOT AND MEDICAL/FIRST AID KITS. (Police)
ACTION: Adopted. See above.

WARRANT REGISTER JULY 2012 – JUNE 2013 (202-1-27)

10. Warrant Register #50 for the period of 06/05/13 through 06/11/13 in the amount of \$1,408,247.72. (Finance)
ACTION: Ratified. See above.

WARRANT REGISTER JULY 2012 – JUNE 2013 (202-1-27)

11. Warrant Register #51 for the period of 06/12/13 through 06/18/13 in the amount of \$373,000.95. (Finance)
ACTION: Ratified. See above.

WARRANT REGISTER JULY 2012 – JUNE 2013 (202-1-27)

12. Warrant Register #52 for the period of 06/19/13 through 06/25/13 in the amount of \$1,563,729.50. (Finance)
ACTION: Ratified. See above.

WARRANT REGISTER JULY 2012 – JUNE 2013 (202-1-27)

WARRANT REGISTER JULY 2013 – JUNE 2014 (202-1-28)

13. Warrant Register #1 for the period of 06/26/13 through 07/02/13 in the amount of \$1,132,073.35. (Finance)
ACTION: Ratified. See above.

CONSENT CALENDAR (cont.)

WARRANT REGISTER JULY 2013 – JUNE 2014 (202-1-28)

14. Warrant Register #2 for the period of 07/03/13 through 07/09/13 in the amount of \$2,427,992.71. (Finance)
ACTION: Ratified. See above.

PROPERTY TAX RATE BONDED INDEBTEDNESS ADMIN (205-2-2)

15. Resolution No. 2013-117. RESOLUTION OF THE CITY COUNCIL OF THE CITY OF NATIONAL CITY AUTHORIZING REDUCTION THE PROPERTY TAX RATE FOR BONDED INDEBTEDNESS FOR FISCAL YEAR 2014 FROM 1.32 CENTS PER \$100 OF ASSESSED VALUATION TO 1.19 CENTS. (Finance)
ACTION: Adopted. See above.

Vice Mayor Natividad returned to the Council Chamber at 5:33 pm.

PUBLIC HEARING

SEWER CAPACITY / FEES ADMIN (906-1-4)

16. A Public Hearing to consider the report required by California Health and Safety Code Section 5473, Et Seq. pertaining to collection of sewer charges on the tax roll, directing the City Clerk to file said report with the San Diego County Auditor, and directing the Public Works Director to certify with the San Diego County Auditor the "Sewer Service Charge Fund." Sewer service fees will not increase for FY 13-14. (Public Works)
RECOMMENDATION: Hold the Public Hearing.
TESTIMONY: None.
ACTION: Motion by Rios, seconded by Sotelo-Solis, to close the Public Hearing. Carried by unanimous vote.

ORDINANCE FOR INTRODUCTION

MUNICIPAL CODE 2013 (506-2-28)

17. AN ORDINANCE OF THE CITY COUNCIL OF THE CITY OF NATIONAL CITY AMENDING CHAPTER 1.08 OF THE NATIONAL CITY MUNICIPAL CODE PERTAINING TO OFFICIAL CITY SEALS, LOGOS, INSIGNIAS, BADGES, AND NAMES. (City Attorney)

NON CONSENT RESOLUTIONS

SEWER CAPACITY / FEES ADMIN (906-1-4)

18. Resolution No. 2013-118. RESOLUTION ADOPTING THE REPORT REQUIRED BY CALIFORNIA HEALTH AND SAFETY CODE SECTION 5473, ET SEQ. PERTAINING TO COLLECTION OF SEWER CHARGES ON THE TAX ROLL, DIRECTING THE CITY CLERK TO FILE SAID REPORT WITH THE SAN DIEGO COUNTY AUDITOR, AND DIRECTING THE PUBLIC WORKS DIRECTOR TO CERTIFY WITH THE SAN DIEGO COUNTY AUDITOR THE "SEWER SERVICE CHARGE FUND". SEWER SERVICE FEES WILL NOT INCREASE FOR FY 13-14. (Public Works)

RECOMMENDATION: Adopt the Resolution.

TESTIMONY: None.

ACTION: Motion by Sotelo-Solis, seconded by Rios, to adopt the Resolution. Carried by unanimous vote.

CONTRACT (C2010-28)

19. Resolution No. 2013-119. RESOLUTION OF THE CITY COUNCIL OF THE CITY OF NATIONAL CITY 1) APPROVING AMENDMENT NO. 2 TO THE MEMORANDUM OF UNDERSTANDING BETWEEN THE SAN DIEGO UNIFIED PORT DISTRICT AND THE CITY OF NATIONAL CITY WHEREIN THE DISTRICT REALLOCATED FUNDS FROM THE PORT PARK PROJECT TO THE AQUATIC CENTER, 2) AUTHORIZE THE MAYOR TO EXECUTE AMENDMENT NO. 2, AND 3) AUTHORIZE THE APPROPRIATION OF \$3,080,000. (Funded by General Fund to be reimbursed by the San Diego Unified Port District) (Engineering)

RECOMMENDATION: Adopt the Resolution.

TESTIMONY: None.

ACTION: Motion by Rios, seconded by Sotelo-Solis, to adopt the Resolution. Carried by unanimous vote.

CONTRACT (C2010-28)

20. Resolution No. 2013-120. RESOLUTION OF THE CITY COUNCIL OF THE CITY OF NATIONAL CITY APPROVING AMENDMENT NO. 2 TO THE AQUATIC CENTER LEASE AGREEMENT BETWEEN THE SAN DIEGO UNIFIED PORT DISTRICT AND THE CITY OF NATIONAL CITY. (Engineering)

RECOMMENDATION: Adopt the Resolution.

TESTIMONY: None.

ACTION: Motion by Rios, seconded by Cano, to adopt the Resolution. Carried by unanimous vote.

NEW BUSINESS

CONDITIONAL USE PERMITS (403-28-1)

21. Notice of Decision – Planning Commission approval of a Conditional Use Permit and Planned Development Permit for a new drive-in and drive-through Sonic restaurant within an existing shopping center, with an exception for less than required parking, located at 3007 Highland Avenue. (Applicant: SPG Management, LLC.) (Case File 2013-14 CUP, PD) (Planning Division)

RECOMMENDATION: Staff concurs with the decision of the Planning Commission and recommends that the Notice of Decision be filed.

TESTIMONY: None.

ACTION: Motion by Sotelo-Solis, seconded by Rios, to approve staff recommendation. Carried by unanimous vote.

MARTIN LUTHER KING JR. COMMUNITY CENTER (1101-5-1)

22. Request to use Martin Luther King Jr. Community Center (North Room) by National School District for a professional development session for approximately 100 teachers on Tuesday, August 13, 2013, from 7:00 am to 4:00 pm. Applicant is not requesting a waiver of fees. (Public Works)

RECOMMENDATION: The requested use is in accordance with Council Policy 803. Staff recommends approving the Facility Use Application and payment of all fees.

TESTIMONY: None.

ACTION: Motion by Rios, seconded by Sotelo-Solis, to approve staff recommendation. Carried by unanimous vote.

TEMPORARY USE PERMIT (203-1-29)

23. TEMPORARY USE PERMIT – Pumpkin Station hosted by Pinery Christmas Trees, Inc. at Westfield Plaza Bonita Mall from September 27, 2013 thru October 31, 2013 with no waiver of fees. (Neighborhood Service)

RECOMMENDATION: Approve the application for a Temporary Use Permit subject to compliance with all conditions of approval with no waiver of fees.

TESTIMONY: None.

ACTION: Motion by Sotelo-Solis, seconded by Rios, to approve staff recommendation. Carried by unanimous vote.

NEW BUSINESS (cont.)

BOARDS & COMMISSIONS ADMIN (101-1-1)

24. Request City Council approve the appointments of City Manager and Executive Director as Member and Alternate to the San Diego Regional Military Working Group facilitated by the San Diego Association of Governments (SANDAG). (City Manager)

RECOMMENDATION: Appoint City Manager, Leslie Deese and Executive Director, Brad Raulston to participate as members of the San Diego Regional Military Working Group facilitated by San Diego Association of Governments (SANDAG).

TESTIMONY: None.

ACTION: Motion by Rios, seconded by Cano, to approve staff recommendation. Carried by unanimous vote.

**COMMUNITY DEVELOPMENT COMMISSION –
HOUSING AUTHORITY OF THE CITY OF NATIONAL CITY**

NO AGENDA ITEMS

STAFF REPORTS - None

MAYOR AND CITY COUNCIL

Member Sotelo-Solis acknowledged another successful Auto Heritage event at Kimball Park last weekend and reported that she will be making a presentation on her recent trip to Israel hosted by the Jewish Community Relations Council.

Member Rios acknowledge former Library Board Member Brian Clapper and re-stated her hope that the City can find a way to recognize the efforts and service of our volunteers.

Mayor Morrison reported that the City's National Night Out event was taking place at Las Palmas Park and encouraged everyone to participate immediately after the meeting adjourns.

CLOSED SESSION REPORT

City Attorney Claudia Silva stated there was nothing to report from the Closed Sessions for the City Council / Community Development Commission – Housing Authority held at 4:00 pm. (See attached Exhibit 'L')

ADJOURNMENT

Motion by Sotelo-Solis, seconded by Rios, to adjourn the meeting to the next Regular Meeting of the City Council and Community Development Commission – Housing Authority of the City of National City to be held Tuesday, August 20, 2013 at 6:00 p.m. at the Council Chambers, National City, California. Carried by unanimous vote.

The meeting closed at 5:48 p.m.

City Clerk

The foregoing minutes were approved at the Regular Meeting of September 17, 2013.

Mayor

EXHIBIT 'L'



AGENDA OF A SPECIAL MEETING

CITY COUNCIL OF THE CITY OF NATIONAL CITY
AND
COMMUNITY DEVELOPMENT COMMISSION – HOUSING AUTHORITY

Main Conference Room
Civic Center
1243 National City Boulevard
National City, California

Special Meeting – Tuesday, August 6, 2013 – 4:00 p.m.

ROLL CALL

OPEN SESSION

CITY COUNCIL

1. Real Property Transaction – 1726 Wilson Avenue, National City
APN: 559-086-03-00
Agency Negotiator: Brad Raulston
Negotiating Parties: JDM Properties
Under Negotiation: Price and Terms of Payment
2. Real Property Transaction – 2020 and 2100 Hoover Avenue, National City
APN's: 559-104-10; 559-124-05; 559-125-15; 560-206-05; 560-391-05; 560-391-08;
560-391-10; and 560-396-06
City Negotiator: Brad Raulston
CDC-HA Negotiator: Alfredo Ybarra
Under Negotiation: Price and Terms of Payment

COMMUNITY DEVELOPMENT COMMISSION – HOUSING AUTHORITY

1. Real Property Transaction – 2020 and 2100 Hoover Avenue, National City
APN's: 559-104-10; 559-124-05; 559-125-15; 560-206-05; 560-391-05; 560-391-08;
560-391-10; and 560-396-06
City Negotiator: Brad Raulston
CDC-HA Negotiator: Alfredo Ybarra
Under Negotiation: Price and Terms of Payment

CLOSED SESSION

CITY COUNCIL

1. Conference with Legal Counsel – Existing Litigation
Government Code Section 54956.9(a)
People v. Quiambao; (Rescue Homes: 811 "N" Avenue and 834 Delta Street)
San Diego County Superior Court Case No. 37-2011-00099379
2. Real Property Transaction – 1726 Wilson Avenue, National City
APN: 559-086-03-00
Agency Negotiator: Brad Raulston
Negotiating Parties: JDM Properties
Under Negotiation: Price and Terms of Payment
3. Real Property Transaction – 2020 and 2100 Hoover Avenue, National City
APN's: 559-104-10; 559-124-05; 559-125-15; 560-206-05; 560-391-05; 560-391-08;
560-391-10; and 560-396-06
City Negotiator: Brad Raulston
CDC-HA Negotiator: Alfredo Ybarra
Under Negotiation: Price and Terms of Payment

COMMUNITY DEVELOPMENT COMMISSION – HOUSING AUTHORITY

1. Real Property Transaction – 2020 and 2100 Hoover Avenue, National City
APN's: 559-104-10; 559-124-05; 559-125-15; 560-206-05; 560-391-05; 560-391-08;
560-391-10; and 560-396-06
City Negotiator: Brad Raulston
CDC-HA Negotiator: Alfredo Ybarra
Under Negotiation: Price and Terms of Payment

ADJOURNMENT

Next Regular City Council / CDC Meeting – Tuesday, August 6, 2013, 5:00 p.m., Council Chambers, Civic Center

DRAFT DRAFT DRAFT

**MINUTES OF THE SPECIAL MEETING OF THE
CITY COUNCIL AND COMMUNITY DEVELOPMENT COMMISSION
– HOUSING AUTHORITY OF THE CITY OF NATIONAL CITY**

August 6, 2013

The Special Meeting of the City Council and Community Development Commission – Housing Authority of the City of National City was called to order at 4:07 p.m. by Mayor / Chairman Ron Morrison.

ROLL CALL

Council / Board members present: Cano, Morrison, Rios, Sotelo-Solis.
Council / Board members absent: Natividad

OPEN SESSION

The below listed items were introduced on the Public Agenda.

CITY COUNCIL

1. Real Property Transaction – 1726 Wilson Avenue, National City
APN: 559-086-03-00
Agency Negotiator: Brad Raulston
Negotiating Parties: JDM Properties
Under Negotiation: Price and Terms of Payment
2. Real Property Transaction – 2020 and 2100 Hoover Avenue, National City
APN's: 559-104-10; 559-124-05; 559-125-15; 560-206-05; 560-391-05;
560-391-08; 560-391-10; and 560-396-06
City Negotiator: Brad Raulston
CDC-HA Negotiator: Alfredo Ybarra
Under Negotiation: Price and Terms of Payment

COMMUNITY DEVELOPMENT COMMISSION – HOUSING AUTHORITY

1. Real Property Transaction – 2020 and 2100 Hoover Avenue, National City
APN's: 559-104-10; 559-124-05; 559-125-15; 560-206-05; 560-391-05;
560-391-08; 560-391-10; and 560-396-06
City Negotiator: Brad Raulston
CDC-HA Negotiator: Alfredo Ybarra
Under Negotiation: Price and Terms of Payment

OPEN SESSION (cont.)

ACTION: Motion by Sotelo-Solis, seconded by Rios, to go into Closed Session. Motion carried by the following vote, to-wit: Ayes: Cano, Morrison, Rios, Sotelo-Solis. Nays: None. Absent: Natividad. Abstain: None.

Members retired into Closed Session at 4:08 pm.

City Clerk

The foregoing minutes were approved at the Regular Meeting of September 17, 2013.

Mayor

**CITY OF NATIONAL CITY, CALIFORNIA
COUNCIL AGENDA STATEMENT**

MEETING DATE: September 17, 2013

AGENDA ITEM NO. |

ITEM TITLE: Resolution of the City Council of the City of National City authorizing the Mayor to execute a Fourth Amendment to the Agreement for Legal Services by Best Best & Krieger, LLP, for the Community Youth Athletic Center legal challenge defense to increase the not to exceed amount by \$53,500 for a total not-to-exceed amount of \$462,500.

PREPARED BY: Claudia Gacitua Silva

DEPARTMENT: City Attorney

PHONE: Ext. 4222

APPROVED BY: 

EXPLANATION:

Please see attached staff report.

FINANCIAL STATEMENT:

ACCOUNT NO. |

Funds are budgeted in Account 711-409-000-209-0000.

APPROVED: _____ Finance

APPROVED: _____ MIS

ENVIRONMENTAL REVIEW:

N/A

ORDINANCE: INTRODUCTION: FINAL ADOPTION:

STAFF RECOMMENDATION:

Adopt proposed resolution.

BOARD / COMMISSION RECOMMENDATION:

N/A

ATTACHMENTS:

Staff report
Fourth Amendment to the Agreement with BB&K for Legal Services
Proposed resolution

STAFF REPORT

This matter is a result of the Community Youth Athletic Center (“CYAC”) legal challenge to the 2007 Redevelopment Plan Amendment. In addition to the Plan Amendment challenge, the CYAC made other claims, including violations of the Public Records Act and due process. This lawsuit has been working its way through the legal system since the Fall of 2007. Currently, the case is on appeal from Judge Denton’s decision. Judge Denton invalidated the 2007 Redevelopment Plan Amendment, found that the Public Records Act was not complied with when draft notes and consultant’s documents were not provided, and found the CYAC was not provided due process because they did not have sufficient time to object to the plan amendment. CYAC has cross-appealed on all the claims in which the Court held against them. The Court’s award of attorney’s fees totaling approximately two-million dollars (\$2,000,000) has been also appealed to the 4th District Court of Appeals.

Bruce Beach and Rebecca Andrews of Best Best & Krieger, LLP (“BB&K”) have been our outside counsel in this case. Given the nature and length of the case, additional funds in the amount of \$53,500 are needed for the on-going appeal.

The City Council has previously approved the following:

1. Original Agreement for Legal Services in the amount of \$160,000 (November 12, 2010).
2. First Amendment to the Agreement in the amount of \$134,000 (October 18, 2011).
3. Second Amendment to the Agreement in the amount of \$70,000 (May 15, 2012).
4. Third Amendment to the Agreement in the amount of \$45,000 (October 30, 2012).

This Fourth Amendment to the Agreement in the amount of \$53,500 is necessary for the on-going appeal process, which will bring the total not-to-exceed amount to \$462,500. The appeal process is anticipated to be completed and decision rendered within the next 12 months. Because all redevelopment agencies were dissolved by the State, this Fourth Amendment is between the Successor Agency to the Community Development Commission as the National City Redevelopment Agency and BB&K. The Fourth Amendment will also require the approval of the Oversight Board to the Successor Agency prior to being effective.

**FOURTH AMENDMENT TO AGREEMENT
BY AND BETWEEN
THE CITY OF NATIONAL CITY,
THE SUCCESSOR AGENCY
TO THE COMMUNITY DEVELOPMENT COMMISSION
AS THE NATIONAL CITY REDEVELOPMENT AGENCY
AND
BEST BEST & KRIEGER, LLP**

This Fourth Amendment to Agreement is entered into this 3rd day of September, 2013, by and between THE CITY OF NATIONAL CITY, a municipal corporation, (the "CITY"), THE SUCCESSOR AGENCY TO THE COMMUNITY DEVELOPMENT COMMISSION AS THE NATIONAL CITY REDEVELOPMENT AGENCY, a public body, corporate and politic, (the "SUCCESSOR AGENCY"), and BEST BEST & KRIEGER, LLP, (the "FIRM").

RECITALS

- A. The CITY, the SUCCESSOR AGENCY and the FIRM (the "Parties") entered into an agreement on October 9, 2010, ("the Agreement") wherein the FIRM agreed to provide legal services in the defense of the case entitled *Community Youth Athletic Association v. All Persons Interested in the Matter of the Amendment to National City's Redevelopment Plan as Adopted by Ordinance 2007-2295*, Case No. 37-2007-00076404-CU-EI-CTL, in the amount of \$160,000, and subject to the terms of the Agreement.
- B. The Parties entered into the First Amendment to the Agreement on October 18, 2011, (the "First Amendment") to increase the not-to-exceed amount of the Agreement by \$134,000, for a total Agreement not-to-exceed amount of \$294,000.
- C. The Parties entered into a Second Amendment on May 15, 2012 to increase the not-to-exceed amount by \$70,000 for a total not-to-exceed amount of \$364,000.
- D. The Parties entered into a Third Amendment on October 30, 2012 to increase the not-to-exceed amount of the Agreement by \$45,000 for a total not-to-exceed amount of \$409,000.
- E. The Parties desire to amend the Agreement to increase the not-to-exceed amount of the Agreement by \$53,500 for a total not-to-exceed amount of \$462,500.
- F. The case remains on-going as it is on appeal, and requires continued legal representation.
- G. On January 10, 2012, the City Council adopted Resolution No. 2012-15, pursuant to Part 1.85 of the California Health and Safety Code, electing for the City to serve as the successor agency to the CDC upon the dissolution of the Redevelopment Agency.
- H. On February 1, 2012, all California redevelopment agencies were dissolved, successor agencies were established as successor agencies to the former redevelopment agencies pursuant to Health and Safety Code Section 34173, and successor agencies are tasked with paying, performing and enforcing the enforceable obligations of the former redevelopment agencies.

I. This Fourth Amendment will require the approval of the Oversight Board to the Successor Agency prior to being effective.

NOW, THEREFORE, the Parties agree that the Agreement entered into on October 9, 2010, and amended on October 18, 2011, May 15, 2012, and October 30, 2012, shall be amended by amending Article 3 (Compensation), Section C of the Agreement by increasing the not-to-exceed amount by \$53,500 for a total not-to-exceed amount of \$462,500.

The parties further agree that with the foregoing exception, each and every term and provision of the Agreement dated October 9, 2010, shall remain in full force and effect.

IN WITNESS WHEREOF, the parties hereto have executed this Fourth Amendment to the Agreement on the date and year first above written.

**SUCCESSOR AGENCY TO
THE COMMUNITY DEVELOPMENT
COMMISSION AS THE NATIONAL CITY
REDEVELOPMENT AGENCY**

BEST, BEST, & KRIEGER, LLP

By: _____
Ron Morrison, Chairman

By: _____
Bruce Beach, Esq.

APPROVED AS TO FORM:

By: _____
Claudia Gacitua Silva
Successor Agency Counsel

CITY OF NATIONAL CITY

By: _____
Ron Morrison, Mayor

APPROVED AS TO FORM:

By: _____
Claudia Gacitua Silva
City Attorney

RESOLUTION NO. 2013 –

RESOLUTION OF THE CITY COUNCIL OF THE CITY OF NATIONAL CITY
AUTHORIZING THE MAYOR TO EXECUTE A FOURTH AMENDMENT
TO THE AGREEMENT FOR LEGAL SERVICES BY
BEST BEST & KRIEGER, LLP, FOR THE CYAC LEGAL CHALLENGE
DEFENSE TO INCREASE THE NOT TO EXCEED AMOUNT
BY \$53,500 FOR A TOTAL AMOUNT OF \$462,500

WHEREAS, on November 23, 2010, the City Council adopted Resolution No. 2010-254 approving an Agreement between the City of National City, the CDC, and Best Best & Krieger, LLP (“BB&K”), to provide legal defense services regarding the Community Youth Athletic Center (“CYAC”) litigation in the not to exceed amount of \$160,000; and

WHEREAS, on October 18, 2011, the City Council adopted Resolution No. 2011-229 approving the First Amendment to the Agreement that increased the not to exceed amount by \$134,000, bringing the total not to exceed amount to \$294,000; and

WHEREAS, on May 15, 2012, the City Council adopted Resolution No. 2012-105 authorizing the Second Amendment to the Agreement in the amount of \$70,000 for the on-going appeal process, for a total not-to-exceed amount of \$364,000; and

WHEREAS, on October 30, 2012, the City Council adopted Resolution No. 2012-220 authorizing the Third Amendment to the Agreement in the amount of \$45,000 for the on-going appeal process, for a total not-to-exceed amount of \$409,000; and

WHEREAS, a Fourth Amendment to the Agreement in the amount of \$53,500 is necessary for the final process of the appeal, which will bring the total not-to-exceed amount to \$462,500; and

WHEREAS, the Fourth Amendment must also be approved by the Oversight Board to the Successor Agency prior to being effective.

NOW, THEREFORE, BE IT RESOLVED that the City Council of the City of National City hereby authorizes the Mayor to execute the Fourth Amendment to the Agreement with Best Best & Krieger, LLP (“BB&K”), to increase the not to exceed amount by \$53,500, for a total not to exceed amount of \$462,500, to cover legal services for the appeal regarding the Community Youth Athletic Center (“CYAC”) litigation. Said Fourth Amendment to the Agreement is on file in the office of the City Clerk.

PASSED and ADOPTED this 17th day of September, 2013.

Ron Morrison, Mayor

ATTEST:

APPROVED AS TO FORM:

Michael R. Dalla, City Clerk

Claudia Gacitua Silva
City Attorney

**CITY OF NATIONAL CITY, CALIFORNIA
COUNCIL AGENDA STATEMENT**

MEETING DATE: September 17, 2013

AGENDA ITEM NO. _____

ITEM TITLE:

Resolution of the City Council of the City of National City adopting a Safe Harbors under the Patient Protection and Affordable Care Act

PREPARED BY: Stacey Stevenson

DEPARTMENT: Human Resources

PHONE: 336-4308

APPROVED BY: _____

EXPLANATION:

On March 23, 2010, the federal government enacted comprehensive health care reform: The Patient Protection and Affordable Care Act. The intent of the Act is to make preventative health care more accessible and affordable for many Americans. The numerous provisions of the Act are phased in over several years. At this time, it is anticipated that Title 26 of the United States Code Section 4980H Shared Responsibility for Employers Regarding Health Care Coverage will become effective for the 2014 benefits plan year. Title 26, known as the "Play or Pay" provision requires large employers, such as the City of National City (employing on average at least 50 full-time employees), to offer full-time employees the opportunity to enroll in minimum essential coverage under an eligible employer-sponsored health care plan. The purpose of this action is to establish a look-back safe harbor measurement period for purposes of determining employee eligibility for those employees not anticipated to be work on a full-time basis as defined by the Act.

As drafted, for employees hired as less than full-time (working an average of 30 hours per week over a twelve month measurement period), the City will annually look back to verify the part-time status. If any employees are found to have met the definition of full-time, said employees will be offered health care benefits for a period of time equal to the measurement period, following a 60 day administrative period. The recommended measurement period is December 2 through December 1 of each year, beginning December 2, 2013.

FINANCIAL STATEMENT:

APPROVED: _____ **Finance**

ACCOUNT NO.

APPROVED: _____ **MIS**

There is no financial impact associated with this item.

ENVIRONMENTAL REVIEW:

This is not a project and, therefore, is not subject to environmental review.

ORDINANCE: **INTRODUCTION:** **FINAL ADOPTION:**

STAFF RECOMMENDATION:

Adopt the resolution enacting Safe Harbors under the Patient Protection and Affordable Care Act

BOARD / COMMISSION RECOMMENDATION:

N/A

ATTACHMENTS:

Resolution

RESOLUTION NO. 2013 –

RESOLUTION OF THE CITY COUNCIL OF THE CITY OF NATIONAL CITY
ADOPTING SAFE HARBORS UNDER THE PATIENT PROTECTION
AND AFFORDABLE CARE ACT

WHEREAS, the Patient Protection and Affordable Care Act (“ACA”) was enacted on March 23, 2010; and

WHEREAS, ACA added Section 4980H Shared Responsibility for Employers Regarding Health Care Coverage to Title 26 of the United States Code, the Internal Revenue Code (Section 4980H); and

WHEREAS, Section 4980H imposes an assessable payment on an applicable large employer when (1) it fails to offer “substantially all” of its full-time employees (and their dependents) the opportunity to enroll in minimum essential coverage or offers coverage to “substantially all” of its full-time employees (and their dependents) that is “unaffordable” or does not provide “minimum value” and (2) any full-time employee is certified to the employer as having received a subsidy for coverage through the exchange (“Assessable Payment”); and

WHEREAS, the City of National City is considered an applicable large employer because it employed an average of at least 50 full-time employees (including full-time equivalents) on business days during the preceding calendar year; and

WHEREAS, the Department of Treasury issued proposed regulations regarding Section 4980H that permit the City to adopt a Look-Back Measurement Method Safe Harbor (“Look Back Safe Harbor”) in order to determine the status of an employee as full-time for purposes of determining and calculating the Assessable Payment (78 Federal Register 218, 243, January 2, 2013); and

WHEREAS, the City intends to adopt the provisions of the Look-Back Measurement Method Safe Harbor in order to determine the full-time status of employees for purposes of the Assessable Payment, where Section 4980H defines “full-time” status as “an employee who is employed on average at least 30 hours of service per week”; and

WHEREAS, the Department of Treasury issued proposed regulations regarding Section 4980H that permit the City to use one of three affordability safe harbors for any reasonable category of employees as long as it is applied on a uniform and consistent basis for all employees in the category (78 Federal Register 218, 251-253, January 2, 2013); and

WHEREAS, the City intends to use the affordability safe harbors as contemplated in the proposed regulations.

NOW THEREFORE, be it resolved by the City Council for the City of National City, as follows:

Section 1. The City establishes the Look-Back Measurement Method Safe Harbor for all ongoing employees as follows:

- a. The City establishes a twelve (12) month standard measurement period for ongoing employees.

- b. The standard measurement period will start each year on December 2 and end the following year on December 1. The initial term will be December 2, 2013 through December 1, 2014.
- c. The standard measurement period is the period during which an ongoing employee's hours are measured.
- d. The City establishes an administrative period of sixty (60) days.
- e. The administrative period associated with the standard measurement period will start each year on December 2 and end on January 31.
- f. The City establishes a twelve (12) month stability period for ongoing employees.
- g. Starting with February 1, 2015, the twelve (12) month stability period for ongoing employees will start each year on February 1 and end on January 31.
- h. If an ongoing employee's employment status changes before the end of a stability period, the change in status will not affect the classification of the employee (as full time or not full time) for the remaining portion of the stability period.

Section 2. On the start date of a new employee, the City will make a determination as to whether that new employee is reasonably expected to be a full-time employee. If the new employee is reasonably expected to be a full-time employee and is not a seasonal employee, the City will offer minimum essential coverage to that employee within 60 days.

Section 3. If based on the facts and circumstances, on the start date of a new employee, the City is unable to determine that the employee is reasonably expected to be employed an average of at least thirty (30) hours per week over the initial measurement period, then the employee is considered a variable hour employee.

Section 4. The City establishes the Look-Back Safe Harbor for new variable hour employees as follows:

- a. The City establishes a twelve (12) month initial measurement period for each new employee.
- b. The initial measurement period will start the first day of the first calendar month after the start date, unless the start date is the first of a calendar month in which case the initial measurement period will start on that date.
- c. The administrative period shall start the day following the last day of the initial measurement period and shall end no later than the last day of the first calendar month beginning on or after the first anniversary of the employee's start date.

- d. The City establishes a twelve (12) month stability period associated with the initial measurement period.
- e. If the new variable hour employee does not measure as a full-time employee during the initial measurement period, the stability period associated with the initial measurement period must not exceed the remainder of the standard measurement period (plus any associated administrative period).

Section 5. A new employee's hours will be measured during the first complete standard measurement period for which he/she is employed. This means that a new employee's status may be tested under an initial measurement period and at the same time be measured under the overlapping standard measurement period.

- a. If an employee measures as full-time during the initial measurement period, he/she will retain full-time status for the entire associated stability period (even if the employee does not qualify as full-time during the standard measurement period).
- b. If an employee does not measure as full-time during the initial measurement period, but qualifies as full-time during the standard measurement period, the employee must be treated as full-time during the stability period associated with the standard measurement period.

Section 6. When an employee experiences a break in service without providing at least one hour of service, the employee will retain the status the employee had previously with respect to any stability period, except that an employee will be treated as a new employee:

- a. if the employee resumes employment after a period of at least 26 consecutive weeks with less than an hour of service; or
- b. if the employee's period of no service (measured in weeks) is at least four consecutive weeks long and exceeds the number of weeks of that employee's period of employment immediately preceding the period of no service.

Section 7. When an employee takes special unpaid leave (i.e. unpaid leave under the Family and Medical Leave Act of 1993, unpaid leave under the Uniformed Services Employment and Reemployment Rights Act of 1994, or unpaid leave on account of jury duty), to determine hours of service the City will compute the average after excluding any periods of special unpaid leave during the measurement period and apply that average for the entire measurement period.

Section 8. For each reasonable category of employees, the City, at its sole discretion, but on a uniform and consistent basis for all of the employees in a reasonable category, will apply one of the following safe-harbors to determine the affordability of the minimum essential coverage that it offers its full-time employees:

- a. Form W-2 Safe Harbor
 - i. The City measures whether the employee's required contribution for the calendar month for the lowest cost self-only coverage that provides minimum value exceeds 9.5 percent of the Form W-2 wages (as reported in Box 1) for the employee from the employer for the calendar year in which coverage is offered.
 - ii. The coverage offered by the City will be deemed affordable if the employee's contribution is equal to or less than 9.5% of the employee's Form W-2 wages as reported in Box 1.

- b. Rate of Pay Safe Harbor
 - i. The City measures whether the employee's required contribution for the calendar month for the lowest cost self-only coverage that provides minimum value exceeds 9.5 percent of an amount equal to 130 hours multiplied by the employee's hourly rate of pay as of the first day of the coverage period.
 - ii. For salaried employees, the monthly salary amount will be used instead of 130 multiplied by the hourly rate of pay.
 - iii. The City may use this safe harbor only if the City does not reduce the employee's wages (with respect to the employees for whom the City applies the safe harbor).
 - iv. If rate of pay increases during the year, the City will use the lowest rate of pay for the year in the calculation.
 - v. The coverage offered by the City will be deemed affordable if the employee's monthly contribution is equal to or less than 9.5 percent of the monthly wage as calculated in (b)(i)-(ii) above.

- c. Federal Poverty Line Safe Harbor
 - i. The City measures whether the employee's required contribution for the calendar month for the lowest cost self-only coverage that provides minimum value exceeds 9.5 percent of a monthly amount determined as the Federal Poverty Line (FPL) for a single individual for the applicable calendar year.
 - ii. The coverage offered by the City will be deemed affordable if the employee's monthly contribution does not exceed 9.5 percent of the monthly FPL for a single individual for the applicable calendar year.

Resolution No. 2013 –
September 17, 2013
Page Five

PASSED and ADOPTED this 17th day of September, 2013.

Ron Morrison, Mayor

ATTEST:

Michael R. Dalla, City Clerk

APPROVED AS TO FORM:

Claudia Gacitua Silva
City Attorney

**CITY OF NATIONAL CITY, CALIFORNIA
COUNCIL AGENDA STATEMENT**

MEETING DATE: September 17, 2013

AGENDA ITEM NO. _____

ITEM TITLE:

Resolution of the City Council of the City of National City reaffirming the Phase III Expansion of the San Diego Convention Center

PREPARED BY: Leslie Deese, City Manager

DEPARTMENT: City Manager

PHONE: 619-336-4240 

APPROVED BY: _____

EXPLANATION:

See attached report.

FINANCIAL STATEMENT:

ACCOUNT NO.

N/A

APPROVED: _____ Finance

APPROVED: _____ MIS

ENVIRONMENTAL REVIEW:

N/A

ORDINANCE: INTRODUCTION: FINAL ADOPTION:

STAFF RECOMMENDATION:

Staff recommends the City Council approve the resolution reaffirming its support for the Phase III Expansion of the San Diego Convention Center and urges the California Coastal Commission to approve the project at its October 2013 Hearing.

BOARD / COMMISSION RECOMMENDATION:

N/A

ATTACHMENTS:

Staff Report
Council Agenda Statement of November 15, 2011
City Council Minutes of November 15, 2011
Resolution

Staff Report: Resolution of the City Council Reaffirming the Phase III Expansion of the San Diego Convention Center

The purpose of this item is to request the City Council reaffirm its support for the Phase III Expansion of the San Diego Convention Center and urge the California Coastal Commission to approve the project at its October 2013 hearing.

Background:

On November 15, 2011, the City Council voted to support the expansion of the San Diego Convention Center (attached).

At the request of the San Diego Unified Port District, the City Council is being asked to reaffirm their support for the current plan to expand the convention center to meet market demand, address lost business concerns and build on the success of the current facility while also generating new job and regional economic benefit. The request is in response to a proposal by the San Diego Chargers to include a football stadium in the project.

The expansion plan, estimated at \$520 million dollars, goes before the California Coastal Commission for approval next month. If approved, the expansion would create a total area of 2.75 million square feet which is the most contiguous floor space on the West Coast. According to project supporters, San Diego is losing an estimated 25 major gatherings per year because it needs more connected space; the expansion is also critical to keeping Comic-Con International, the largest annual trade show in San Diego.

Staff Recommendation:

Staff recommends the City Council approve the resolution reaffirming its support for the Phase III Expansion of the San Diego Convention Center and urges the California Coastal Commission to approve the project at its October 2013 hearing.

CITY OF NATIONAL CITY, CALIFORNIA
COUNCIL AGENDA STATEMENT

MEETING DATE: November 15, 2011

ADDED ITEM

AGENDA ITEM NO. |

ITEM TITLE:

A Resolution of the City Council of the City of National City supporting the San Diego Convention Center Phase III Expansion Project.

PREPARED BY: Chris Zapata, City Manager

PHONE: 619-336-4240

DEPARTMENT:

APPROVED BY: 

EXPLANATION:

See Attached.

FINANCIAL STATEMENT:

ACCOUNT NO.

N/A

APPROVED: _____

Finance

APPROVED: _____

MIS

ENVIRONMENTAL REVIEW:

N/A

ORDINANCE: INTRODUCTION:

FINAL ADOPTION:

STAFF RECOMMENDATION:

Staff Recommends that the City Council approve the Resolution.

BOARD / COMMISSION RECOMMENDATION:

N/A

ATTACHMENTS:

Resolution

**RESOLUTION OF THE CITY COUNCIL OF THE CITY OF NATIONAL CITY IN
SUPPORT OF THE SAN DIEGO CONVENTION CENTER PHASE III
EXPANSION PROJECT**

San Diego Mayor Jerry Sanders has requested a long term financial commitment to expand the San Diego Convention Center and has requested the Unified Port of San Diego fund \$60 million for a period of 20-years for this project. The Port is scheduled to hold a special meeting on November 29, 2011 to discuss and consider this funding request further (It is not known at this time whether the scheduled meeting is going to be an open or closed meeting.) In response, staff is recommending the City Council approve a draft resolution as an added item to the November 15, 2011 agenda.

The proposed expansion is expected to generate \$698 million of economic activity annually in addition to the \$1.3 billion a year the San Diego Convention Center already generates, plus \$15 million in new revenues for San Diego and nearly 7,000 permanent jobs.

Staff recommends the City Council approve the Resolution which supports the convention center expansion if a proportionate investment is made in other Port cities similar to the 1995 Memorandum of Understanding (MOU) which was drafted and passed when the second phase of the Convention Center was requested. This MOU provided significant resources to the other four South Bay cities and is proposed as a model for this request by San Diego. This proportionate investment would not be in lieu of existing commitments by the Port and would be aimed at helping cities realize projects that generate revenue and quality of life.

RESOLUTION NO. 2011 – 251

RESOLUTION OF THE CITY COUNCIL OF
THE CITY OF NATIONAL CITY SUPPORTING
THE SAN DIEGO CONVENTION CENTER
PHASE III EXPANSION PROJECT

WHEREAS, the cities of National City, Chula Vista, Coronado, Imperial Beach, and San Diego comprise the San Diego Unified Port District; and

WHEREAS, the proposed \$550 Million expansion of the San Diego Convention Center would increase its size by approximately one-third, and would create the largest contiguous exhibit hall west of the Mississippi River and the largest ballroom of any conventional facility along the West Coast; and

WHEREAS, San Diego Mayor Jerry Sander's Citizen Task Force estimates that the proposed expansion is expected to generate \$698 Million of economic activity annually in addition to the \$1.3 Billion a year the San Diego Convention Center already generates, plus \$15 Million in new revenues for San Diego, and nearly 7,000 permanent jobs; and

WHEREAS, on October 10, 2011, the San Diego City Council approved a three-tier taxing formula based on proximity to the San Diego Convention Center and percentage of room revenue that is expected to raise a substantial amount of funding needed to pay for the expansion; and

WHEREAS, the Mayor of the City of San Diego is requesting a long term financial commitment to expand the San Diego Convention Center, and has requested the Unified Port of San Diego fund \$60 Million for a period of 20 years for this project; and

WHEREAS, the Unified Port of San Diego will hold a special meeting on November 29, 2011, to discuss and consider this funding request further; and

WHEREAS, the City of National City, as a member city of the Unified Port of San Diego, supports the expansion of the San Diego Convention Center and the economic well-being of the region; and

WHEREAS, the City of National City supports the San Diego Convention Center expansion if a proportionate increase in the amount of revenue producing/quality of life funding is provided to the four San Diego Unified Port member cities of National City, Chula Vista, Coronado, and Imperial Beach for a 20-year period, similar in concept to the 1995 Memorandum of Understanding between the Unified Port of San Diego and its member cities; and

WHEREAS, the expansion of the San Diego Convention Center, along with a parallel Memorandum of Understanding, creates a win for City of San Diego, a win for the Region, and a win for the South Bay cities.

NOW, THEREFORE, BE IT RESOLVED that the City Council of the City of National City hereby supports the San Diego Convention Center Phase III Expansion Project and a new Memorandum of Understanding for the Unified Port of San Diego member cities.

--- Signature Page to Follow ---

PASSED and ADOPTED this 15th day of November, 2011.



Ron Morrison, Mayor

ATTEST:



Michael R. Dalla, City Clerk

APPROVED AS TO FORM:

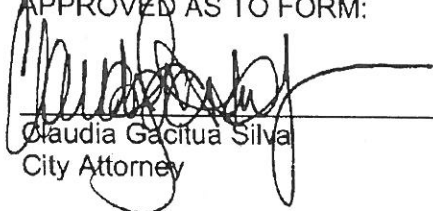

Claudia Gacitua Silva
City Attorney

Passed and adopted by the Council of the City of National City, California, on November 15, 2011 by the following vote, to-wit:

Ayes: Councilmembers Morrison, Natividad, Rios, Sotelo-Solis, Zarate.

Nays: None.

Absent: None.

Abstain: None.

AUTHENTICATED BY: RON MORRISON
Mayor of the City of National City, California



Richard S. Palma
City Clerk of the City of National City, California

By: _____
Deputy

I HEREBY CERTIFY that the above and foregoing is a full, true and correct copy of RESOLUTION NO. 2011-251 of the City of National City, California, passed and adopted by the Council of said City on November 15, 2011.

City Clerk of the City of National City, California

By: _____
Deputy

**MINUTES OF THE REGULAR MEETING OF THE CITY COUNCIL
AND COMMUNITY DEVELOPMENT COMMISSION
OF NATIONAL CITY, CALIFORNIA**

November 15, 2011

The Regular Meeting of the City Council and Community Development Commission of National City was called to order at 6:11 p.m. by Mayor / Chairman Ron Morrison.

ROLL CALL

Council / Commission members present: Morrison, Natividad, Rios, Sotelo-Solis, Zarate.

Administrative Officials present: Babaki, Dalla, Deese, Duong, Norrdin, Parra, Raulston, Rodriguez, Silva, Smith, Stevenson, Williams, Zapata.

Others present: City Treasurer Mitch Beauchamp and Student Representatives Aileen Horta and Leemaylin Avila.

PLEDGE OF ALLEGIANCE TO THE FLAG BY MAYOR RON MORRISON

PUBLIC ORAL COMMUNICATIONS

Sunshine Horton, El Cajon, invited everyone to attend the Mother Goose Parade.

Mark Lovato, Cornerstone Church of San Diego, extended an invitation to the City Council and staff to attend their annual Thanksgiving community dinner on November 20th at Sweetwater High School.

OFF AGENDA ITEM

Mayor Morrison indicated that there was an item for consideration that came up after the posting of the agenda that should be added to the agenda.

SUBJECT: RESOLUTION OF THE CITY COUNCIL OF THE CITY OF NATIONAL CITY SUPPORTING THE SAN DIEGO CONVENTION CENTER PHASE III EXPANSION PROJECT.

RECOMMENDATION: Add the Item.

ACTION: Motion by Sotelo-Solis, seconded by Natividad, to bring the item onto the Agenda as Item No. 25a. Carried by unanimous vote.

RESOLUTION NO. 2013 –

RESOLUTION OF THE CITY COUNCIL OF THE CITY OF NATIONAL CITY
REAFFIRMING SUPPORT OF THE SAN DIEGO CONVENTION CENTER
PHASE III EXPANSION PROJECT

WHEREAS, on November 15, 2011, the City Council of the City of National City adopted Resolution 2011-251 in support of the San Diego Convention Center Phase III Expansion Project; and

WHEREAS, according to data compiled by the San Diego Convention Center Corporation, the San Diego Convention Center has generated over \$22 billion in regional economic impacts since opening in 1989 and is directly responsible for 12,500 permanent jobs throughout San Diego County; and

WHEREAS, the Convention Center is the cornerstone of the region's third largest traded cluster, the visitor industry, which employs 13 percent of the region's workforce; and

WHEREAS, based on the recommendations of a citizen's task force and substantial community and stakeholder input, a Phase III Expansion of the current facility is being proposed to meet market demand, address lost business concerns, and build on the success of the current facility while also generating new jobs and regional economic benefits; and

WHEREAS, the Phase III Expansion will attract an additional 25 primary events and nearly 250,000 additional attendees which will create positive regional economic impacts of \$689 million and 6,685 new permanent jobs; and

WHEREAS, the Phase III Expansion will also create a new five-acre elevated public park and substantial retail uses to activate and create a visitor destination on the Bayfront; and

WHEREAS, the Phase III Expansion will maximize and greatly enhance public access and public recreational opportunities for San Diegans as well as visitors on the Bayfront consistent with the California Coastal Act; and

WHEREAS, the Phase III Expansion, its economic impacts, its proposed location and its public realm amenities have the enthusiastic support of neighborhoods surrounding the proposed Phase III Expansion, the greater San Diego region, and diverse business and labor organizations;

NOW, THEREFORE, BE IT RESOLVED that the Council of the City of National City that this Council hereby affirms its support for the Phase III Expansion of the San Diego Convention Center and urges the California Coastal Commission to approve the project at its October 2013 hearing.

--- Signature Page to Follow ---

Resolution No. 2013 –
September 17, 2013
Page Five

PASSED and ADOPTED this 17th day of September, 2013.

Ron Morrison, Mayor

ATTEST:

Michael R. Dalla, City Clerk

APPROVED AS TO FORM:

Claudia Gacitua Silva
City Attorney

**CITY OF NATIONAL CITY, CALIFORNIA
COUNCIL AGENDA STATEMENT**

MEETING DATE: September 17, 2013

AGENDA ITEM NO.

ITEM TITLE:

Resolution of the City Council of the City of National City, 1) awarding a contract in the not to exceed amount of \$3,524,896.00 to EC Constructors, Inc. for the National City Aquatic Center Project, Specification No. 13-04; 2) authorizing a 15% contingency in the amount of \$528,734.40 for any unforeseen changes; and 3) authorizing the Mayor to execute the contract (funded by San Diego Unified Port District CIP)

PREPARED BY: Stephen Manganiello

PHONE: 336-4382

EXPLANATION:

See attached.

DEPARTMENT: Engineering

APPROVED BY: _____

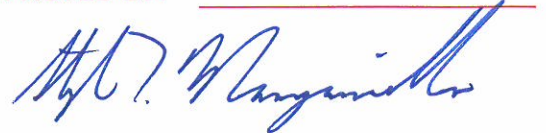

FINANCIAL STATEMENT:

ACCOUNT NO.

\$3,080,000: 296-409-500-598-3816 (SDUPD CIP – reimbursable)
\$444,896: 001-409-500-598-3816 (SDUPD CIP)

APPROVED: _____

Finance

APPROVED: _____

MIS

ENVIRONMENTAL REVIEW:

N/A

ORDINANCE: INTRODUCTION:

FINAL ADOPTION:

STAFF RECOMMENDATION:

Adopt the Resolution.

BOARD / COMMISSION RECOMMENDATION:

N/A

ATTACHMENTS:

1. Explanation
2. Bid Opening Summary
3. Three Lowest Bidders Summary
4. Resolution

EXPLANATION

The National City Aquatic Center Project, Specification No. 13-04, consists of the demolition of site items, construction of new Aquatics Center Buildings and all site improvements, complete and in-place as a turn-key project.

In July, 2013, the bid solicitation was advertised in local newspapers and posted on the City's website.

On August 20, 2013, eleven (11) sealed bids were received by the 11:00 a.m. deadline, opened and publically disclosed. Precise Construction Management was the apparent low bidder with a total bid amount of \$3,170,000.00. However, due to a clerical error, Precise Construction Management withdrew their bid.

Watkins Landmark Construction was the second apparent low bidder with a total bid amount of \$3,445,950.00. However, their bid was deemed "non-responsive".

EC Constructors, Inc. was the third apparent low bidder with a total bid amount of \$3,524,896.00. Upon review of all documents submitted and reference checks, EC Constructors' bid is responsive, and they are the lowest responsible bidder qualified to perform the work as described in the project specifications.

Attached are the bid opening results and a summary of the three lowest bidders for your information.

The San Diego Unified Port District (SDUPD) has allocated a total of \$3,910,000 towards the National City Aquatic Center as part of its Capital Improvement Program. The SDUPD previously submitted a project payment to the City of National City in the amount of \$830,000. The remaining \$3,080,000 is available as reimbursement for project expenditures.

Staff recommends the following: 1) award a contract in the not to exceed amount of \$3,524,896.00 to EC Constructors, Inc. for the National City Aquatic Center Project, Specification No. 13-04; 2) authorize a 15% contingency in the amount of \$528,734.40 for any unforeseen changes; and 3) authorize the Mayor to execute the contract



BID OPENING

SPECIFICATION NO: 13-04
 PROJECT TITLE: NATIONAL CITY AQUATIC CENTER
 TIME: 11:00 A.M.
 DATE: TUESDAY, AUGUST 20, 2013
 ESTIMATE: \$3,240,000.

No.	Bidder's Name	Bid Amount	Addenda	Bid Security
1.	Precise Construction Management 3970 Tynebourne Circle San Diego, 92130	\$3,170,000	1-6	Bond
2.	Watkins Landmark Construction 560 Stevens Avenue Solana Beach, CA 92075	\$3,445,950	1-6	Bond
3.	EC Constructors 9834 River Street Lakeside, CA 92040	\$3,524,896	1-6	Bond
4.	Fordyce Construction, Inc. 9932 Prospect Avenue #138 Santee, CA 92071	\$3,525,390	1-6	Bond
5.	NEI Contracting & Engineering 335 E Street, Suite B Chula Vista, CA 91910	\$3,625,751	1-6	Bond
6.	AMG & Associates, Inc. 28296 Constellation Road Santa Clarita, CA 91355	\$3,638,000	1-6	Bond
7.	SOL-PAC Construction, Inc. dba Soltek Pacific Construction Company 2424 Congress Street San Diego, CA 92110	\$3,742,000	1-6	Bond
8.	Cox Construction Co. 3170 Scott Street Vista, CA 92081	\$3,759,000	1-6	Bond
9.	T.B. Penick & Sons 15435 Innovation Drive, Suite 100 San Diego, CA 92128	\$3,900,000	1-6	Bond
10.	R. Clapper Construction Service, Inc. 2223 N. Locust Avenue Rialto, CA 92377	\$3,990,000	1-6	Bond
11.	I.E. Pacific Inc. 1663 Pacific Rim Ct. San Diego, CA 92154	\$4,129,000	1-6	Bond

National City Aquatic Center, Specification No. 13-04

Item No.	Description	Unit	Qty.	Precise Construction Management	Watkins Landmark Construction	EC Constructors
				Unit Price	Unit Price	Unit Price
BASE BID						
1	Construction of the new Aquatic Center and all site and off-site improvements and utilities complete and in-place as a turn-key project	LS	1	\$ 3,170,000.00	\$ 3,445,950.00	\$ 3,524,896.00

RESOLUTION NO. 2013 –

RESOLUTION OF THE CITY COUNCIL OF THE CITY OF NATIONAL CITY
AWARDING A CONTRACT TO EC CONSTRUCTORS, INC.,
IN THE NOT TO EXCEED AMOUNT OF \$3,524,896
FOR THE NATIONAL CITY AQUATIC CENTER PROJECT,
AUTHORIZING A 15% CONTINGENCY IN THE AMOUNT
OF \$528,734.40 FOR ANY UNFORESEEN CHANGES, AND
AUTHORIZING THE MAYOR TO EXECUTE SAID CONTRACT

WHEREAS, the Engineering Division of the Development Services Department, in open session on August 20, 2013, did publicly open, examine, and declare 11 sealed bids for the National City Aquatic Center Project ("Project"); and

WHEREAS, Precise Construction Management was the apparent low bidder with a total bid amount of \$3,170,000.00, but due to a clerical error, Precise Construction Management withdrew their bid; and

WHEREAS, Watkins Landmark Construction was the second apparent low bidder with a total bid amount of \$3,445,950.00, however, their bid was deemed "non-responsive"; and

WHEREAS, EC Constructors, Inc., was the third apparent low bidder with a total bid amount of \$3,524,896. Upon review of all documents submitted and reference checks, EC Constructors' bid is responsive, and they are the lowest responsible bidder qualified to perform the work as described in the project specifications; and

WHEREAS, a 15% contingency amount up to \$528,734.40 for any unforeseen changes to the Project is requested.

NOW, THEREFORE, BE IT RESOLVED that the City Council of the City of National City hereby awards the contract for the National City Aquatic Center Project to the lowest responsive, responsible bidder, to wit:

EC CONSTRUCTORS, INC.

BE IT FURTHER RESOLVED by the City Council of the City of National City that the Mayor is hereby authorized to execute on behalf of the City a contract in the amount of \$3,524,896 with EC Constructors, Inc., for the National City Aquatic Center Project. Said contract is on file in the office of the City Clerk.

PASSED and ADOPTED this 17th day of September, 2013.

Ron Morrison, Mayor

ATTEST:

APPROVED AS TO FORM:

Michael R. Dalla, City Clerk

Claudia Gacitua Silva
City Attorney

**CITY OF NATIONAL CITY, CALIFORNIA
COUNCIL AGENDA STATEMENT**

MEETING DATE: September 17, 2013

AGENDA ITEM NO.

ITEM TITLE:

Resolution of the City Council of the City of National City authorizing the Mayor to execute an Encroachment Permit and Agreement between the City of National City and Nagraj, Inc. (APN 557-410-19), whereby the City grants an aerial encroachment over a portion of public right of way located at 1700 E. Plaza Boulevard

PREPARED BY: Stephen Manganiello

DEPARTMENT: Engineering

PHONE: 336-4382

APPROVED BY: _____

EXPLANATION:

See attached.

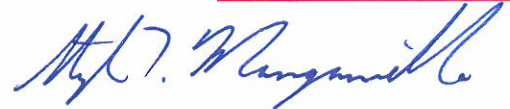

FINANCIAL STATEMENT:

APPROVED: _____ **Finance**

ACCOUNT NO.

APPROVED: _____ **MIS**

N/A

ENVIRONMENTAL REVIEW:

N/A

ORDINANCE: INTRODUCTION:

FINAL ADOPTION:

STAFF RECOMMENDATION:

Adopt the Resolution.

BOARD / COMMISSION RECOMMENDATION:

N/A

ATTACHMENTS:

1. Explanation
2. Encroachment Permit and Agreement with Exhibits
3. Resolution

EXPLANATION

On November 15, 2011, City Council adopted Resolution No. 2011-248, which amended Resolution No. 2010-59 (adopted on April 6, 2010) finding and declaring the public interest and necessity for acquiring and authorizing condemnation and possession of certain real property interests for municipal purposes for the Plaza Boulevard Widening Project.

On or about June 29, 2010, the City filed its complaint in Eminent Domain in the San Diego County Superior Court, Case No. 2010-00077984-CU-EI-SC, titled *City of National City v. Nagraj, Inc., et al.* to acquire portions of Assessors Parcel No. 557-410-19. The Court subsequently allowed the filing of a Second Amended Complaint in Eminent Domain which was required due to the time extension of the Temporary Construction Easement (TCE) for said parcel. See attached Exhibit "A" for legal descriptions and parcel map reflecting permanent property acquisition and TCE for APN 557-410-19.

As a result of the right of way acquisition, a portion of the sign owned by Nagraj, Inc. will partially extend over the public right of way. Therefore, staff recommends granting an aerial encroachment as defined in attached Exhibit "B". The encroachment permit and agreement requires a minimum ground clearance of seven feet to maintain ADA requirements along the sidewalk.

ENCROACHMENT PERMIT AND AGREEMENT
(Commercial)

The City Of National City hereby grants an Encroachment Permit to the undersigned, (hereinafter referred to as "OWNER") in accordance with and pursuant to the terms and conditions set forth in Chapter 13.12 of the National City Municipal Code, expressly incorporated herein by reference.

OWNER is the owner of that certain real property described in the attached Exhibit "A", or is an owner of personal property that is proposed to be installed in the public right of way or other public property of the City of National City, County of San Diego, State of California as a result of the project ("Project") described in Exhibit A2 of the Second Amended Complaint in that civil action entitled *City of National City, etc. v. Nagraj, Inc, et al.* being San Diego County Superior Court case number 37-2010-00077984-CU-EI-SC. The OWNER, in consideration of this grant of permission by the City of National City (hereinafter referred to as "CITY") to maintain certain personal property or a building, facility or other structure (hereafter designated from time to time as an "encroachment") within or upon a CITY easement, property or right-of-way for the use and benefit of OWNER'S property and adjacent lands, now covenants and agrees as follows:

The site of installation and any description of OWNER'S encroachment are described in EXHIBIT B, attached hereto and made a part hereof.

The terms and conditions under which the encroachment is to be installed and maintained upon completion of the Project are as follows:

1. As set forth hereinbelow, upon revocation by CITY, through its City Engineer, the above described encroachment shall be abandoned, removed or relocated by OWNER at the OWNER'S sole expense. The City Engineer may revoke this encroachment permit for cause upon determining that OWNER is proceeding in a hazardous manner, has failed to comply with one or more of the material terms, conditions or restrictions incorporated in the permit; or has provided materially false or misleading information to the City Engineer regarding the encroachment or its installation. The City Engineer may also revoke this encroachment permit without cause when necessary to remove the encroachment extending onto public property from private property that interferes with public convenience, welfare and/or safety. In circumstances involving public convenience, welfare and/or safety, CITY shall first give OWNER notice of any interference and allow OWNER thirty (30) days to remedy said condition (if feasible) before removal is mandated. CITY shall provide details in the notice to OWNER with sufficient specificity to allow OWNER to correct such interference. If the condition cannot be remediated, OWNER must remove the encroachment. The terms of this section 1 control over Section 13.12.080(A) of the Municipal Code. However, nothing in this section 1 shall prohibit the CITY from taking any action deemed necessary by the City Engineer to protect the public convenience, welfare and/or safety from the encroachment, the reasonable costs of which shall be paid by the OWNER. Nothing in this section 1 shall limit the appeal rights of the OWNER as set forth in Section 13.12.110 of the Municipal Code.

2. After completion of the Project at the property of the OWNER, said encroachment shall be maintained in a safe and sanitary condition at all times at the sole cost, risk and responsibility of OWNER and any successor in interest, who shall hold CITY harmless with respect thereto.

3. This permit and agreement, when made for the direct benefit of OWNER'S land or property above described, and the covenants herein contained shall run with said land and shall be binding on the assigns and successors of OWNER. Should OWNER or its successors fail to remedy, remove or relocate the encroachment herein permitted within thirty (30) days after notice of removal or relocation from the City, CITY may cause such removal or relocation to be done at OWNER'S sole cost and expense. A copy of this encroachment agreement shall be recorded against any real property of the OWNER'S that is hereby

benefited by the encroachment. Upon request by CITY, OWNER shall record this Encroachment Agreement with the County of San Diego, County Recorder's Office, and upon recordation shall return the original to the CITY.

4. After completion of the Project at the property of the OWNER, OWNER shall indemnify, defend, and hold harmless CITY and its officers, agents, and employees from all liability, loss, costs, claims, demand, suits, and defense costs, including attorneys' fees, arising out of OWNER'S entry upon and use of CITY'S easement or right-of-way for the installation, maintenance, and use of the OWNER'S encroachment.

5. OWNER and each successor in interest or assign shall take out and maintain, during the time the encroachment remains on CITY'S easement or right-of-way, comprehensive general liability insurance with minimum limits of One Million Dollars (\$1,000,000.00) combined single limit per occurrence, covering all bodily and property damage arising out of this Agreement.

This policy shall name CITY and its officers, agents, and employees as additional insured, and shall constitute primary insurance as to CITY and its officers, agents and employees, so that any other policies held by CITY shall not contribute to any loss under said insurance. Said policy shall provide for thirty (30) days prior written notice to CITY of cancellation or material change. Prior to commencement of this Agreement, OWNER shall furnish CITY a certificate of insurance with original endorsements evidencing the coverage required by this clause. Should owner fail to do so, CITY may elect to obtain such coverage at OWNER'S expense or immediately terminate this agreement.

6. The full terms and conditions under which, this encroachment permit is issued are further set forth in Chapter 13.12 of the National City Municipal Code, which terms OWNER hereby specifically acknowledges and agrees to which owner.

7. This encroachment Permit is not valid and confers no rights to install and maintain an encroachment until it is accepted by both the OWNER and CITY.

DATED:
CITY OF NATIONAL CITY

OWNER:

Ron Morrison, Mayor

NAVRAT INC DBA Standard Firm
Entity/Company

Signature

CEO
Name & Title

ATTACH NOTARY CERTIFICATION FOR THE NAME OF PERMITTE SHOWN ABOVE.
USE CALIFORNIA ALL PURPOSE ACKNWLEGEEMENT NOTARY ONLY.

NAORAJ INC

OWNER/APPLICANT INFORMATION:

MUKESH JARIWALA
Person in Responsible Charge

Mailing Address:

619 474 6491
24/7 Phone Number

1700 E PLAZA BLVD

NATIONAL CITY CA 91950

Standard IN
Firm Name

PLAT SHOWING LOCATION OF STRUCTURES, EASEMENT, OR RIGHT-OF-WAY, AND SEWER AND/OR DRAINAGE FACILITIES: SEE EXHIBIT "B", ATTACHED

EXHIBIT "A"

PERMANENT ACQUISITION
APN 557-410-19

THAT PORTION OF THE NORTHWESTERLY QUARTER OF THE WESTERLY HALF OF 80.00 ACRE LOT 2 IN QUARTER SECTION 129 OF RANCHO DE LA NACION, IN THE CITY OF NATIONAL CITY, COUNTY OF SAN DIEGO, STATE OF CALIFORNIA, ACCORDING TO MAP THEREOF NO. 166, FILED IN THE OFFICE OF THE COUNTY RECORDER OF SAN DIEGO COUNTY, MAY 11, 1869, MORE PARTICULARLY DESCRIBED AS FOLLOWS:

BEGINNING AT A BRASS DISK STAMPED CP5 ACCORDING TO RECORD OF SURVEY MAP NO. 17515 FILED IN THE OFFICE OF THE COUNTY RECORDER ON AUGUST 30, 2002 WHICH BEARS SOUTH 17°35'27" EAST 285.74 FEET FROM A BRASS DISK STAMPED CP6 ACCORDING TO SAID RECORD OF SURVEY MAP; THENCE NORTH 89°04'36" EAST 383.63 FEET TO A POINT IN THE WESTERLY LINE OF LAND PER DEED RECORDED MARCH 13, 1998 AS DOCUMENT NO. 1998-0138180 OF OFFICIAL RECORDS, SAID POINT BEING THE TRUE POINT OF BEGINNING;

1. THENCE ALONG SAID WESTERLY LINE NORTH 17°41'47" WEST 7.45 FEET TO THE NORTHWEST CORNER OF SAID LAND AND THE BEGINNING OF A NON-TANGENT 540.00-FOOT RADIUS CURVE CONCAVE NORTHERLY, A RADIAL LINE TO SAID POINT BEARS SOUTH 12°05'11" WEST, SAID POINT BEING ON THE SOUTHERLY LINE OF PLAZA BOULEVARD;
2. THENCE ALONG THE NORTHERLY LINE OF SAID PARCEL EASTERLY ALONG THE ARC OF SAID CURVE THROUGH A CENTRAL ANGLE OF 16°03'56" A DISTANCE OF 151.41 FEET TO THE NORTHEAST CORNER OF SAID LAND, A RADIAL LINE TO SAID POINT BEARS SOUTH 3°58'45" EAST (SOUTH 4°24'17" EAST PER SAID DEED)
3. THENCE LEAVING SAID NORTHERLY LINE ALONG THE EASTERLY LINE OF LAND PER SAID DEED SOUTH 17°41'47" EAST 2.61 FEET TO THE BEGINNING OF A NON-TANGENT 612.20-FOOT RADIUS CURVE CONCAVE NORTHERLY, A RADIAL LINE TO SAID POINT BEARS SOUTH 4°40'21" EAST;
4. THENCE LEAVING SAID EASTERLY LINE WESTERLY ALONG THE ARC OF SAID CURVE THROUGH A CENTRAL ANGLE OF 13°59'51" A DISTANCE OF 149.56 FEET TO THE TRUE POINT OF BEGINNING.

AREA = 0.014 ACRES, MORE OR LESS.

Mickey B. Aguirre 5-22-08
MICKEY B. AGUIRRE RCE 27648
EXP: 3-31-10



EXHIBIT "A"

TEMPORARY CONSTRUCTION EASEMENT APN 557-410-19

THAT PORTION OF THE NORTHWESTERLY QUARTER OF THE WESTERLY HALF OF 80.00 ACRE LOT 2 IN QUARTER SECTION 129 OF RANCHO DE LA NACION, IN THE CITY OF NATIONAL CITY, COUNTY OF SAN DIEGO, STATE OF CALIFORNIA, ACCORDING TO MAP THEREOF NO. 166, FILED IN THE OFFICE OF THE COUNTY RECORDER OF SAN DIEGO COUNTY, MAY 11, 1869, MORE PARTICULARLY DESCRIBED AS FOLLOWS:

BEGINNING AT A BRASS DISK STAMPED CP5 ACCORDING TO RECORD OF SURVEY MAP NO. 17515 FILED IN THE OFFICE OF THE COUNTY RECORDER ON AUGUST 30, 2002 WHICH BEARS SOUTH 17°35'27" EAST 285.74 FEET FROM A BRASS DISK STAMPED CP6 ACCORDING TO SAID RECORD OF SURVEY MAP; THENCE NORTH 89°04'36" EAST 383.63 FEET TO A POINT IN THE WESTERLY LINE OF LAND PER DEED RECORDED MARCH 13, 1998 AS DOCUMENT NO. 1998-0138180 OF OFFICIAL RECORDS AND THE BEGINNING OF A NON-TANGENT 612.20-FOOT RADIUS CURVE CONCAVE NORTHERLY, A RADIAL LINE TO SAID POINT BEARS SOUTH 9°19'30" WEST, SAID POINT BEING THE TRUE POINT OF BEGINNING;

1. THENCE LEAVING SAID WESTERLY LINE EASTERLY ALONG THE ARC OF SAID CURVE THROUGH A CENTRAL ANGLE OF 13°59'51" A DISTANCE OF 149.56 FEET TO A POINT ON THE EASTERLY LINE OF LAND PER SAID DEED;
2. THENCE ALONG SAID EASTERLY LINE SOUTH 17°41'47" EAST (SOUTH 18°13'32" EAST PER SAID DEED) 10.26 FEET TO THE BEGINNING OF A NON-TANGENT 622.20-FOOT RADIUS CURVE CONCAVE NORTHERLY, A RADIAL LINE TO SAID POINT BEARS SOUTH 4°53'08" EAST;
3. THENCE LEAVING SAID EASTERLY LINE WESTERLY ALONG THE ARC OF SAID CURVE THROUGH A CENTRAL ANGLE OF 3°30'27" A DISTANCE OF 38.09 FEET;
4. THENCE SOUTH 0°49'41" WEST 4.00 FEET TO THE BEGINNING OF A NON-TANGENT 626.20-FOOT RADIUS CURVE CONCAVE NORTHERLY, A RADIAL LINE TO SAID POINT BEARS SOUTH 1°21'50" EAST;
5. THENCE WESTERLY ALONG THE ARC OF SAID CURVE THROUGH A CENTRAL ANGLE OF 4°25'08" A DISTANCE OF 48.30 FEET;
6. THENCE NORTH 9°40'39" EAST 4.03 FEET TO THE BEGINNING OF A NON-TANGENT 622.20-FOOT RADIUS CURVE CONCAVE NORTHERLY, A RADIAL LINE TO SAID POINT BEARS SOUTH 3°00'44" WEST;
7. THENCE WESTERLY ALONG THE ARC OF SAID CURVE THROUGH A CENTRAL ANGLE OF 5°50'39" A DISTANCE OF 63.46 FEET TO A POINT ON THE WESTERLY LINE OF LAND PER SAID DEED;
8. THENCE ALONG SAID WESTERLY LINE NORTH 17°41'47" WEST 11.20 FEET TO THE TRUE POINT OF BEGINNING.

EXHIBIT "A"

(Page 2)

AREA = 0.039 ACRES, MORE OR LESS.



Mickey B. Aguirre 5-22-06
MICKEY B. AGUIRRE RCE 27648
EXP. 3-31-10

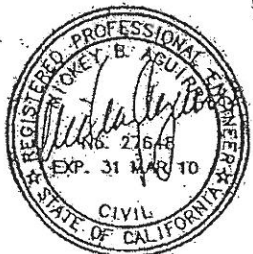
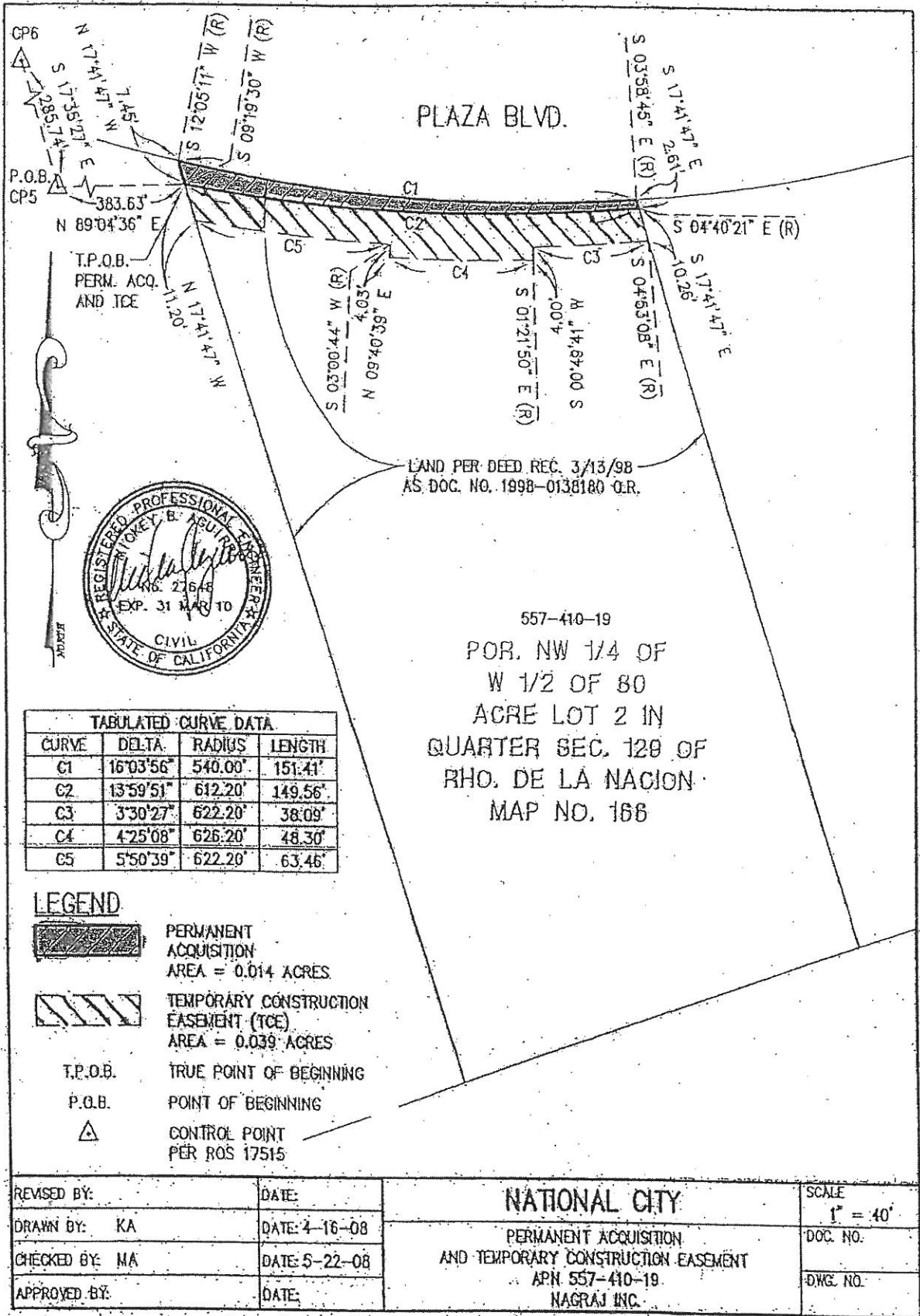

EXHIBIT "A"

APN 557-410-19



TABULATED CURVE DATA			
CURVE	DELTA	RADIUS	LENGTH
C1	16°03'56"	540.00'	151.41'
C2	13°59'51"	612.20'	149.56'
C3	3°30'27"	622.20'	38.09'
C4	4°25'08"	626.20'	48.30'
C5	5°50'39"	622.20'	63.46'

LEGEND

-  PERMANENT ACQUISITION
AREA = 0.014 ACRES
-  TEMPORARY CONSTRUCTION EASEMENT (TCE)
AREA = 0.039 ACRES
- T.P.O.B. TRUE POINT OF BEGINNING
- P.O.B. POINT OF BEGINNING
-  CONTROL POINT
PER ROS 17515

REVISED BY:	DATE:	NATIONAL CITY PERMANENT ACQUISITION AND TEMPORARY CONSTRUCTION EASEMENT APN 557-410-19 NAGRAJ INC.	SCALE 1" = 40'
DRAWN BY: KA	DATE: 4-16-08		DOC. NO.
CHECKED BY: MA	DATE: 5-22-08		DWG. NO.
APPROVED BY:	DATE:		

EXHIBIT "B"
AERIAL ENCROACHMENT AREA
APN 557-410-19

AN AERIAL ENCROACHMENT FOR A SIGN HEAD WITH A MINIMUM VERTICAL CLEARANCE OF SEVEN FEET AS MEASURED FROM THE FINISH SURFACE OF THE SIDEWALK TO THE BOTTOM OF THE SIGN HEAD AND A MAXIMUM VERTICAL ALLOWANCE OF FORTY FEET TO THE TOP OF THE SIGN ENCROACHING OVER A PORTION OF EAST PLAZA BOULEVARD BEING A PORTION OF THE NORTHWESTERLY QUARTER OF THE WESTERLY HALF OF 80 ACRE LOT 2 IN QUARTER SECTION 129 OF RANCHO DE LA NACION, IN THE CITY OF NATIONAL CITY, COUNTY OF SAN DIEGO, STATE OF CALIFORNIA ACCORDING TO THE MAP THEREOF NO. 166, FILED IN THE OFFICE OF THE COUNTY RECORDER OF SAN DIEGO COUNTY, MAY 11, 1869 MORE PARTICULARLY DESCRIBED AS FOLLOWS:

COMMENCING AT A BRASS DISK STAMPED CP5 ACCORDING TO RECORD OF SURVEY MAP NO. 17515 FILED IN THE OFFICE OF THE COUNTY RECORDER ON AUGUST 30, 2002 WHICH BEARS SOUTH 17°35'27" EAST FROM A BRASS DISK STAMPED CP6 ACCORDING TO SAID RECORD OF SURVEY MAP THENCE NORTH 89°04'36" EAST A DISTANCE OF 383.63' TO A POINT IN THE WESTERLY LINE OF LAND CONVEYED PER DEED RECORDED MARCH 13, 1998 AS DOCUMENT NUMBER 1998-0138180 OF OFFICIAL RECORDS SAID POINT BEING THE BEGINNING OF A NON-TANGENT 612.20 FOOT RADIUS CURVE CONCAVE NORTHERLY, A RADIAL LINE TO SAID POINT BEARS SOUTH 9°19'30" WEST

THENCE EASTERLY ALONG THE ARC OF SAID CURVE THROUGH A CENTRAL ANGLE OF 1°26'38" A DISTANCE OF 15.430 FEET TO A POINT IN SAID CURVE, A RADIAL LINE TO SAID POINT BEARS SOUTH 7°52'52" WEST SAID POINT ALSO BEING THE TRUE POINT OF BEGINNING;

THENCE LEAVING SAID CURVE NORTH 07°52'52" EAST A DISTANCE OF 5.875 FEET TO A POINT ON A NON-TANGENT 540 FOOT RADIAL CURVE CONCAVE NORTHERLY, A RADIAL LINE TO SAID POINT BEARS SOUTH 10°14'19" WEST, SAID POINT BEING ON THE SOUTHERLY LINE OF PLAZA BOULEVARD;

THENCE ALONG THE SOUTHERLY LINE OF PLAZA BOULEVARD EASTERLY ALONG THE ARC OF SAID CURVE THROUGH A CENTRAL ANGLE OF 0°21'36" A DISTANCE OF 3.00 FEET, A RADIAL LINE TO SAID POINT BEARS SOUTH 10°02'58" WEST;

THENCE LEAVING THE SOUTHERLY LINE OF PLAZA BOULEVARD SOUTH 7°52'52" WEST A DISTANCE OF 5.752 FEET TO A POINT ON SAID NON-TANGENT 612.20 FOOT RADIAL CURVE CONCAVE NORTHERLY, A RADIAL LINE TO SAID POINT BEARS SOUTH 7°34'12" WEST;

THENCE WESTERLY ALONG THE ARC OF SAID CURVE A CENTRAL ANGLE OF 0°18'40" A DISTANCE OF 3.00 FEET TO THE TRUE POINT OF BEGINNING.

AREA=17.4282 SQUARE FEET MORE OR LESS.

NATIONAL CITY
ENCROACHMENT AGREEMENT
AGREEMENT DATE
ENGINEERING NO.

EXHIBIT "B"

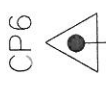
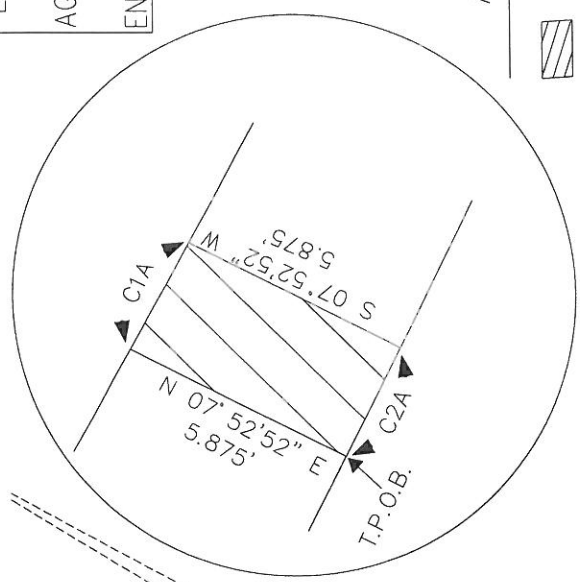
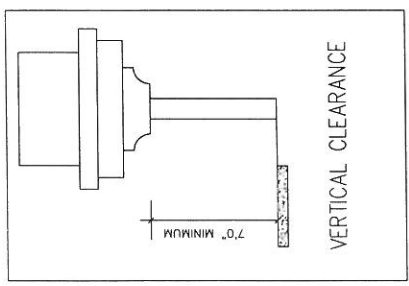

S17° 35' 27" E
285.74'

N89° 04' 36" E
383.63'
CP5
P.O.B.

S 12° 05' 11" W 15.43'
S 09° 19' 30" W 12.0511'

TABULATED CURVE DATA

CURVE	DELTA	RADIUS	LENGTH
C1	16° 03' 56"	540.00'	151.41'
C1A	02° 21' 36"	540.00'	3.00'
C2	13° 59' 51"	612.20'	149.55'
C2A	0° 18' 40"	612.20'	3.00'

LEGEND

- ENCROACHMENT AREA
- CONTROL POINT PER ROS 17515
- P.O.B. POINT OF BEGINNING
- T.P.O.B. TRUE POINT OF BEGINNING

DETAIL "A"

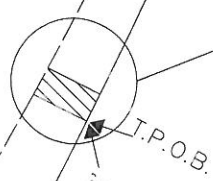

SEE DETAIL "A"
THIS SHEET

BOUNDARY OF LAND PER DEED
RECORDED 3/13/98 AS DOC.
NO. 1998-0138180 O.R.

APN 557 410 19

RESOLUTION NO. 2013 –

RESOLUTION OF THE CITY COUNCIL OF THE CITY OF NATIONAL CITY
AUTHORIZING THE MAYOR TO EXECUTE AN ENCROACHMENT PERMIT AND
AGREEMENT BY AND BETWEEN THE CITY OF NATIONAL CITY AND NAGRAJ, INC.,
WHEREBY THE CITY GRANTS AN AERIAL ENCROACHMENT OVER A PORTION OF
PUBLIC RIGHT-OF-WAY LOCATED AT 1700 EAST PLAZA BOULEVARD

WHEREAS, on November 15, 2011, the City Council adopted Resolution No. 2011-248, which amended Resolution No. 2010-59 (adopted on April 6, 2010) finding and declaring the public interest and necessity for acquiring and authorizing condemnation and possession of certain real property interests for municipal purposes for the Plaza Boulevard Widening Project; and

WHEREAS, on or about June 29, 2010, the City filed its complaint in Eminent Domain in the San Diego County Superior Court, Case No. 2010-00077984-CU-EI-SC, titled *City of National City v. Nagraj, Inc., et al.* to acquire portions of Assessor's Parcel No. 557-410-19. The Court subsequently allowed the filing of a Second Amended Complaint in Eminent Domain which was required due to the time extension of the Temporary Construction Easement (TCE) for said parcel; and

WHEREAS, because of the right-of-way acquisition, a portion of the sign owned by Nagraj, Inc., located at 1700 East Plaza Boulevard will partially extend over the public right-of-way, Nagraj, Inc., has submitted an Encroachment Permit and Agreement for an aerial encroachment that requires a minimum ground clearance of seven feet to maintain ADA requirements along the sidewalk.

NOW, THEREFORE, BE IT RESOLVED that the City Council of the City of National City hereby approves and authorizes the Mayor to execute an Encroachment Permit and Agreement with Nagraj, Inc., granting an aerial encroachment over a portion of public right-of-way at 1700 East Plaza Boulevard. Said Agreement is on file in the office of the City Clerk.

PASSED and ADOPTED this 17th day of September, 2013.

Ron Morrison, Mayor

ATTEST:

Michael R. Dalla, City Clerk

APPROVED AS TO FORM:

Claudia Gacitua Silva
City Attorney

**CITY OF NATIONAL CITY, CALIFORNIA
COUNCIL AGENDA STATEMENT**

MEETING DATE: September 17, 2013

AGENDA ITEM NO. |

ITEM TITLE:

Resolution of the City Council of the City of National City authorizing the Mayor to sign an Indemnity Agreement relating to Fire/Police training operations, by and between the City of National City and Costco Wholesale Corporation, Owners of the Property at 1001 West 19th Street, National City, CA 91950 for training purposes for Police and Fire personnel in a vacant structure. (Fire)

PREPARED BY: Walter Amedee

DEPARTMENT: Fire

PHONE: 619-336-4556

APPROVED BY: _____

EXPLANATION:

The Costco Wholesale Corporation has decided to demolish the building and plans to build a new structure located at 1001 West 19th Street. This vacant structure provides a training opportunity for police and fire personnel to perform "real life" training such as ventilation maneuvers, SWAT activities, and the like. The training would not include any burning of the structures. The Costco Wholesale Corporation has agreed to allow the National City Fire Department and Police Department to use the property, free of charge. The City agrees to be responsible for all training operations and any consequential injury or damage to persons during the training operations. The Costco Wholesale Corporation will be responsible for assuring that all persons are vacated from such premises immediately prior to the training operations, will disclose any known dangerous or hazardous conditions on or of the property, and will confirm with City that the training operations have concluded prior to authorizing any demolition of the property. Notification will be provided to residents and businesses. The Costco Wholesale Corporation agrees to indemnify, hold harmless and release the City from liability concerning the training operations.

FINANCIAL STATEMENT:

APPROVED: _____ **Finance**

ACCOUNT NO. |

APPROVED: _____ **MIS**

No financial impact.

ENVIRONMENTAL REVIEW:

|

ORDINANCE: INTRODUCTION: FINAL ADOPTION:

STAFF RECOMMENDATION:

Authorize the Mayor to sign an Indemnity Agreement and Release by and between the City of National City and the Costco Wholesale Corporation, Owners of the Property at 1001 West 19th Street for police and fire training.

BOARD / COMMISSION RECOMMENDATION:

|

ATTACHMENTS:

1. Indemnity Agreement relating to Fire/Police training operations, by and between the City of National City and Costco Wholesale Corporation
2. Resolution

**INDEMNITY AGREEMENT RELATING TO
FIRE AND POLICE TRAINING OPERATIONS,
BY AND BETWEEN THE CITY OF NATIONAL CITY
AND COSTCO WHOLESALE CORPORATION**

THIS INDEMNITY AGREEMENT ("Agreement") is entered into this 17th day of September, 2013, by and between the CITY OF NATIONAL CITY, a municipal corporation ("CITY") and COSTCO WHOLESALE CORPORATION ("OWNER"), owner of the property located at 1001 West 19th Street (the "PROPERTY"), collectively referred to as the "PARTIES".

R E C I T A L S

WHEREAS, the City of National City Fire Department desires the opportunity to participate in ventilation maneuvers and training operations in a vacant structure; and

WHEREAS, the City of National City Police Department desires the opportunity to participate in SWAT training maneuvers and operations in a vacant structure; and

WHEREAS, the OWNER will be demolishing a structure located at the Property; and

WHEREAS, the CITY has requested permission from the OWNER to use the Property, prior to scheduled demolition of the structure, for the CITY Fire Department to perform ventilation maneuvers and training operations (which would not include any burning of the Property or structure) and for the CITY Police Department to perform SWAT training activities and operations (collectively referred to as "Training Operations"); and

WHEREAS, OWNER desires to cooperate with the CITY and to authorize Training Operations at the Property, subject to the terms and conditions set forth herein.

NOW, THEREFORE, THE PARTIES HERETO DO MUTUALLY AGREE AS FOLLOWS:

1. The OWNER hereby agrees to allow the CITY to use the Property, free of charge, to conduct Training Operations on or about September _____, 2013.

2. The CITY acknowledges and agrees that the Training Operations are a hazardous activity that are being conducted for the CITY's own benefit. The CITY therefore agrees to assume all risk and accept full responsibility and liability for the Training Operations, including sole responsibility for: (a) inspecting the Property for potentially hazardous conditions, whether known or unknown, that could in any way

affect the Training Operations and issues of health or safety relating thereto; (b) all safety and risk of injury or damage in connection with the Training Operations; (c) the security of all persons and property potentially affected by the Training Operations; (d) complying with all applicable laws in relation to the Training Operations; and (d) all Claims (defined below) which could potentially result or arise from the Training Operations.

3. INDEMNIFICATION BY THE CITY. The CITY shall defend (with counsel of OWNER's choice), protect, indemnify and hold harmless OWNER and its general contractor, W. L. Butler Construction, Inc., and their respective agents, employees, affiliates, successors and assigns, and each of them ("Indemnitees") from and against any and all claims, demands, causes of action, damages, costs, expenses, actual attorneys' fees, losses and/or liabilities of every kind and nature whatsoever ("Claims") arising out of, relating to or in connection with the Training Operations, including, but not limited to, personal injury claims, property damage claims (to property other than the Property agreed as being subjected to the Training Operations), workers' compensation claims, and any other Claims arising from the Training Operations, except to the extent the Claims are caused by the sole negligence or willful misconduct of Indemnitees.

4. SIGNATURE AUTHORITY. The undersigned represent that they are authorized to sign this Agreement and to bind the Parties herein to this Agreement.

5. MISCELLANEOUS PROVISIONS.

A. *Applicable Law/Jurisdiction.* This Agreement shall be governed by and construed in accordance with the laws of the State of California. Jurisdiction over any dispute or claims arising from this Agreement shall be in the Superior Court of California in Orange County.

B. *Counterparts.* This Agreement may be executed in multiple counterparts, each of which shall be deemed an original, but all of which, together, shall constitute but one and the same instrument.

C. *Amendment to this Agreement.* The terms of this Agreement may not be modified or amended except by an instrument in writing executed by each of the Parties hereto.

D. *Waiver.* The waiver or failure to enforce any provision of this Agreement shall not operate as a waiver of any future breach of any such provision or any other provision hereof.

E. *Entire Agreement.* This Agreement supersedes any prior agreements, negotiations and communications, oral or written, and contains the entire agreement between the Parties as to the subject matter hereof. No subsequent agreement, representation, or promise made by either Party hereto, or by or to an

employee, officer, agent or representative of any Party hereto shall be of any effect unless it is in writing and executed by the Party to be bound thereby.

F. *Successors and Assigns.* This Agreement shall be binding upon and shall inure to the benefit of the successors and assigns of the Parties hereto.

IN WITNESS WHEREOF, the Parties hereto have executed this Agreement on the date and year first above written.

CITY OF NATIONAL CITY

COSTCO WHOLESALE CORPORATION
(Signatures of TWO corporate officers required)

Ron Morrison, Mayor

(Name)

Date: September 17, 2013

(Title)

Date: _____

APPROVED AS TO FORM:

(Name)

Claudia Gacitua Silva
City Attorney

(Title)

Date: _____

RESOLUTION NO. 2013 –

RESOLUTION OF THE CITY COUNCIL OF THE CITY OF NATIONAL CITY
AUTHORIZING THE MAYOR TO EXECUTE AN INDEMNITY AGREEMENT
RELATING TO FIRE AND POLICE TRAINING OPERATIONS WITH
COSTCO WHOLESALE CORPORATION, OWNERS OF THE PROPERTY
LOCATED AT 1001 WEST 19TH STREET, FOR TRAINING PURPOSES
FOR FIRE AND POLICE PERSONNEL AT A VACANT STRUCTURE

WHEREAS, Costco Wholesale Corporation (“Costco”) has decided to demolish the building on their property located at 1001 West 19th Street, National City; and

WHEREAS, Costco has agreed to allow the National City Fire Department and Police Department to use the property free of charge for training purposes; and

WHEREAS, the Indemnity Agreement provides that the City shall be responsible for all training operations, any consequential injury or damage to persons during the training operations, and indemnify, hold harmless and release Costco from liability concerning the training operations; and

WHEREAS, Costco shall be responsible for assuring that all persons are vacated from the premises immediately prior to the training operations, will disclose any known dangerous conditions on or of the property, and will confirm with the City that the training operations have conclude prior to authorizing any demolition of property,

NOW, THEREFORE, BE IT RESOLVED that the City Council of the City of National City hereby authorizes the Mayor to execute an Indemnity Agreement Relating to Fire/Police Training Operations with Costco Wholesale Corporation for training operations by the National City Fire Department and Police Department at the vacant structure on Costco’s property located at 1001 West 19th Street, National City.

PASSED and ADOPTED this 17th day of September, 2013.

Ron Morrison, Mayor

ATTEST:

Michael R. Dalla, City Clerk

APPROVED AS TO FORM:

Claudia Gacitua Silva
City Attorney

**CITY OF NATIONAL CITY, CALIFORNIA
COUNCIL AGENDA STATEMENT**

MEETING DATE: September 17, 2013

AGENDA ITEM NO.

ITEM TITLE:

National City Sales Tax Update Newsletter – First Quarter 2013

PREPARED BY: Mark Roberts, Director of Finance

DEPARTMENT: Finance

PHONE: 619-336-4265

APPROVED BY: Mark Roberts

EXPLANATION:

BACKGROUND

National City has an on-going contract with Hinderliter, de Llamas & Associates (HdL) for revenue management. Staff meets with a representative of HdL on a quarterly basis to review sales tax data and trends within the City and Statewide.

NEWSLETTER SUMMARY

Receipts for National City's January through March sales were 2.5% higher than the same quarter one year ago. Actual sales activity was up 3.7% when reporting aberrations were factored out. A recent addition helped boost sales for new auto dealers. Receipts from auto leases were skewed by onetime accounting adjustments in the year-ago period. The city experienced a strong sales quarter for several categories of general consumer goods. The gains were partially offset by a drop in sales for service stations, lumber/building materials, and contractors. A business relocation reduced receipts for light industrial/printers. The city's voter-approved Proposition D one cent transactions tax generated \$2,214,219 for a 2.1% gain over the same quarter a year ago. Adjusted for aberrations, taxable sales for all of San Diego County increased 6.1% over the comparable time period, while the Southern California region as a whole was up 6.5%.

FINANCIAL STATEMENT:

APPROVED: Mark Roberts Finance

ACCOUNT NO.

APPROVED: _____ MIS

NA

ENVIRONMENTAL REVIEW:

This is not a project and, therefore, not subject to environmental review.

ORDINANCE:

INTRODUCTION:

FINAL ADOPTION:

STAFF RECOMMENDATION:

Accept and file the newsletter.

BOARD / COMMISSION RECOMMENDATION:

ATTACHMENTS:

National City Sales Tax Update Newsletter – First Quarter 2013

Q1 2013



National City Sales Tax Update

Second Quarter Receipts for First Quarter Sales (January - March 2013)

National City In Brief

Receipts for National City's January through March sales were 2.5% higher than the same quarter one year ago. Actual sales activity was up 3.7% when reporting aberrations were factored out.

A recent addition helped boost sales for new auto dealers. Receipts from auto leases were skewed by onetime accounting adjustments in the year-ago period. The city experienced a strong sales quarter for several categories of general consumer goods.

The gains were partially offset by a drop in sales for service stations, lumber/building materials, and contractors. A business relocation reduced receipts for light industrial/printers.

The city's voter-approved Proposition D one-cent transactions tax generated \$2,214,219 for a 2.1% gain over the same quarter a year ago.

Adjusted for aberrations, taxable sales for all of San Diego County increased 6.1% over the comparable time period, while the Southern California region as a whole was up 6.5%.

SALES TAX BY MAJOR BUSINESS GROUP

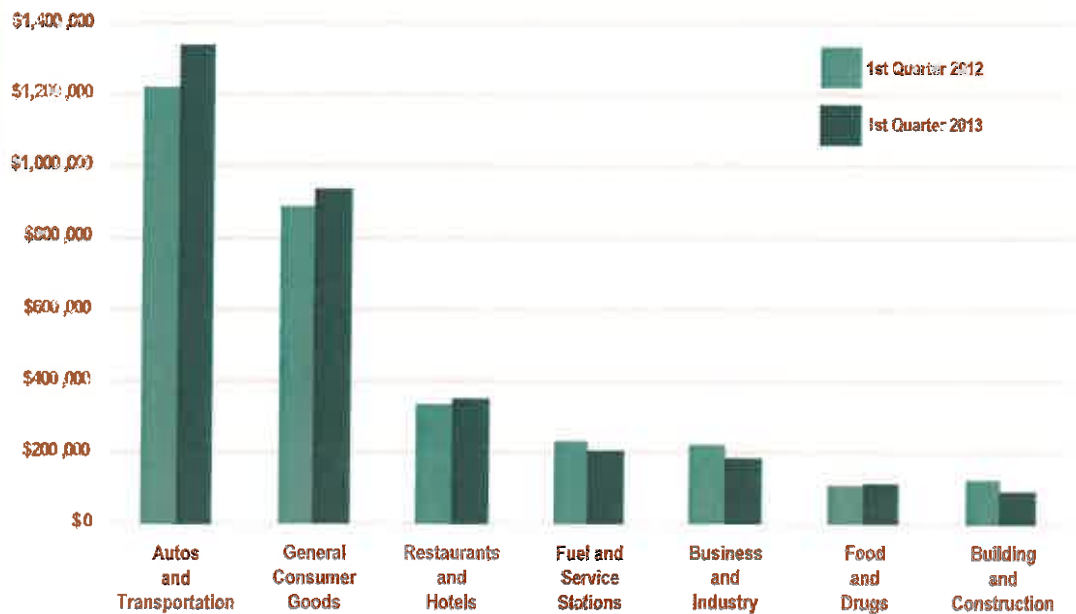

TOP 25 PRODUCERS

In Alphabetical Order

Arco AM PM	Perry Ford
Ball Honda Acura	Probuild Company
Mitsubishi Suzuki	Ron Baker Chevrolet
Kia	Ross
Frank Hyundai	South Bay
Frank Subaru	Volkswagen
Frank Toyota Scion	South County Buick
Highland Arco	GMC
JC Penney	Target
Macys	Tesoro Refining & Marketing
McCune Motors	Univar
Mor Furniture 4 Less	Vintners Distributors
Mossy Nissan	Walmart
Nordstrom Rack	Wescott Mazda
Perry Chrysler	
Dodge Jeep Ram	

REVENUE COMPARISON

Four Quarters - Fiscal Year To Date

	2011-12	2012-13
Point-of-Sale	\$12,126,222	\$13,068,292
County Pool	1,436,723	1,563,945
State Pool	4,415	6,860
Gross Receipts	\$13,567,361	\$14,639,097
Less Triple Flip*	\$(3,391,840)	\$(3,659,774)
Gross Trans. Tax	\$9,172,531	\$9,148,328

*Reimbursed from county compensation fund

California Overall

After adjusting for payment aberrations, statewide sales tax receipts for January through March sales were 6.5% higher than the same period in 2012.

Strong sales for apparel, department stores and big box discounters lifted general consumer goods and accounted for 23% of the statewide increase. Improvements in the housing sector pushed building and construction sales up 8.6%. Continued robust sales of new automobiles led to a 9.3% increase over the comparable quarter. Reduced consumption combined with lower gasoline prices cut fuel and service station returns in the first quarter by 2.7%.

Energy Projects Boost Business and Industry Gains

Taxes from construction of solar, wind, biomass and geothermal power projects accounted for 39% of California's business-to-business sales this quarter and produced significant windfalls for a handful of local agencies.

This temporary boost in revenues came from the federal government's goal of doubling the nation's renewable energy production in three years and from California's SB 2X which was signed in April of 2011 and calls for 33% of all retail electricity sales to be from renewable energy sources by 2020. Joint federal and state funding efforts to meet these goals have resulted in the initiation of more than a dozen utility-scale solar energy projects and over 130 renewable power plant projects in California.

Intermittent quarterly spikes in sales and use tax receipts from projects under construction or in the pipeline are expected for another two years.

Decline in Fuel Consumption Continues

According to the most recent data from the State Board of Equalization, California's gasoline usage fell 1.7% while diesel consumption eased 0.4% in the fourth quarter of 2012 from 2011 levels. This continues a decline that began in 2005 and which is almost twice the nationwide drop.

Historically, economic conditions have been the primary driver in fuel usage, however other factors are becoming increasingly prevalent. Nationally, total vehicle miles traveled have dropped eight years in a row as aging drivers travel fewer miles and the millennial generation, focused on social networking technology, is driving less than previous generations. Increased fuel efficiency is also at play with the average new car achieving 16% more miles per gallon than just five years ago and some

commercial trucking fleets shifting to natural gas.

Until recently, price increases have offset consumption declines. The price gains were partly the result of California refineries exporting their finished product to emerging economies with higher demand and also by periodic refinery and transmission interruptions in the state's limited production infrastructure.

SALES PER CAPITA

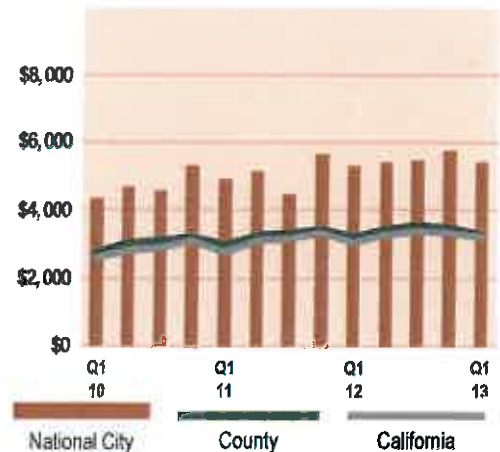

NATIONAL CITY TOP 15 BUSINESS TYPES

Business Type	National City		County	HdL State
	Q1 '13*	Change	Change	Change
Department Stores	138.0	3.5%	0.3%	5.1%
Discount Dept Stores	— CONFIDENTIAL —		5.2%	5.1%
Electronics/Appliance Stores	63.0	-2.2%	1.2%	-3.3%
Family Apparel	163.8	6.5%	16.2%	16.3%
Heavy Industrial	51.7	-4.6%	6.8%	7.8%
Home Furnishings	48.9	9.6%	4.7%	4.6%
Lumber/Building Materials	48.1	-18.0%	0.6%	7.2%
New Motor Vehicle Dealers	1,085.6	3.3%	6.9%	9.5%
Restaurants Liquor	54.5	3.6%	3.0%	6.4%
Restaurants No Alcohol	245.7	5.3%	8.6%	6.0%
Service Stations	206.6	-7.4%	2.4%	-2.2%
Shoe Stores	58.3	0.2%	7.8%	10.6%
Specialty Stores	83.7	20.0%	10.0%	2.4%
Used Automotive Dealers	89.0	10.6%	7.2%	7.9%
Women's Apparel	80.0	10.1%	11.4%	14.6%
Total All Accounts	\$3,221.8	2.8%	3.2%	5.7%
County & State Pool Allocation	396.4	-0.2%		
Gross Receipts	\$3,618.2	2.5%		<i>*In thousands</i>

CITY OF NATIONAL CITY, CALIFORNIA
COUNCIL AGENDA STATEMENT

MEETING DATE: September 17, 2013

AGENDA ITEM NO. |

ITEM TITLE:

Warrant Register #7 for the period of 8/7/13 through 8/13/13 in the amount of \$277,968.12. (Finance)

PREPARED BY: K. Apalategui

DEPARTMENT: Finance

PHONE: 619-336-4331

APPROVED BY: Mark Ralston

EXPLANATION:

Per Government Section Code 37208, attached are the warrants issued for the period of 8/7/13 through 8/13/13.

In accordance with Finance Department policy, below is an explanation of all warrants above \$50,000.00.

<u>Vendor</u>	<u>Check</u>	<u>Amount</u>	<u>Explanation</u>
Dixieline Builders	308633	58,421.00	Home Rehab Program 1140 E 2 nd Ave

FINANCIAL STATEMENT:

ACCOUNT NO. |

N/A

APPROVED: Mark Ralston

Finance

APPROVED: _____

MIS

ENVIRONMENTAL REVIEW:

This is not a project and, therefore, not subject to environmental review.

ORDINANCE: INTRODUCTION:

FINAL ADOPTION:

STAFF RECOMMENDATION:

Ratification of warrants in the amount of \$277,968.12

BOARD / COMMISSION RECOMMENDATION:

N/A

ATTACHMENTS:

Warrant Register #7



**WARRANT REGISTER # 7
8/13/2013**

<u>PAYEE</u>	<u>DESCRIPTION</u>	<u>CHK NO</u>	<u>DATE</u>	<u>AMOUNT</u>
3M LIBRARY SYSTEMS	MAINTENANCE / SELF-CHECK OUT / LIBRARY	308596	8/13/13	8,598.60
BAKER & TAYLOR	BOOKS -LIBRARY	308597	8/13/13	2,115.04
BRODART CO	BOOKS -LIBRARY	308598	8/13/13	1,278.48
GEISLER, H	STORYTELLING SHOW / LIBRARY	308599	8/13/13	200.00
MORRIS, J	PERFORMER FOR FAMILY LITERACY NIGHT	308600	8/13/13	225.00
LASER SAVER INC	MOP #45725 -INK CARTRIDGES	308601	8/13/13	147.04
MIDWEST TAPE	DVD'S / LIBRARY	308602	8/13/13	1,554.78
SPRINT	VIDEO CONFERENCING, LONG DISTANCE	308603	8/13/13	11.12
STAPLES ADVANTAGE	MOP # 45704 - SUPPLIES / LIBRARY	308604	8/13/13	405.78
U S POSTMASTER	POSTAGE FOR OVERDUE NOTICES	308605	8/13/13	276.00
XEROX CORPORATION	XEROX BASE CHARGES AND OVERAGES	308606	8/13/13	248.81
EDCO DISPOSAL CORPORATION	WASTE DISPOSAL SERVICES / S A	308607	8/13/13	110.23
SDG&E	GAS AND ELECTRIC UTILITIES / S A	308608	8/13/13	149.72
3M COMPANY	02429582 GLASSES - PROGRESSIVE	308609	8/13/13	338.04
ADORAMA CAMERA, INC.	SAMSUNG SERIES 5, SKU SSXE500T1C, ATIV,	308610	8/13/13	10,283.04
AHA HOUSING	MORTGAGE CREDIT CERTIFICATE PROGRAM	308611	8/13/13	2,231.00
AIRGAS WEST	MOP 45714 MATERIALS & SUPPLIES	308612	8/13/13	196.42
ALDEMCO	FOOD / NUTRITION CENTER	308613	8/13/13	2,484.18
ALL FRESH PRODUCTS	FOOD / NUTRITION CENTER	308614	8/13/13	3,036.90
AMERICAN BACKFLOW SPECIALTIES	BACKFLOWS, GAUGES, PARTS	308615	8/13/13	514.04
ARCO GASPRO PLUS	FUEL FOR CITY FLEET AS NEEDED FY 2014	308616	8/13/13	41,046.74
BOOT WORLD	MOP 64096 WEARING APPAREL	308617	8/13/13	356.90
BROADWAY AUTO ELECTRIC	MOP 72447 AUTO PARTS	308618	8/13/13	386.06
C A P F	FIRE/LTD AUG 2013	308619	8/13/13	576.00
CALIFORNIA ASSOCIATION OF	CACEO REGISTRATION / G IBARRA	308620	8/13/13	349.00
CALIFORNIA LAW ENFORCEMENT	PD/LTD AUG 2013	308621	8/13/13	1,984.50
CALPERS	ANNUAL BILLING FOR RETIREES	308622	8/13/13	12.15
CHRISTENSEN & SPATH LLP	LEGAL / SEC 8 WRIT MATTER	308623	8/13/13	35.00
CITY OF NATIONAL CITY	PETTY CASH REPLENISHMENT - JUNE 2013	308624	8/13/13	471.46
CITY OF NATIONAL CITY	PETTY CASH REPLENISHMENT - JULY 2013	308625	8/13/13	126.75
COMMUNITY HOUSING WORKS	ANNUAL SVC FEE 2012-2013	308626	8/13/13	11,000.00
DALEY & HEFT LLP	LIABILITY CLAIM COSTS	308627	8/13/13	3,349.90
DALLAS MIDWEST	90- STACK CHAIRS W/ ARMS 3" VINYL	308628	8/13/13	6,913.11
DANIELS TIRE SERVICE	TIRES	308629	8/13/13	575.65
DAY WIRELESS SYSTEMS (20)	COMMUNICATIONS EQUIPMENT SERVICE	308630	8/13/13	1,000.75
DE PASCALE, A	SUBSISTENCE: ASSAULT INVESTIGATION	308631	8/13/13	640.00
DELTA CARE USA	PMI DENTAL INS AUG 2013	308632	8/13/13	2,884.93
DIXIELINE BUILDERS	HOME REHAB PROGRAM/1140 E 2ND AVE	308633	8/13/13	58,421.00
DONNOE & ASSOCIATES INC	POLICE WRITING EXPERCISE - RENTAL FEE	308634	8/13/13	675.00
DREW FORD	MOP 49078 AUTO PARTS	308635	8/13/13	785.94
ERGOGENESIS LLC	ERGOGENESIS CHAIR MODEL 3607	308636	8/13/13	8,310.10
ERGOMETRICS	ENG LICENSE FOR TESTING	308637	8/13/13	576.17
FLEET SERVICES INC	MOP 67804 AUTO PARTS	308638	8/13/13	176.90
FUN FLICKS	MOVIE SCREEN 32FT FOR MOVIE IN THE PARK	308639	8/13/13	445.00
GLADWELL GOVT SERVICES INC	LEGAL REVIEW AND UPDATE OF RECORDS	308640	8/13/13	1,750.00
GOODYEAR TIRE & RUBBER COMPANY	TIRES	308641	8/13/13	325.88
GRANICUS INC	GRANICUS WEBCASTING / JUL 2013	308642	8/13/13	1,477.35
HAMILTON MEATS & PROVISIONS	MEAT DELIVERY SVCS / NUTRITION	308643	8/13/13	1,656.15
HEALTH NET	INS N5992A - AUG 2013	308644	8/13/13	1,575.21



**WARRANT REGISTER # 7
8/13/2013**

<u>PAYEE</u>	<u>DESCRIPTION</u>	<u>CHK NO</u>	<u>DATE</u>	<u>AMOUNT</u>
HEALTH NET INC	ACCT 57135J/N5992F - AUG 2013	308645	8/13/13	1,528.85
HOME DEPOT CREDIT SERVICES	POL CHRMPOP-UP LAVATORY ASSEMBLY	308646	8/13/13	438.71
HYDRO SCAPE PRODUCTS INC	MOP 45720 PIPES, VALVES, FITTINGS	308647	8/13/13	470.00
IBARRA, G	CACEO CODE ENFORCEMENT SEMINAR	308648	8/13/13	225.70
IEDA	ONLINE SURVEY SYSTEM FY 14	308649	8/13/13	1,389.00
IRON MOUNTAIN	RECORDS MANAGEMENT & STORAGE	308650	8/13/13	148.00
JJJ ENTERPRISES	ALARM MONITORING	308651	8/13/13	1,200.00
KAISER FOUNDATION HEALTH PLANS	RETIREE INS - AUG 2013	308652	8/13/13	21,523.82
LAKE TAHOE RESORT HOTEL	CACEO SEMINAR/ G IBARRA	308653	8/13/13	442.71
LOPEZ, T	TRANSLATION SERVICES FOR FY 2014	308654	8/13/13	140.00
MARCHANTE, A	REIMB - NOTARY COURSE	308655	8/13/13	65.00
MASON'S SAW &	MOP 45729 SMALL TOOLS	308656	8/13/13	672.48
MCAFFEE INC	EMAIL SPAM FILTERING/ARCHIVING	308657	8/13/13	10,890.00
MONOLOLO, M	EDUCATIONAL REIMBURSEMENT	308658	8/13/13	93.00
MOSSY NISSAN	2013 NISSAN ALTIMA / POLICE	308659	8/13/13	23,978.75
PADRE JANITORIAL SUPPLIES	JANITORIAL SUPPLIES / NUTRITION	308660	8/13/13	202.28
PERRY FORD	R&M CITY VEHICLES	308661	8/13/13	6,239.45
POWERSTRIDE BATTERY CO INC	MOP 67839 AUTO PARTS	308662	8/13/13	584.96
PRO-EDGE KNIFE	KNIFE SHARPENING SVCS / NUTRITION	308663	8/13/13	46.00
QUAL CHEM CORPORATION	Q229 ENZYME FOAM	308664	8/13/13	586.14
RIVERSIDE COUNTY SHERIFF DEPT	TUITION: ASSAULT INVESTIGATION	308665	8/13/13	113.00
ROUSTON, J	REIMB LICENSE	308666	8/13/13	140.00
ROUSTON, J	EDUCATIONAL REIMBURSEMENT	308667	8/13/13	140.00
SAN DIEGO UNION TRIBUNE	HEARING NOTICES	308668	8/13/13	615.20
SASI	PROCESSING CHARGES	308669	8/13/13	283.50
SDG&E	GAS & ELECTRIC SERVICE / NUTRITION	308670	8/13/13	2,056.46
SEAPORT MEAT COMPANY	FOOD / FOR NUTRITION	308671	8/13/13	2,107.45
SILVERADO AVIONICS	KENWOOD RADIO ANTENNA	308672	8/13/13	1,359.77
SMART SOURCE OF CA LLC	TR-130 NOTICE TO APPEAR CITATIONS	308673	8/13/13	1,897.94
SOUTH BAY MOTORSPORTS	R&M CITY VEHICLES	308674	8/13/13	354.29
SPARKLETTS	WATER FOR FY 2014	308675	8/13/13	11.46
STANLEY ACCESS TECHNOLOGIES	AUTOMATIC DOOR REPAIRS	308676	8/13/13	222.00
STAPLES ADVANTAGE	MOP 45704 OFFICE SUPPLIES - CITY MGR	308677	8/13/13	351.54
STEVENSON, S	ADVERTISING	308678	8/13/13	525.00
SWANK MOTION PICTURES INC	DVD ANGELS IN THE OUTFIELD LICENSE	308679	8/13/13	321.00
SWEETWATER AUTHORITY	PARKS WATER	308680	8/13/13	297.76
SYSCO SAN DIEGO	FOOD & CONSUMABLES / NUTRITION	308681	8/13/13	9,178.65
TODD PIPE & SUPPLY LLC	PLUMBING MATERIALS, PARTS	308682	8/13/13	1,976.87
U S BANK	CREDIT CARD EXP - CITY MGR	308684	8/13/13	853.16
UNION TRIBUNE	LEGAL NOTICES ADVERTISING / JUL 2013	308685	8/13/13	842.86
UNITED ROTARY BRUSH	STREET SWEEPER REPAIRS	308686	8/13/13	993.14
VALLEY INDUSTRIAL SPECIALTIES	MOP 46453 PLUMBING MATERIAL	308687	8/13/13	37.02
W W GRAINGER	MOP 65179 ELECTRICAL MATERIAL	308688	8/13/13	30.46
WESTFLEX INDUSTRIAL	MOP 63850 AUTO PARTS	308689	8/13/13	106.92

A/P Total **277,968.12**

GRAND TOTAL

\$ 277,968.12

Certification

IN ACCORDANCE WITH SECTION 37202, 37208, 372059 OF THE GOVERNMENT CODE, WE HEREBY CERTIFY TO THE ACCURACY OF THE DEMANDS LISTED ABOVE AND TO THE AVAILABILITY OF FUNDS FOR THE PAYMENT THEREOF AND FURTHER THAT THE ABOVE CLAIMS AND DEMANDS HAVE BEEN AUDITED AS REQUIRED BY LAW.



MARK ROBERTS, FINANCE

LESLIE DEESE, CITY MANAGER

FINANCE COMMITTEE

RONALD J. MORRISON, MAYOR-CHAIRMAN

LUIS NATIVIDAD, VICE-MAYOR

ALEJANDRA SOTELO-SOLIS, MEMBER

MONA RIOS, MEMBER

JERRY CANO, MEMBER

I HEREBY CERTIFY THAT THE FOREGOING CLAIMS AND DEMANDS WERE APPROVED AND THE CITY TREASURER IS AUTHORIZED TO ISSUE SAID WARRANTS IN PAYMENT THEREOF BY THE CITY COUNCIL ON THE 17th OF SEPTEMBER, 2013.

AYES _____

NAYS _____

ABSENT _____

CITY OF NATIONAL CITY, CALIFORNIA
COUNCIL AGENDA STATEMENT

MEETING DATE: September 17, 2013

AGENDA ITEM NO. |

ITEM TITLE:

Warrant Register #8 for the period of 8/14/13 through 8/20/13 in the amount of \$1,826,586.12.
(Finance)

PREPARED BY: K. Apalategui

DEPARTMENT: Finance

PHONE: 619-336-4331

APPROVED BY: 

EXPLANATION:

Per Government Section Code 37208, attached are the warrants issued for the period of 8/14/13 through 8/20/13.

In accordance with Finance Department policy, below is an explanation of all warrants above \$50,000.00.

<u>Vendor</u>	<u>Check</u>	<u>Amount</u>	<u>Explanation</u>
Dell Marketing Corp	308707	234,869.27	Optiplex 3010 Minitowers
Public Emp Ret System	308741	328,546.24	Retirement Insurance Period 7/23/13 – 8/5/13

FINANCIAL STATEMENT:

APPROVED: 

Finance

ACCOUNT NO.

APPROVED: _____

MIS

N/A

ENVIRONMENTAL REVIEW:

This is not a project and, therefore, not subject to environmental review.

ORDINANCE: INTRODUCTION:

FINAL ADOPTION:

STAFF RECOMMENDATION:

Ratification of warrants in the amount of \$1,826,586.12

BOARD / COMMISSION RECOMMENDATION:

N/A

ATTACHMENTS:

Warrant Register #8



WARRANT REGISTER #8

8/20/2013

<u>PAYEE</u>	<u>DESCRIPTION</u>	<u>CHK NO</u>	<u>DATE</u>	<u>AMOUNT</u>
PROJECT PROFESSIONALS CORP.	8TH ST. SMART GROWTH	308690	8/15/13	42,212.50
SDG&E	GAS AND ELECTRIC UTILITIES / S A	308691	8/20/13	24.10
4 ALL PROMOS	MILANO KEYCHAIN, #199-A7212 GRAPHITE	308692	8/20/13	2,350.21
AETNA RESOURCES FOR LIVING	EMPLOYEE ASST PROGAM - AUG 2013	308693	8/20/13	733.90
AFFORDABLE SVC APPLIANCES	PARTS & LABOR REPAIRS ICE MACHINE	308694	8/20/13	365.00
ALDEMCO	FOOD CONSUMABLES	308695	8/20/13	4,055.98
ALL FRESH PRODUCTS	FOOD FOR NUTRITION CENTER	308696	8/20/13	851.75
ASSI SECURITY INC	CARD ACCESS READER	308697	8/20/13	3,655.00
BOUND TREE CORPORATION	KING VISION VIDEO LARYNGOSCOPE/PD	308698	8/20/13	5,315.99
BROADWAY AUTO GLASS	WINDSHIELD GREEN TINT/BLUE	308699	8/20/13	164.78
BUREAU VERITAS N AMERICA INC	SERVICES, APRIL TO JUNE, PD ELECTRICAL	308700	8/20/13	28,247.00
CAL EXPRESS	ATTORNEY SVCS FOR JULY 2013	308701	8/20/13	271.90
CALIFORNIA STATE LIBRARY	LITERACY SVCS GRANT	308702	8/20/13	3,100.72
COUNTY OF SAN DIEGO	RCS COMMUNICATIONS MAINTENANCE	308703	8/20/13	9,434.00
CPOA	TUITION: LEADERSHIP & ACCOUNTABILITY	308704	8/20/13	49.00
DALEY & HEFT LLP	LIABILITY CLAIM COSTS	308705	8/20/13	2,563.20
DECKSIDE POOL SERVICE	HYDROCHLORIC ACID, DRY CHLORINE	308706	8/20/13	780.00
DELL MARKETING CORP	DELL OPTIPLEX 3010 MINITOWERS	308707	8/20/13	234,869.27
DEPARTMENT OF JUSTICE	NEW EMPLOYEE FINGERPRINT TEST	308708	8/20/13	951.00
DISCOUNT SPECIALTY CHEMICALS	GOOP OFF GRAFFITI REMOVER (EXTRA STRONG)	308709	8/20/13	673.08
DIXIELINE BUILDERS	HOME PROGRAM REHAB - 138 NORTON AVE	308710	8/20/13	2,161.88
ECOLAB	DISHWASHER SUPPLIES / NUTRITION	308711	8/20/13	331.87
ESGIL CORPORATION	PLAN CHECKING SERVICES	308712	8/20/13	19,705.15
FBINAA CALIFORNIA CHAPTER	TUITION: 2013 ADVANCED TRAINER	308713	8/20/13	340.00
FEDEX	TECHNICAL PERSONNEL CHGS	308714	8/20/13	27.70
FERGUSON ENTERPRISES INC	MOP 45723 BUILDING/STRUCTURE	308715	8/20/13	126.69
GTC SYSTEMS INC	GTC SYSTEMS NETWORK	308716	8/20/13	1,657.50
HAMILTON MEATS & PROVISIONS	MEAT DELIVERY SERVICES	308717	8/20/13	422.38
KONE	ELEVATOR REPAIRS	308718	8/20/13	3,205.00
LEARNSOFT CONSULTING INC	LEARNSOFT TRAINING 7/18/13 MICROSOFT	308719	8/20/13	2,700.00
LOPEZ, T	TRANSLATION SERVICES FOR FY 2014	308720	8/20/13	210.00
MARCHANTE, A	REIMB - MILEAGE IN ANAHEIM, CA	308721	8/20/13	135.92
METRO AUTO PARTS DISTRIBUTOR	MOP 75943 AUTOMOTIVE PARTS	308722	8/20/13	415.54
METRO JPA-C/O PADRE DAM MWD	AGENCY SHARE OF MEMBERSHIP	308723	8/20/13	17,179.00
MEYERS/NAVE LAW CORP	BUSINESS AMORTIZATION HEARINGS	308724	8/20/13	1,742.50
MORENO, C	LIABILITY CLAIM COSTS	308725	8/20/13	350.00
NAPA AUTO PARTS	MOP 45735 AUTOMOTIVE PARTS	308726	8/20/13	49.59
NATIONAL CITY TROPHY	MOP 66556 CHERRY FINISH WRAP COVE-HOUSIN	308727	8/20/13	52.87
NATIONAL SCHOOL DISTRICT	REFUND/CLEANING & KEY DEPOSIT	308728	8/20/13	200.00
NEXUS INTEGRATED SOLUTIONS	INV SVC0064013 - PHONE MOVES AT CITY HAL	308729	8/20/13	1,020.00
OPPER & VARCO	LEGAL / TOD	308730	8/20/13	1,592.50
O'REILLY AUTO PARTS	MOP 758777 / AUTOMOTIVE SUPPLIES	308731	8/20/13	728.69
ORKIN PEST CONTROL	PEST MAINTENANCE	308732	8/20/13	375.73
PADRE JANITORIAL SUPPLIES	JANITORIAL SUPPLIES	308733	8/20/13	67.36
PARKHOUSE TIRE	HOL BUDD NEW STL 2HH	308734	8/20/13	1,201.73
PCS MOBILE	ITEM #FZ-G1AABACRM, PANASONIC / PD	308735	8/20/13	16,857.43
PENNY SAVER	STATE OF THE CITY 2013 ADVERTISING	308736	8/20/13	267.76
PRIDE FIRE SYSTEMS	REFUND - FIRE SUPPRESSION PERMIT	308737	8/20/13	703.00
PRO BUILD	MOP 45707 MISC SUPPLIES - NSD	308738	8/20/13	1,652.06



**WARRANT REGISTER #8
8/20/2013**

<u>PAYEE</u>	<u>DESCRIPTION</u>	<u>CHK NO</u>	<u>DATE</u>	<u>AMOUNT</u>
PRO-EDGE KNIFE	KNIFE SHARPENING SERVICES	308739	8/20/13	46.00
PRUDENTIAL OVERALL SUPPLY	MOP 45742 LAUNDRY SERVICES	308740	8/20/13	431.24
PUBLIC EMP RETIREMENT SYSTEM	SERVICE PERIOD 07/23/13-08/05/13	308741	8/20/13	328,546.24
PUN & MCGEADY	AUDIT SERVICES YR ENDING 6/30/13	308742	8/20/13	20,000.00
R J SAFETY SUPPLY	"ELITE" CLEAR AF LENS/BLACK	308743	8/20/13	169.39
RAUCH DETISCH & STEINKE	LEGAL / PLAZA BLVD / NAGRAJ	308744	8/20/13	3,710.94
SAN DIEGO & IMPERIAL COUNTIES	4TH ANNUAL LABOR DAY BREAKFAST	308745	8/20/13	70.00
SAN DIEGO HYDRAULICS	ALUMINUM BLOCK	308746	8/20/13	198.80
SAN DIEGO TROLLEY INC	MTS - TROLLEY FLAGGING SERVICES	308747	8/20/13	110.32
SAN DIEGO UNION TRIBUNE	ADVERTISEMENT - LEGAL NOTICES	308748	8/20/13	192.40
SDG&E	FACILITIES GAS & ELECTRIC	308749	8/20/13	34,053.68
SELTZER CAPLAN MCMAHON VITEK	PROFESSIONAL SVCS - JULY 31, 2013	308750	8/20/13	8,863.60
SKS INC.	BLUE DEF 2.5 GAL BOTTLE	308751	8/20/13	165.16
SMART & FINAL	MOP 45756 MISC SUPPLIES - COMM SVCS	308752	8/20/13	453.27
SOUTH COAST EMERGENCY	BRACKET, OPTION, MTG, TIP / FIRE	308753	8/20/13	76.58
SOUTH COASTAL	PLANNER REQUEST / WITOD	308754	8/20/13	150.00
SOUTHWEST SIGNAL SERVICE	TRAFFIC SIGNAL/STREET LIGHTING	308755	8/20/13	9,769.36
STAPLES ADVANTAGE	MOP 45704 OFFICE SUPPLIES - NSD	308756	8/20/13	81.19
SUPERIOR READY MIX	TACK OIL, 3/8 SHEET/COLDMIX	308757	8/20/13	309.31
SWRCB	PERMIT / D AVE ROUNDABOUT	308758	8/20/13	466.00
SYSCO SAN DIEGO	FOOD & CONSUMABLES	308759	8/20/13	4,129.91
T & T COMMUNITY PROPERTIES LLC	HOME PROGRAM ACQUISITION/REHAB	308760	8/20/13	13,419.00
THE LIGHTHOUSE INC	MOP 45726 AUTOMOTIVE PARTS	308761	8/20/13	236.73
TRAUMA INTERVENTION PROG	CDBG REIMBURSEMENT REQUEST	308762	8/20/13	8,000.00
U S BANK	CREDIT CARD EXP - PD	308763	8/20/13	667.60
U S HEALTHWORKS	MEDICAL SERVICES	308764	8/20/13	65.00
UNDERGROUND SERVICE ALERT	UNDERGROUND SERVICE ALERT	308765	8/20/13	145.50
VERIZON WIRELESS	VERIZON WIRELESS SVCS - SECTION 8	308766	8/20/13	506.08
VISTA PAINT	MOP 68834 PAINT - NSD	308767	8/20/13	807.06
WAXIE SANITARY SUPPLY	JANITORIAL SUPPLIES	308768	8/20/13	2,821.64
WILLY'S ELECTRONIC SUPPLY	MOP 45763 MISC SUPPLIES - MIS	308769	8/20/13	44.49
Z A P MANUFACTURING INC	REMOVE & REFACE STREET SIGNS	308770	8/20/13	4,643.79

A/P Total 859,498.51

	<u>Start Date</u>	<u>End Date</u>	
SECTION 8 HAPS PAYMENTS	8/14/2013	8/20/2013	11,563.61

PAYROLL

<u>Pay period</u>	<u>Start Date</u>	<u>End Date</u>	<u>Check Date</u>	
17	7/23/2013	8/5/2013	8/14/2013	955,524.00

GRAND TOTAL

\$ 1,826,586.12

Certification

IN ACCORDANCE WITH SECTION 37202, 37208, 372059 OF THE GOVERNMENT CODE, WE HEREBY CERTIFY TO THE ACCURACY OF THE DEMANDS LISTED ABOVE AND TO THE AVAILABILITY OF FUNDS FOR THE PAYMENT THEREOF AND FURTHER THAT THE ABOVE CLAIMS AND DEMANDS HAVE BEEN AUDITED AS REQUIRED BY LAW.



MARK ROBERTS, FINANCE

LESLIE DEESE, CITY MANAGER

FINANCE COMMITTEE

RONALD J. MORRISON, MAYOR-CHAIRMAN

LUIS NATIVIDAD, VICE-MAYOR

ALEJANDRA SOTELO-SOLIS, MEMBER

MONA RIOS, MEMBER

JERRY CANO, MEMBER

I HEREBY CERTIFY THAT THE FOREGOING CLAIMS AND DEMANDS WERE APPROVED AND THE CITY TREASURER IS AUTHORIZED TO ISSUE SAID WARRANTS IN PAYMENT THEREOF BY THE CITY COUNCIL ON THE 17th OF SEPTEMBER, 2013.

AYES _____

NAYS _____

ABSENT _____

**CITY OF NATIONAL CITY, CALIFORNIA
COUNCIL AGENDA STATEMENT**

MEETING DATE: September 17, 2013

AGENDA ITEM NO. |

ITEM TITLE:

Warrant Register #9 for the period of 8/21/13 through 8/27/13 in the amount of \$1,358,498.86.
(Finance)

PREPARED BY: K. Apalategui

DEPARTMENT: Finance

PHONE: 619-336-4331

APPROVED BY: 

EXPLANATION:

Per Government Section Code 37208, attached are the warrants issued for the period of 8/21/13 through 8/27/13.

In accordance with Finance Department policy, below is an explanation of all warrants above \$50,000.00.

<u>Vendor</u>	<u>Check</u>	<u>Amount</u>	<u>Explanation</u>
City of San Diego	308790	1,250,073.00	Transportation & treatment Of Wastewater

FINANCIAL STATEMENT:

APPROVED:  Finance

ACCOUNT NO. |

APPROVED: _____ MIS

N/A

ENVIRONMENTAL REVIEW:

This is not a project and, therefore, not subject to environmental review.

ORDINANCE: INTRODUCTION:

FINAL ADOPTION:

STAFF RECOMMENDATION:

Ratification of warrants in the amount of \$1,358,498.86

BOARD / COMMISSION RECOMMENDATION:

N/A

ATTACHMENTS:

Warrant Register #9



**WARRANT REGISTER # 9
8/27/2013**

<u>PAYEE</u>	<u>DESCRIPTION</u>	<u>CHK NO</u>	<u>DATE</u>	<u>AMOUNT</u>
ADAMSON POLICE PRODUCTS	VESTS / POLICE	308772	8/27/13	3,043.28
AIRGAS WEST	MOP 45714 AUTOMOTIVE PARTS	308773	8/27/13	58.64
ALL FRESH PRODUCTS	FOOD / NUTRITION CENTER	308774	8/27/13	256.46
ATKINS NORTH AMERICA INC	NC TAX ROLL PREPARATION 2014	308775	8/27/13	465.00
AYLES, T	WC CLAIM COSTS	308776	8/27/13	3,512.40
BEST BEST & KRIEGER LLP	REGISTRATION - TRAINING FOR J. IBARRA	308777	8/27/13	75.00
BEST BUY	1- SONIC FREE RIDERS	308778	8/27/13	139.13
BEVERIDGE, M	EDUCATIONAL REIMBURSEMENT / FIRE	308779	8/27/13	100.00
BLACKIE'S TROPHIES AND AWARDS	MOP 67727 METAL NAME TAG - PD	308780	8/27/13	64.80
BROADWAY AUTO ELECTRIC	MOP 72447 AUTOMOTIVE PARTS	308781	8/27/13	174.00
CALIFORNIA ASSOCIATION OF	ANNUAL SEMINAR - J OLSON	308782	8/27/13	349.00
CALIFORNIA ASSOCIATION OF	ANNUAL SEMINAR - R SORIANO	308783	8/27/13	349.00
CALIFORNIA ASSOCIATION OF	CERTIFICATION EXAM - R SORIANO	308784	8/27/13	150.00
CALIFORNIA ASSOCIATION OF	CERTIFICATION EXAM - J OLSON	308785	8/27/13	150.00
CAMPOS ROOFING	REFUND - OVERPAYMENT	308786	8/27/13	10.00
CASTILLO, C	REFUND - POOL PUNCH PASS	308787	8/27/13	26.00
CHILDREN'S HOSPITAL	CHILD ABUSE EXAMS	308788	8/27/13	441.00
CHRISTENSEN & SPATH LLP	LEGAL SERVICES	308789	8/27/13	8,550.00
CITY OF SAN DIEGO	TRANSPORTATION/TREATMENT WASTEWATER	308790	8/27/13	1,250,073.00
CORDERO, E	SUBSISTENCE - SHERMAN BLOCK LEADERSHIP	308791	8/27/13	468.00
CORDERO, E	SUBSISTENCE - SHERMAN BLOCK LEADERSHIP	308792	8/27/13	468.00
COUNTY OF SAN DIEGO	RCS SYSTEM MAINTENANCE / JUL 2013	308793	8/27/13	9,434.00
COUNTY OF SAN DIEGO	MAIL PROCESSING SERVICES / JUN 2013	308794	8/27/13	3,969.78
COX COMMUNICATIONS	COX COMMUNICATIONS DATA FY14	308795	8/27/13	3,129.40
DANIELS TIRE SERVICE	TIRES FOR CITY FLEET AS NEEDED FY 2014	308796	8/27/13	1,581.67
DATA TICKET INC	CITATION PROCESSING / JUL 2013	308797	8/27/13	4,576.35
DUNBAR ARMORED INC	ARMORED SVCS - FINANCE	308798	8/27/13	164.39
BRAINARD, E	SEMINAR REGISTRATION FEE	308799	8/27/13	475.00
BENEDEK, E	EDUCATIONAL REIMBURSEMENT / FIRE	308800	8/27/13	100.00
ESGIL CORPORATION	PLAN CHECK SERVICES / FIRE	308801	8/27/13	2,368.55
EXPERIAN	POLICE CREDIT CHECKS	308802	8/27/13	27.72
FEDEX	DEPT OF TRANSP - ENG	308803	8/27/13	304.25
FERGUSON ENTERPRISES INC	MOP 45723 PLUMBING MATERIAL	308804	8/27/13	19.41
GARCIA, L	REFUND - POOL PUNCH PASS	308805	8/27/13	12.00
GARCIA, R	REFUND - POOL PUNCH PASS	308806	8/27/13	12.00
GRANICUS INC	GRANICUS WEBCASTING FOR FY14	308807	8/27/13	1,477.35
GUTLAY, R	REIMB / GFOA TRAINING / FINANCE	308808	8/27/13	164.22
HAMILTON MEATS & PROVISIONS	MEAT DELIVERY SERVICES / NUTRITION	308809	8/27/13	639.98
HDL COREN & CONE	PROPERTY TAX JUL-SEPT 2013	308810	8/27/13	2,400.00
HINDERLITER DE LLAMAS & ASSOC	SALES TAX 3RD QTR - AUDIT SVCS	308811	8/27/13	2,778.65
HYDRO SCAPE PRODUCTS INC	MOP 45720 VALVES & FITTINGS	308812	8/27/13	291.14
JERAULDS CAR CARE CENTER	R&M CITY VEHICLES AS NEEDED FY 2014	308813	8/27/13	562.80
JOHN DEERE LANDSCAPES	MOP 69277 HORTICULTURAL ITEMS	308814	8/27/13	42.12
KELLY PAPER CO	CARDSTOCK PAPER	308815	8/27/13	452.48
KIMLEY HORN AND ASSOC INC	DEP #1808 - PLAZA BONITA BIKE PATH	308816	8/27/13	3,905.75
LANGUAGE LINE SERVICES	LANGUAGE LINE INTERPRETATION / PD	308817	8/27/13	13.29
LEDEZMA, M	REFUND OF BLDG PLAN CHECK FEES	308818	8/27/13	139.02
LOPEZ, T	TRANSLATION SERVICES FOR FY 2014	308819	8/27/13	140.00
LUCAS, M	EDUCATIONAL REIMBURSEMENT / FIRE	308820	8/27/13	100.00



**WARRANT REGISTER # 9
8/27/2013**

<u>PAYEE</u>	<u>DESCRIPTION</u>	<u>CHK NO</u>	<u>DATE</u>	<u>AMOUNT</u>
MAN K-9 INC.	MAINT TRAINING / POLICE K-9 / JUL 2013	308821	8/27/13	800.00
METRO AUTO PARTS DISTRIBUTOR	MOP 75943 AUTOMOTIVE PARTS	308822	8/27/13	526.46
NAPA AUTO PARTS	MOP 45735 AUTOMOTIVE PARTS	308823	8/27/13	124.46
PERRY FORD	MOP 45703 AUTOMOTIVE PARTS	308824	8/27/13	469.33
PERRY MOTORS OF NAT CITY LLC	INV 5019791 - DEADENDER BODY PANEL	308825	8/27/13	364.72
POWERSTRIDE BATTERY CO INC	MOP 67839 AUTOMOTIVE PARTS	308826	8/27/13	376.41
PRUDENTIAL OVERALL SUPPLY	MOP 45742 LAUNDRY SERVICES	308827	8/27/13	378.96
PURPOSE CONSULTING & ROGERS, I	REFUND OF C&D FEES	308828	8/27/13	230.02
RON BAKER CHEVROLET	REFUND - POOL PUNCH PASS	308829	8/27/13	40.00
RUSS' BEE REMOVAL	MOP 45751 AUTOMOTIVE PARTS	308830	8/27/13	210.80
S D COUNTY SHERIFF'S DEPT	BEE REMOVAL SERVICES	308831	8/27/13	400.00
SAFRAN MORPHOTRUST	SHERIFF'S RANGE USE / POLICE	308832	8/27/13	900.00
SAN DIEGO & IMPERIAL COUNTIES	INVESTIGATIVE SVCS - JUNE 2013	308833	8/27/13	52.00
SAN DIEGO & IMPERIAL COUNTIES	4TH ANNUAL LABOR DAY BREAKFAST	308834	8/27/13	35.00
SAN DIEGO & IMPERIAL COUNTIES	4TH ANNUAL LABOR DAY BREAKFAST	308835	8/27/13	35.00
SAN DIEGO & IMPERIAL COUNTIES	4TH ANNUAL LABOR DAY BREAKFAST	308836	8/27/13	35.00
SAN DIEGO PET & LAB SUPPLY	MOP 45753 K-9 FOOD - PD	308837	8/27/13	313.35
SDG&E	STREET DIVISION GAS & ELECTRIC CHARGES	308838	8/27/13	29,887.81
SEAPORT MEAT COMPANY	FOOD / NUTRITION CENTER	308839	8/27/13	450.07
SMART & FINAL	MOP 45756 MISC SUPPLIES - PD	308840	8/27/13	250.53
SMART SOURCE OF CA LLC	MOP 63845 FALSE ALARM NOTICE - PD	308841	8/27/13	389.14
STAPLES ADVANTAGE	MOP 45704 OFFICE SUPPLIES - FINANCE	308842	8/27/13	517.82
STILES, J	REIMBURSEMENT - RECERTIFICATION	308843	8/27/13	200.00
STILES, J	REIMB - ETHICAL LEADERSHIP	308844	8/27/13	142.40
STILES, J	EDUCATIONAL REIMBURSEMENT / FIRE	308845	8/27/13	100.00
SWEETWATER AUTHORITY	WATER UTILITIES / S A	308846	8/27/13	42.00
SYSCO SAN DIEGO	FOOD & CONSUMABLES / NUTRITION	308847	8/27/13	2,100.46
U S BANK	CREDIT CARD EXP - COMM SVCS	308848	8/27/13	395.00
UNION TRIBUNE PUB CO	PUBLIC NOTICING/PLANNING COMMISSION	308849	8/27/13	1,496.00
UNITED ROTARY BRUSH	STREET SWEEPER REPAIRS	308850	8/27/13	265.78
VALLEY INDUSTRIAL SPECIALTIES	MOP 46453 PLUMBING MATERIAL	308851	8/27/13	175.07
VCA EMERGENCY ANIMAL HOSPITAL	STRAY ANIMAL VET / POLICE	308852	8/27/13	524.52
VCA MAIN ST ANIMAL HOSPITAL	K9 VET CARE / POLICE	308853	8/27/13	283.78
VERIZON WIRELESS	VERIZON CELL SERVICE FY14	308854	8/27/13	6,490.53
VERIZON WIRELESS	CELL PHONE CHGS 6/22/13 - 7/21/13	308855	8/27/13	60.19
WESTFLEX INDUSTRIAL	MOP 63850 AUTOMOTIVE PARTS	308856	8/27/13	476.21
ZEFERINO, L	EDUCATIONAL REIMBURSEMENT / PD	308857	8/27/13	756.01

A/P Total 1,358,498.86

GRAND TOTAL

\$ 1,358,498.86

Certification

IN ACCORDANCE WITH SECTION 37202, 37208, 372059 OF THE GOVERNMENT CODE, WE HEREBY CERTIFY TO THE ACCURACY OF THE DEMANDS LISTED ABOVE AND TO THE AVAILABILITY OF FUNDS FOR THE PAYMENT THEREOF AND FURTHER THAT THE ABOVE CLAIMS AND DEMANDS HAVE BEEN AUDITED AS REQUIRED BY LAW.



MARK ROBERTS, FINANCE

LESLIE DEESE, CITY MANAGER

FINANCE COMMITTEE

RONALD J. MORRISON, MAYOR-CHAIRMAN

LUIS NATIVIDAD, VICE-MAYOR

ALEJANDRA SOTELO-SOLIS, MEMBER

MONA RIOS, MEMBER

JERRY CANO, MEMBER

I HEREBY CERTIFY THAT THE FOREGOING CLAIMS AND DEMANDS WERE APPROVED AND THE CITY TREASURER IS AUTHORIZED TO ISSUE SAID WARRANTS IN PAYMENT THEREOF BY THE CITY COUNCIL ON THE 17th OF SEPTEMBER, 2013.

AYES _____

NAYS _____

ABSENT _____

**CITY OF NATIONAL CITY, CALIFORNIA
COUNCIL AGENDA STATEMENT**

MEETING DATE: September 17, 2013

AGENDA ITEM NO. |

ITEM TITLE:

TEMPORARY USE PERMIT – 2013 State of the City Address sponsored by the City of National City on October 17, 2013 from 5pm to 8pm at Cornerstone Church located at 1914 Sweetwater Road. This is a city-sponsored event per Council Policy No. 804.

PREPARED BY: Vianey Rivera

DEPARTMENT: Neighborhood Services Division

PHONE: (619) 336-4364

APPROVED BY: 

EXPLANATION:

This is a request from the City of National City to conduct the 2013 State of the City Address event on October 17, 2013 from 5pm to 8pm at 1914 Sweetwater Road.

This is an annual event where the Mayor addresses National City residents regarding city accomplishments to date. Various vendors will provide food samples.

No city street closures required for this event.

FINANCIAL STATEMENT:

APPROVED: _____ Finance

ACCOUNT NO.

APPROVED: _____ MIS

The City has incurred \$237.00 for processing the TUP through various City departments, and \$864.90 for Public Works.

Total fees are \$1,101.00.

ENVIRONMENTAL REVIEW:

ORDINANCE: INTRODUCTION:

FINAL ADOPTION:

STAFF RECOMMENDATION:

Approve the Application for a Temporary Use Permit subject to compliance with all conditions of approval and waiver of fees according to Council Policy No. 804.

BOARD / COMMISSION RECOMMENDATION:

ATTACHMENTS:

Application for a Temporary Use Permit with recommended approvals and conditions of approval.

Type of Event:

Public Concert Fair Festival
 Parade Demonstration Circus
 Motion Picture Grand Opening Other _____ x _____

Community event
 Block Party

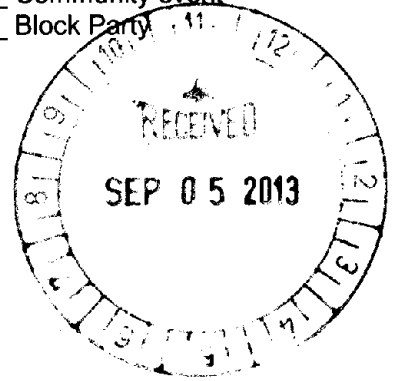

Event Title: 2013 State of the City Address

Event Location: Cornerstone Church, 1914 Sweetwater Road

Event Date(s): From 10/17 to 10/17

Actual Event Hours: 5:00/pm to 8:00/pm

Total Anticipated Attendance: 500 Participants _____ Spectators)

Setup/assembly/construction Date: 10/17 Start time: 10:00 am

Please describe the scope of your setup/assembly work (specific details): Setting up tables, chairs, canopies in case of rain

Dismantle Date: 10/17 Completion Time: 10:00 /pm

List any street(s) requiring closure as a result of this event. Include street name(s), day and time of closing and day and time of reopening.

N/A

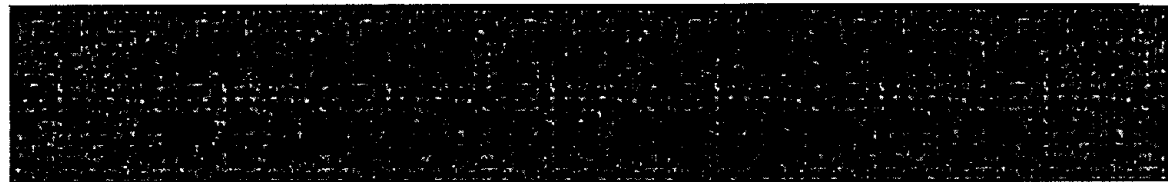

Sponsoring Organization: City of National City

Chief Officer of Organization (Name) Mayor Ron Morrison

Applicant (Name): Office of Mayor Ron Morrison

Address: 1243 National City Blvd., National City Daytime

Phone: (619) 336-4236 Evening Phone: () _____

Fax: () _____ E-Mail: rmorrison@nationalcityca.gov

Contact Person "on site" day of the event: Josie Flores- Clark Cellular: 619-787-3687

NOTE: THIS PERSON MUST BE IN ATTENDANCE FOR THE DURATION OF THE EVENT AND IMMEDIATELY AVAILABLE TO CITY OFFICIALS



Is your organization a "Tax Exempt, nonprofit" organization? YES NO N/A

Are admission, entry, vendor or participant fees required? __ YES _X_ NO

If YES, please explain the purpose and provide amount(s):

\$ N/A ___ Estimated Gross Receipts including ticket, product and sponsorship sales from this event.

\$ ___ N/A _____ Estimated Expenses for this event.

\$ ___ N/A _____ What is the projected amount of revenue that the Nonprofit Organization will receive as a result of this event?



Please provide a **DETAILED DESCRIPTION** of your event. Include details regarding any components of your event such as the use of vehicles, animals, rides or any other pertinent information about the event.

Mayor Ron Morrison will address City residents regarding City accomplishments to date. Various restaurants will provide food samples to the guests after the program. The Color Guard will be present at the event.

__ YES __ NO If the event involves the sale of cars, will the cars come exclusively from National City car dealers?
If NO, list any additional dealers involved in the sale:



__ YES _X_ NO Does the event involve the sale or use of alcoholic beverages?

__ YES _X_ NO Will items or services be sold at the event? If yes, please describe:

__ YES _X_ NO Does the event involve a moving route of any kind along streets, sidewalks or highways? If YES, attach a detailed map of your proposed route indicate the direction of travel, and provide a written narrative to explain your route.

__ YES _X_ NO Does the event involve a fixed venue site? If YES, attach a detailed site map showing all streets impacted by the event.

__X YES __ NO Does the event involve the use of tents or canopies? If YES: Number of

tent/canopies 25 Sizes 10 X 10 if needed NOTE: A separate Fire Department permit is required for tents or canopies.

 YES X NO Will the event involve the use of the **City** or **your** stage or PA system?
SPECIFY: _____

In addition to the route map required above, please attach a **diagram** showing the overall layout and set-up locations for the following items:

Alcoholic and Nonalcoholic Concession and/or Beer Garden areas.
 Food Concession and/or Food Preparation areas Please describe how food will be served at the event: _____
If you intend to cook food in the event area please specify the method:
 X GAS X ELECTRIC CHARCOAL OTHER (Specify): _____

Portable and/or Permanent Toilet Facilities
Number of portable toilets: (1 for every 250 people is required, unless the applicant can show that there are facilities in the immediate area available to the public during the event)

- Tables # 45 and Chairs # 100
- Fencing, barriers and/or barricades
- Generator locations and/or source of electricity
- Canopies or tent locations (include tent/canopy dimensions)
- Booths, exhibits, displays or enclosures
- Scaffolding, bleachers, platforms, stages, grandstands or related structures
- Vehicles and/or trailers
- Other related event components not covered above
- Trash containers and dumpsters

(Note: You must properly dispose of waste and garbage throughout the term of your event and immediately upon conclusion of the event the area must be returned to a clean condition.) Number of trash cans: _____ Trash containers with lids: _____

Describe your plan for clean-up and removal of waste and garbage during and after the event:



Please describe your procedures for both Crowd Control and Internal Security: Extra patrol NCPD and church staff

 YES X NO Have you hired any Professional Security organization to handle security arrangements for this event? If YES, please list:

Security Organization: _____

Security Organization Address: _____

Security Director (Name): _____ Phone: _____

X_ YES ___ NO Is this a night event? If YES, please state how the event and surrounding area will be illuminated to ensure safety of the participants and spectators: Indoor event and parking lot area is lighted.

Please indicate what arrangement you have made for providing First Aid Staffing and Equipment.
First Aid station with the church

Please describe your Accessibility Plan for access at your event by individuals with disabilities:
Church and facility is ADA compliant



Please provide a detailed description of your PARKING plan:
Church property parking and shuttle provided for transport

Please describe your plan for DISABLED PARKING:
Posted parking areas

Please describe your plans to notify all residents, businesses and churches impacted by the event: _____ N/A _____

NOTE: Neighborhood residents must be notified 72 hours in advance when events are scheduled in the City parks.

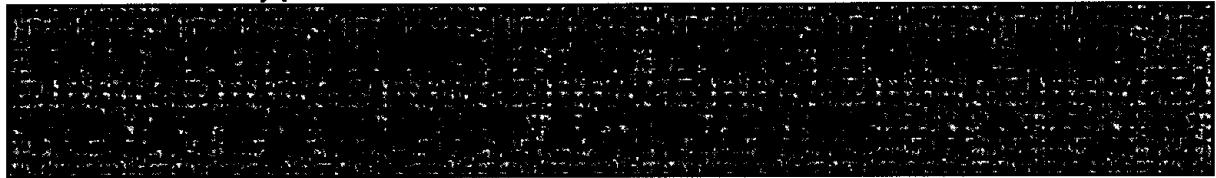

___ YES ___X___ NO Are there any musical entertainment features related to your event? If YES, please state the number of stages, number of bands and type of music. Number of Stages: _____ Number of Bands: _____

Type of Music: _____

___ YES ___X___ NO Will sound amplification be used? If YES, please indicate: Start time: _____ am/pm Finish Time _____ am/pm

___ YES ___X___ NO Will sound checks be conducted prior to the event? If YES, please indicate: Start time: _____ am/pm Finish Time _____ am/pm

Please describe the sound equipment that will be used for your event:

YES NO Fireworks, rockets, or other pyrotechnics? If YES, please describe:

YES NO Any signs, banners, decorations, special lighting? If YES, please describe:

_____ Sponsor banners, generator lighting

Revised 02/29/12

City of National City

PUBLIC PROPERTY USE HOLD HARMLESS AND INDEMNIFICATION AGREEMENT

Persons requesting use of City property, facilities or personnel are required to provide a minimum of \$1,000,000 combined single limit insurance for bodily injury and property damage which includes the City, its officials, agents and employees named as additional insured and to sign the Hold Harmless Agreement. Certificate of insurance must be attached to this permit.

Organization _____

Person in Charge of Activity _____

Address _____

Telephone _____ **Date(s) of Use** _____

HOLD HARMLESS AGREEMENT

As a condition of the issuance of a temporary use permit to conduct its activities on public or private property, the undersigned hereby agree(s) to defend, indemnify and hold harmless the City of National City and the Parking Authority and its officers, employees and agents from and against any and all claims, demands, costs, losses, liability or, for any personal injury, death or property damage, or both, or any litigation and other liability, including attorneys fees and the costs of litigation, arising out of or related to the use of public property or the activity taken under the permit by the permittee or its agents, employees or contractors.

Signature of Applicant Official Title Date

 (Mayor) 9-9-13

For Office Use Only

Certificate of Insurance Approved _____ Date _____

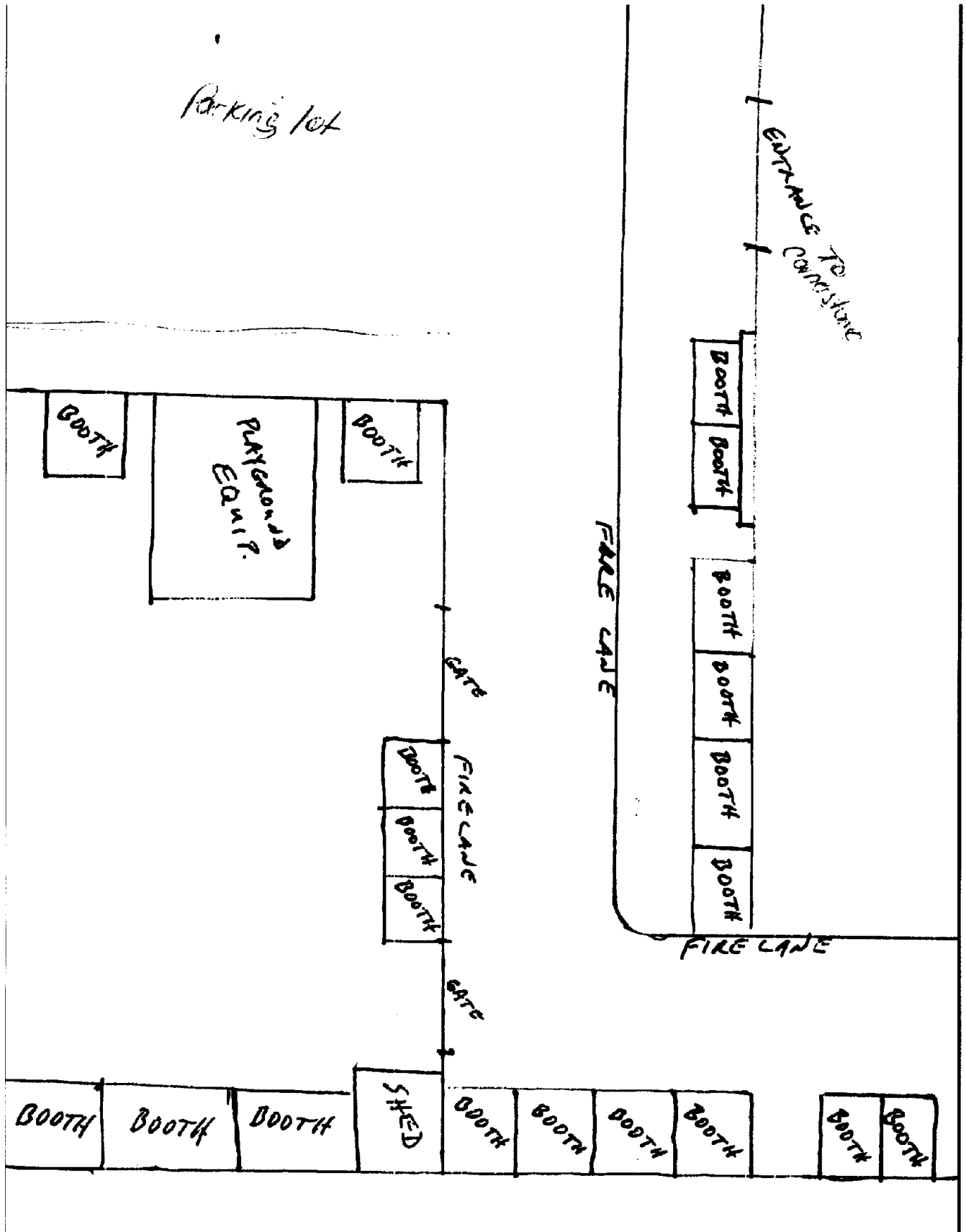

**CITY OF NATIONAL CITY
NEIGHBORHOOD SERVICES DIVISION
APPLICATION FOR A TEMPORARY USE PERMIT
RECOMMENDATIONS AND CONDITIONS**

SPONSORING ORGANIZATION: City of National City
EVENT: 2013 State of the City Address
DATE OF EVENT: **October 17, 2013**
TIME OF EVENT: 5 p.m. to 8 p.m.

APPROVALS:

DEVELOPMENT SERVICES	YES [x]	NO []	SEE CONDITIONS [x]
RISK MANAGER	YES [x]	NO []	SEE CONDITIONS [x]
PUBLIC WORKS	YES [x]	NO []	SEE CONDITIONS [x]
FINANCE	YES [x]	NO []	SEE CONDITIONS [x]
FIRE	YES [x]	NO []	SEE CONDITIONS [x]
COMMUNITY SERVICES	YES [x]	NO []	SEE CONDITIONS [x]
POLICE	YES [x]	NO []	SEE CONDITIONS [x]
CITY ATTORNEY	YES [x]	NO []	SEE CONDITIONS [x]

CONDITIONS OF APPROVAL:

DEVELOPMENT SERVICES (619) 336-4318

Development Services has no involvement in this event.

RISK MANAGER (619) 336-4370

Provide valid copy of insurance certificate naming the City of National City.

Provide Additional insured endorsement naming the City of National City as an additional named insured

PUBLIC WORKS (619)336-4580

Facilities Division

Estimated costs to provide facilities personnel are as follows:

• 2 Custodians 6 hrs ea Regular Time x \$14.84/hr	=	\$ 178.08
• 2 Tradesmen 6 hrs ea Regular Time x \$22.21/hr	=	266.52
• 3 Custodians 3 hrs ea Overtime x \$22.26/hr	=	200.34
• 1 Tradesman 3 hrs Overtime x \$33.32/hr	=	99.96
• 45 tables @ \$1 ea	=	45.00
• 100 chairs @ \$.75 ea	=	<u>75.00</u>
• TOTAL	=	<u>\$ 864.90</u>

Stipulations required by the Fire Department for this event are as follows:

- 1) Maintain Fire Department access at all times.
- 2) Means of egress shall not be obstructed in any manner and shall remain free of any material or matter where its presence would obstruct or render the means of egress hazardous.
- 3) Access for Fire Department shall be maintained at all times. At no time shall fire lanes, fire hydrants, fire protection systems of all types etc. be obstructed at any time. A minimum of 20 feet wide shall be maintained for the use of fire lanes. **A 28 foot turning radius shall be required at all turn lanes surrounding structure**
- 4) Provide 2A:10BC fire extinguishers in the food areas. Extinguisher to be **mounted in a visible location** between 3½' to 5' from the floor to the top of the extinguisher. Maximum travel distance from one extinguisher to another shall not be more than 75 feet travel distance. **All fire extinguishers to have a current "State Fire Marshal Tag" attached.** *Please see attached example*
- 6) If tents or canopies are used, tents having an area in excess of 200 square feet and or canopies in excess of 400 square feet or multiple tents and or canopies placed together equaling or greater than the above stated areas, are to be used, they shall be flame-retardant treated with an approved State Fire Marshal seal attached. A ten feet separation distance must be maintained between tents and canopies. A permit from the Fire Department must be obtained. ***Cooking shall not be permitted under tents or canopies unless the tents or canopies meet "State Fire Marshal approval for cooking.*** Certificate of State Fire Marshal flame resistance shall be provided to the National City Fire Department if applicable.

Canopies:

0 – 400 sf -	\$0
401 – 500 sf -	\$250.00
501 – 600 sf -	\$300.00
601 – 700 sf -	\$400.00

Tents:

0 –200 sf -	\$200.00
201 – (+) sf -	\$400.00

- 7) **Canopies (10x10's) can be grouped together and are not to exceed four in a group (400 square feet). A separation of 10 feet shall be required between groups of four (400 Square feet). If canopies grouped together exceed 400 square feet, a charge and permit will be required by the National City Fire Department prior to the event. Please contact the National City Fire Department for requirements.**
- 8) Internal combustion power sources (Generator) that may be used for the event shall be of adequate capacity to permit uninterrupted operation during normal operating hours. Fueling shall be performed prior to beginning of event.
- 9) Internal combustion power sources shall be isolated from contact with the public by either physical guards, fencing or an enclosure. Internal combustion power shall be at least **20 feet away from tents and people.**
- 10) Any electrical power used is to be properly grounded and approved. Extension cords shall be used as "Temporary Wiring" Only.
- 11) A fire safety inspection is to be conducted by the Fire Department prior to operations of the event to include all cooking areas and grounds surrounding the event.
- 12) First Aid will be provided by organization
- 13) Fees can only be waived by City Council.

13) Fire Department if applicable. *If canopies maintain a ten feet separation distance from one another, no charge will be assessed*

Canopies:

0 – 400 sf -	\$0
401 – 500 sf -	\$250.00
501 – 600 sf -	\$300.00
601 – 700 sf -	\$400.00

Tents:

0 –200 sf -	\$200.00
-------------	----------

201 – (+) sf - \$400.00

NOTE: Booths can be grouped in multiples of 4 not to exceed 400 square feet. A separation of ten feet between multiples of 4 booths shall be required

14) First Aid will be provided by organization

Note: Fees can only be waived by City Council.

COMMUNITY SERVICES

No comments.

POLICE

Extra Patrol will be provided for this event.

CITY ATTORNEY

Requires an indemnification and hold harmless agreement, and a policy of general liability insurance, with the City and its officials, employees, agents and volunteers as additional insureds, with amounts of coverage to be determined by the Risk Manager.

**CITY OF NATIONAL CITY, CALIFORNIA
COUNCIL AGENDA STATEMENT**

MEETING DATE: September 17, 2013

AGENDA ITEM NO. _____

ITEM TITLE:

An Ordinance of the City Council of the City of National City Amending Sections 18.30.360 and 18.41.020 (C) of Title 18 (Land Use Code) of the National City Municipal Code related to fast food restaurant locational requirements and drive-through business design guidelines. (Applicant The Focus Group) (Case File 2013-12 A)

PREPARED BY:  Martin Reeder, AICP

DEPARTMENT: Planning

PHONE: 619-336-4313

APPROVED BY: 

EXPLANATION:

The City Council held a public hearing on proposed changes to amend Title 18 of the National City Municipal Code pertaining to fast food restaurant locational requirements and drive-through business design guidelines, at a Public Hearing on September 3, 2013. The Ordinance was introduced at the same meeting. However, there were questions regarding allowable uses in the MXC-2 and MXD-2 zones and also regarding General Plan language related to fast food restaurants.

The Land Use Matrix for the Mixed-Use zones is attached for your review, as is the Health & Environmental Justice Element of the General Plan. This element has two General Plan Policies related to fast food uses (HEJ-4.2 and HEJ-5.4). The rationale for the policies was to encourage healthy food options whenever possible in order to alleviate the prevalence of excess weight and obesity.

Final adoption of the attached ordinance is needed to complete the Code Amendment process.

FINANCIAL STATEMENT:

APPROVED: _____ Finance

ACCOUNT NO. _____

APPROVED: _____ MIS

ENVIRONMENTAL REVIEW:

Negative Declaration

ORDINANCE: INTRODUCTION: FINAL ADOPTION:

STAFF RECOMMENDATION:

Approve the Ordinance

BOARD / COMMISSION RECOMMENDATION:

N/A

ATTACHMENTS:

1. Land Use Matrix for Mixed Use Zones (NCCM 18.24.050)
2. General Plan - Health & Environmental Justice Element
3. Ordinance

18.24.050 Allowed land uses and permit requirements.

A. Purpose. This section identifies permitted uses within the mixed-use zones.

B. Permitted Land Uses. Land uses permitted in the mixed-use zones shall be as specified in Table 18.24.050 (Allowed Land Uses - Mixed-Use Zones).

**TABLE 18.24.050
Allowed Land Uses
Mixed-Use Zones**

Land Use	Permit Required by Zone				Specific Use Regulations
	MXC-1 (a)	MXC-2	MXD-1	MXD-2	
Alcohol, sales for off-site consumption (accessory to retail sales)	C	C	C	C	Section 18.30.050
Alcohol, sales for on-site consumption (accessory to eating places)	C	C	C	C	Section 18.30.050
Animal boarding/kennel, small (setback 150 feet from single-family residential zones)	C	C	C	C	
Bar/nightclub	C	C	C	C	Section 18.30.050
Bed and breakfast inn (B&B)	C	C	C	C	
Car wash, automatic and full service	P	P	P	P	
Car wash, manual	C	C	C	C	
Civic, fraternal, community, and cultural facilities	P	P	P	P	
Commercial recreation, indoor	P	P	P	P	
Commercial recreation, outdoor	M	M	M	M	
Convalescent / nursing home / hospice	P	P	P	P	
Child day care center	M	M	M	M	Section 18.30.070
Family day care home, small (accessory)	P	P	P	P	Section 18.30.080
Family day care home, large (accessory)	M	M	M	M	Section 18.30.080
Convenience store (accessory to gas service station)	P	P	P	P	Section 18.30.190
Dormitory (accessory to school)	C	C	C	C	

Land Use	Permit Required by Zone				Specific Use Regulations
	MXC-1 (a)	MXC-2	MXD-1	MXD-2	
Dwelling unit, single detached (b)	P	P	P	P	
Dwelling unit, single attached (b)	P	P	P	P	
Dwelling unit, multiple (b)	P	P	P	P	
Eating places, dine in	P	P	P	P	
Eating places, drive-through/ take-out	C	C	C	C	
Farmer's market	C	C	C	C	
Gasoline service station	C	C	C	C	Section 18.30.190
Goods and services, retail	P	P	P	P	
Guidance/social assistance services	C	C	C	C	
Heliport/helistop (accessory)	—	—	C	C	
Home occupation (accessory)	P	P	P	P	
Hospital	—	—	C	C	
Hotel, motel, and related services	P	P	P	P	Section 18.30.270
Maintenance yards	C	C	C	C	
Medical offices/clinics and laboratories	P	P	P	P	
Offices	P	P	P	P	
Open space reserves	P	P	P	P	
Parking garage	P	P	P	P	
Parks (passive and active recreation)	P	P	P	P	
Pawn shops	C	C	C	C	Section 18.30.330
Payday lenders	C	C	C	C	Section 18.30.320
Private/public educational institutions, schools	C	C	C	C	
Public assembly	C	C	C	C	
Public safety facilities	P	P	P	P	
Rectory (accessory to religious facility)	P	P	P	P	
Recycling facility, small (accessory)	P	P	P	P	Section 18.30.170

Land Use	Permit Required by Zone				Specific Use Regulations
	MXC-1 (a)	MXC-2	MXD-1	MXD-2	
Recycling facility, mobile	C	C	C	C	Section 18.30.170
Renewable energy infrastructure (accessory)	P	P	P	P	Section 18.30.210/ 18.30.300; California Building Code
Sidewalk café (accessory)	P	P	P	P	Section 18.30.200
Storage building (accessory)	P	P	P	P	
Tattoo parlors and body piercing establishments	C	C	C	C	Section 18.30.310
Telecommunication facilities, commercial	C	C	C	C	Section 18.30.220
Tobacco specialty shops	—	—	C	C	Section 18.30.230
Transitional/supportive housing (b)	P	P	P	P	
Urban agriculture	P	P	P	P	Section 18.30.240
Utility facilities, minor	P	P	P	P	
Utility facilities, major	C	C	C	C	
Vending machines (accessory)	P	P	P	P	Section 18.30.150(E)
Veterinary clinics/hospitals	C	C	C	C	Section 18.30.250
P Permitted C Conditional use permit M Minor use permit (ministerial) — Not permitted					

Notes:

(a) Visitor serving, tourist commercial, and recreational uses are prioritized in the coastal zone.

(b) Residential uses are not permitted in the coastal zone west of I-5.

(Ord. No. 2012-2372; Exh. B-1, 2-7-2012)



Health and Environmental Justice (HEJ)



Public Health - A state of complete physical, mental, and social wellbeing, not just the absence of disease or infirmity. (World Health Organization)

Environmental Justice - The fair treatment and meaningful participation of people of all races, cultures, and incomes with respect to the development, adoption, implementation, and enforcement of environmental laws, regulations, and policies. (Government Code §65040.12).

A. Introduction

The way we design and build the human environment has a profound impact on both public health and environmental justice. Planning decisions related to transportation systems, density and intensity of uses, land use practices, and street design influence: how much we walk, ride a bicycle, drive a car, or take public transportation; the level of our stress; the types of food we eat; and the quality of our air and water – all factors which affect our health. For example, the more we drive, the more our vehicles emit harmful gases and particles into the air, which can lead to respiratory problems such as asthma. A compact, mixed-use development pattern that reduces reliance on automobiles and increases public transit opportunities can improve air quality and respiratory health¹.

In addition, the presence or absence of sidewalks and bike routes, heavy traffic, hills, street lights, enjoyable scenery, and observations of others exercising all impact our level of physical activity². Regular physical activity is important to build and maintain healthy bones, muscles, and joints and to help reduce the risk of developing heart disease, diabetes, high blood pressure, colon and breast cancer, obesity, and depression and anxiety. Eliminating barriers to physical activity and increasing access to parks and open space and quality recreational facilities and programs increases the likelihood that people will exercise³.

¹ Jackson, Richard. (n.d.). Creating a healthy environment: The Impact of the built environment on the public health. Sprawl Watch Clearinghouse Monograph Series. Retrieved August 27, 2009 from <http://www.sprawlwatch.org/health.pdf>.

² King, AC, et. al. (2000). Personal and environmental factors associated with physical inactivity among different racial-ethnic groups of US middle-aged and older-aged women. *Health Psych*; 19(4):354-364.

³ Kahn, E.B. (2002). The effectiveness of interventions to increase physical activity. *American Journal of Preventative Medicine* 22: 87-88.



Problems with environmental justice are often related to procedural or geographic inequity. Procedural inequity occurs when the planning process is not conducted in a uniform way. An example of this would be conducting public meetings at locations and/or times that make it difficult for certain individuals or groups to participate in a worthwhile fashion. Geographic inequity occurs when undesirable or unhealthy land uses are concentrated within one part of a city, creating a disproportionate burden on the residents in that area. Geographic inequity also refers to a situation in which desirable public amenities are not equitably distributed, leaving portions of a city underserved.

The purpose of this Health and Environmental Justice Element is to identify public health risks and environmental justice concerns and improve living conditions to foster the physical health and well-being of National City's residents. The hope is that the City's commitment to preventative health measures will become evident in decreases in the occurrence of diabetes, asthma, heart disease, cancer, and other physical and emotional ailments. Public health and environmental justice are themes that are tied to all of the General Plan elements, so it is important to cross-reference other sections of this document for a complete picture of National City's efforts to improve health and equality.

The Health and Environmental Justice element is not a state-mandated element. However, by including this element in the General Plan, the City hopes to give prominence to National City's health and environmental justice priorities. The authorization for this optional element is contained within Section 65303 of the California Government Code, which permits local jurisdictions to adopt additional elements beyond the mandatory elements when they relate to the physical development of the jurisdiction.

B. Existing Setting

Most health statistics are not available at the planning area level for this General Plan. The San Diego County Community Health Statistics Unit mainly provides demographic and health data at a regional level. National City is located within the "South Region" of San Diego County, which also includes the communities of Chula Vista, Coronado, South Bay, and Sweetwater. Most of the health information within this section applies to the South Region. However, where available, statistics specific to National City's 91950 zip code are discussed.



RESPIRATORY HEALTH AND AIR QUALITY

There are two main breathing disorders that are tied to environmental air quality that can serve as indicators for the respiratory health of National City: asthma and chronic obstructive pulmonary disease (COPD). Environmental risk factors for both of these conditions include outdoor air pollution and cigarette smoke.

According to 2005/2006 fiscal year (FY) data, overall asthma hospitalization rates for the South Region are just slightly higher than countywide rates (74 persons per 100,000 population versus 70 persons per 100,000 population).⁴ However, children under 17 within National City's 91950 zip code suffer disproportionately from asthma symptoms than children in the rest of San Diego County. According to 2005 data, children's asthma hospitalization rates for National City are approximately 57% higher than the County average (247 children per 100,000 children versus 140 children per 100,000 children)⁵.

According to 2005 data, the South Region has a higher rate of hospitalizations that are attributed to COPD than San Diego County (108.8 per 100,000 versus 95.7 per 100,000)⁶. Figure HEJ-1 identifies COPD hospitalization rates by zip code to provide a better picture of how this disease specifically affects National City⁷. In 2004, National City experienced 200.1 to 300 hospitalizations per 100,000 persons for COPD, which is higher than surrounding communities. Eastern San Diego County is the only other area in the county that shares such a high rate of hospitalizations for COPD.

Hospitalization rates may be higher in certain areas either because there is an actual higher incidence of these disorders in those areas or because there is less adequate management of these disorders, resulting in a greater rate of hospitalization.

Because of the link between respiratory illnesses and air pollution, federal and state clean air standards have been established for common outdoor air pollutants to protect



Asthma – An inflammatory disorder of the airways, which causes attacks of wheezing, shortness of breath, chest tightness, and coughing.

Chronic Obstructive Pulmonary Disease – A breathing disorder that gets worse over time which can cause coughing that produces large amounts of mucus, wheezing, shortness of breath, chest tightness, and other symptoms.

⁴ San Diego Regional Asthma Coalition (2008). San Diego County asthma report card.

⁵ Office of Statewide Health Planning and Development. (2005). Children's asthma hospitalization rates by zip code.

⁶ County of San Diego Health and Human Services Community Health Statistics Unit (2009). County of San Diego Community Profiles by Region and Subregional Area: South Region.

⁷ County of San Diego Health and Human Services Community Health Statistics Unit. (2006). Health Indicator Maps. Retrieved August 31, 2009 from

http://www.sdcounty.ca.gov/hhsa/programs/phs/community_health_statistics/index.html.



Ozone – A gas composed of three oxygen atoms linked together. At ground level, it is formed by chemical reactions of nitrogen oxides (NOx) and volatile organic compounds (VOCs) in the presence of sunlight. NOx and VOC emissions are mostly the result of human activities such as fossil fuel combustion and solvent use. Ozone can cause coughing, throat irritation, pain, burning, or discomfort in the chest when taking a deep breath, and chest tightness, wheezing, or shortness of breath.

public health and the environment. The federal standards, known as National Ambient Air Quality Standards (NAAQS), are established by the Environmental Protection Agency (EPA) pursuant to requirements of the federal Clean Air Act (CAA). Each area of the nation with air pollution levels violating NAAQS are designated as non-attainment areas and must submit a plan outlining the combination of local, state, and federal actions and emission control regulations necessary to bring the area into attainment. San Diego County is currently designated as a non-attainment area for ozone⁸.

In California, the California Air Resources Board (CARB) is responsible for meeting the State requirements of the federal CAA, administering the California CAA and establishing the California Ambient Air Quality Standards (CAAQS). The California CAA, as amended in 1992, requires all air districts in the State to endeavor to achieve and maintain the CAAQS. The CAAQS are generally more stringent than the corresponding federal standards and incorporate additional standards for sulfates, hydrogen sulfide, vinyl chloride, and visibility reducing particles.

Air quality issues are locally regulated by San Diego County's Air Pollution Control District (APCD). The APCD is an extension of the CARB. The APCD has air monitoring stations in downtown San Diego and Chula Vista. There are no air monitoring stations in National City. As such, the measurement of air quality within National City is reflective of a larger region, and it does not measure specific locations (the port, freeways, gas stations, etc.) where local sources could be contributors to higher levels of pollutants.

Table HEJ-1 displays data on how often and by how much the air surrounding National City, measured in downtown San Diego and Chula Vista, violated state and federal ozone laws between 2004 and 2008. Chula Vista exceeded the federal 8-hour standard twice and the state 8-hour standard six times. Downtown San Diego did not exceed the federal standard, but did exceed the state standard once. Both Chula Vista and Downtown San Diego are far below the number of days that exceeded state and federal standards countywide. This is likely because these coastal cities, like National City, benefit from the prevailing eastern wind currents that carry some of the air pollution away from the coast to inland locations such as Alpine and El Cajon.

⁸ San Diego County Air Pollution Control District (2007). Eight Hour Ozone Attainment Plan.

Selected Chronic Disease Medical Encounter Rates, San Diego County by Community

Chronic Obstructive Pulmonary Disease (COPD) Hospitalization Rates, 2004

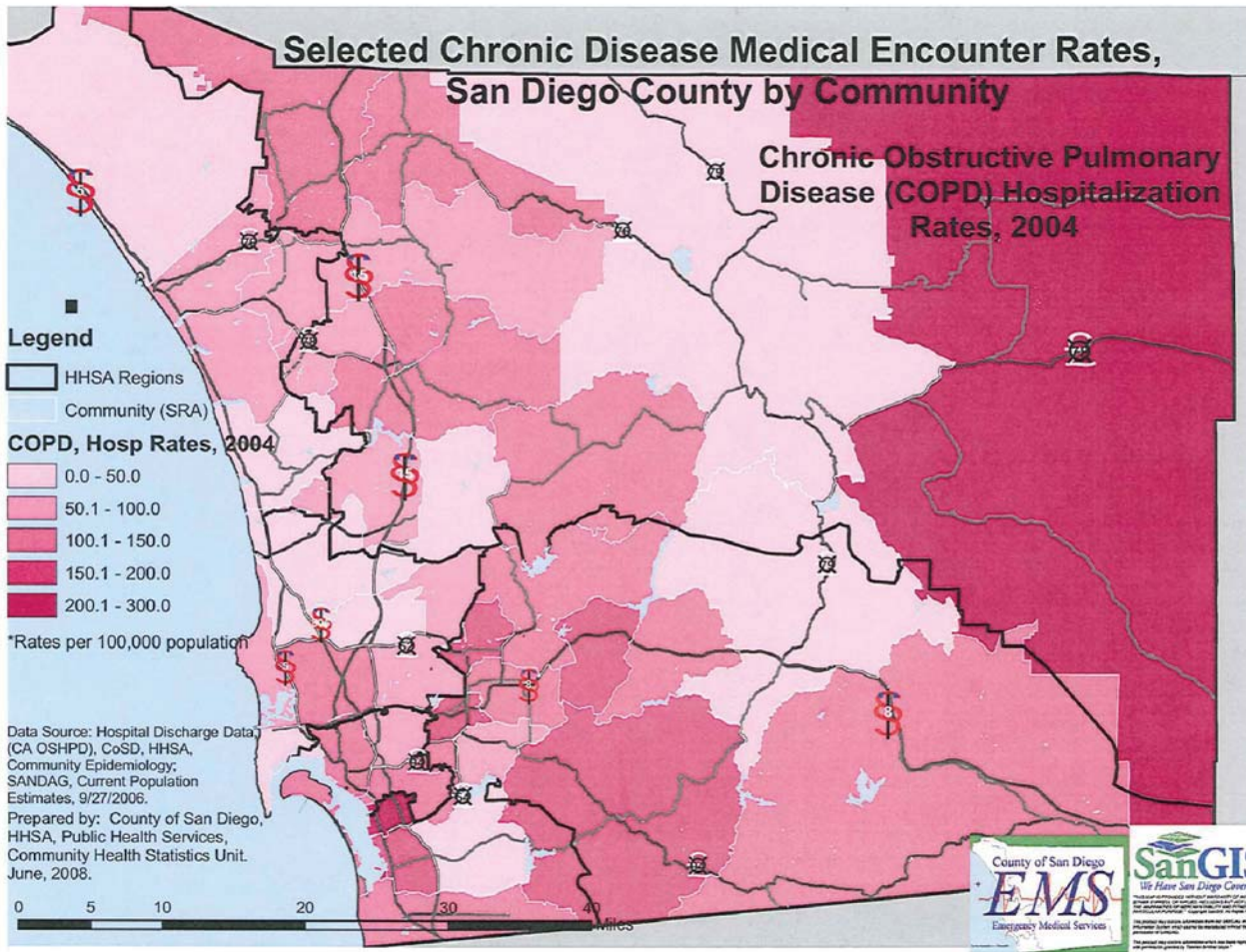

Figure HEJ-1
Chronic Obstructive
Pulmonary Disease (COPD)
Hospitalization Rates, 2004



BACK SIDE OF FIGURE

TABLE HEJ-1
Ozone
Number of Days Exceeding Federal and State Standards (2004-2008)*

Station	# of Days Exceeding Fed 8 hr Stnd >8.4 parts per hundred million (pphm)**					# of Days Exceeding State 8 hr Stnd >7.0 parts per hundred million (pphm)					Max 8 hr Concentration				
	2004	2005	2006	2007	2008	2004	2005	2006	2007	2008	2004	2005	2006	2007	2008
Chula Vista	1	0	0	1	0	State standard adopted in 2006	0	2	4	9	8	7	9	8	
Downtown SD***	0	0	0	0	0		0	0	1	8	7	9	8	9	
Countywide	8	5	14	7	11		68	43	65	10	9	10	9	11	

* Data excludes measurements taken during the 2007 fires, as they emitted huge amounts of pollutants, mainly particulate matter, and led to the area being out of compliance. The event was rare enough that the data from that time was withdrawn from calculation.

** Federal 8 hr standard was revised to >7.5 pphm on March 12, 2008, to become effective March 12, 2009.

*** Downtown San Diego monitoring station was moved in 2005 from 12th Avenue to Beardsley Street. 2004 and 2005 measurements are taken from the 12th Avenue monitoring station.

Source: Air Pollution Control District (2008). Five year air quality summary: 2004-2008. Retrieved August 27, 2009 from <http://www.sdapcd.org/air/reports/smog.pdf>.



Particulate Matter
– A complex mixture of extremely small particles and liquid droplets made up of a number of components including acids, organic chemicals, metals, and soil or dust particles.

Particulate matter (PM) is another pollutant of concern for San Diego County. Like ozone, PM is formed in the air by a chemical reaction and mainly comes from combustion sources like vehicles, diesel engines, and industrial facilities. Smoke from wildfires and dust also contains PM. Once inhaled, PM can affect the heart and lungs and cause serious health effects. Scientists have observed higher rates of hospitalizations, emergency room visits, and doctor's visits for respiratory illnesses or heart disease during times of high PM concentrations. During these periods of high PM levels, scientists have also observed the worsening of asthma symptoms and acute and chronic bronchitis.

There are two categories of PM: PM₁₀ particles, which are less than 10 micrometers in diameter and PM_{2.5} particles, which are less than 2.5 micrometers in diameter.

Table HEJ-2 identifies data regarding PM measurements taken at the San Diego and Chula Vista monitoring stations from 2004 to 2008 for both PM₁₀ and PM_{2.5}. The highlighted cells identify the incidences in which standards were exceeded. According to CARB, most areas of California exceed the current state PM standards from a few to many times each year.

Over the past two decades, air quality in San Diego County has improved significantly due to state and federal regulations controlling emissions from mobile sources of air pollution, such as vehicles, and local controls on emissions from industrial sources, such as factories and power plants, commercial sources, such as gas stations and dry cleaners, and residential sources, such as water heaters and furnaces. The APCD's 2007 Air Quality Management Plan was designed to reduce ozone concentrations to below the level of the federal standard in 2009⁹. The standard has not been met.

⁹ San Diego County Air Pollution Control District (2007). Eight Hour Ozone Attainment Plan.



**TABLE HEJ-2
Particulate Matter Measurements**

Particulate Matter (PM ₁₀) Annual Arithmetic Mean and Maximum 24 hr Sample (2004-2008)*										
Station	Annual Arithmetic Mean Fed Stnd is 50 micrograms/m ³ ** State Stnd is 20 micrograms/m ³					Max 24 hr Sample Fed Stnd is 150 micrograms/m ³ State Stnd is 50 micrograms/m ³				
	2004	2005	2006	2007	2008	2004	2005	2006	2007	2008
Chula Vista	26	27	26	25	26	44	52	51	51	53
Downtown SD***	33	28	24	30	29	68	76	71	55	58
Particulate Matter (PM _{2.5}) Annual Average and Maximum 24 hr Sample (2004-2008)*										
Station	Annual Average Fed Stnd is 15 micrograms/m ³ State Stnd is 12 micrograms/m ³					Max 24 hr Sample Fed Stnd is 35 micrograms/m ³				
	2004	2005	2006	2007	2008	2004	2005	2006	2007	2008
Chula Vista	12	12	11	11	12	33	34	30	46	33
Downtown SD***	14	11	13	12	14	43	32	63	52	42

* The data excludes measurements taken during the 2007 fires.

** EPA revoked the Federal Arithmetic Mean standard for PM10 as of December 17, 2006, due to lack of available evidence linking health problems to long-term coarse particle pollution.

*** Downtown San Diego monitoring station was moved in 2005 from 12th Avenue to Beardsley Street. 2004 and 2005 measurements are taken from the 12th Avenue monitoring station.

Source: Air Pollution Control District (2008). Five year air quality summary: 2004-2008. Retrieved August 27, 2009 from <http://www.sdapcd.org/air/reports/smog.pdf>.

SURROUNDING LAND USES



The majority of land within the planning area located west of I-5 is under the jurisdiction of the San Diego Unified Port District (Port) and the US Navy. Most of the existing land uses located within the Port’s jurisdiction can be classified as marine industrial, which includes activities such as shipping, warehousing, manufacturing, and distribution. The Port Master Plan (2010) designates most of the 250 land acres in its National City Bayfront Planning Area for marine-related industrial and marine terminal uses.



On-going and planned uses west of I-5; therefore, pose undesirable impacts on non-industrial and sensitive land uses throughout the planning area. Industrial uses are responsible for the generation of point and non-point source emissions. Distribution activities generate a substantial amount truck traffic that contribute to high levels of diesel emissions and air quality concerns in other areas of the city. Additionally, the heavy concentration of marine-related and



military facilities has created substantial barriers to public coastal access across most of National City’s bayfront.

PUBLIC HEALTH AND FITNESS

Physical Activity



Regular physical activity is critically important for the health and well-being of people of all ages. Millions of Americans suffer from health problems that can be prevented or improved through regular exercise; these problems include: heart disease, obesity, diabetes, stress, and depression¹⁰. According to the San Diego County Health and Human Services Community Health Statistics Unit, there is a low percentage of people (18 years of age and older) engaging in moderate and vigorous physical activity within both the South Region and San Diego County as a whole. Refer to Table HEJ-3.

**Table HEJ-3
Physical Activity and Exercise (Adults 18+ yrs)***

Region	Walked for Transport or Fun/Exercise**	No Physical Activity**	Engaged in Moderate Physical Activity**	Engaged in Vigorous Physical Activity**
South Region				
2005	79%	11%	15%	18%
2007	Data not avail.	13%	14%	20%
San Diego County				
2005	79%	10%	16%	15%
2007	Data not avail.	14%	17%	20%

*% is proportion of people who replied with indicated response to question. Respondents were asked a series of questions related to walking and physical activity to determine whether level is none, some, moderate, or vigorous over a seven day timeframe.

** Percentages are rounded to the nearest whole number.

Source: UCLA Center for Health Policy Research, California Health Interview Survey, <http://www.chis.ucla.edu/> (accessed 5/2009); SANDAG, Current Population Estimates, 8/06, 4/08.

Prepared by County of San Diego (CoSD), Health & Human Services Agency (HHSA), Public Health Services (PHS), Community Health Statistics, 6/26/2009.

To understand physical fitness levels among children, Table HEJ-4 identifies the percentage of 5th, 7th, and 9th graders in National City meeting the healthy fitness zone for six out of six physical fitness indicators: aerobic capacity, body composition, abdominal strength, trunk extensor strength,

¹⁰ U.S. Department of Health and Human Services (2002). Physical activity fundamental to preventing disease. Retrieved August 28, 2009 from <http://aspe.hhs.gov/health/reports/physicalactivity/>.



upper body strength, and flexibility. There is a lower percentage of fifth graders, attending public schools in National City, who meet fitness standards in comparison to San Diego County and California. Seventh and ninth grade scores are better than County and State scores for the reporting academic year (2008-2009).

TABLE HEJ-4
National City Students Meeting the Healthy Fitness Zone for
6 out of 6 Physical Fitness Areas (2008-2009)*

School	5 th Grade**	7 th Grade**	9 th Grade**
Sweetwater High School	--	--	45%
National City Middle School	--	42%	--
Granger Junior High		43%	53%
Olivewood Elementary	18%	--	--
Las Palmas Elementary	12%	--	--
Kimball Elementary	28%	--	--
Palmer Elementary	18%	--	--
Harbison Elementary	16%	--	--
John Otis Elementary	25%	--	--
Central Elementary	11%	--	--
El Toyon Elementary	28%	--	--
Lincoln Acres Elementary	22%	--	--
For Comparison Purposes:			
San Diego County	31%	38%	42%
State of California	29%	34%	38%

Source: California Department of Education Dataquest. Retrieved April 15, 2010 from: <http://data1.cde.ca.gov/dataquest/>

*The physical fitness test is required to be administered to students in grades 5, 7, and 9 only.

**Percentages are rounded to the nearest whole number.



Heart Disease – A broad term that includes more specific heart conditions such as coronary heart disease which can lead to heart attacks and other serious conditions. Heart disease is the leading cause of death for both men and women in the United States.

Overweight – A condition in which a person's body mass index is between 25 and 29.99.

Obesity – A condition in which a person's body mass index is 30 or higher.

Physical inactivity is one of the main risk factors in developing heart disease, along with tobacco use, obesity, excessive alcohol use, heredity, and diets high in salt, saturated fats, and cholesterol. According to the County of San Diego Health and Human Services Community Health Statistics Unit, in 2004, National City experienced a relatively high rate of death from coronary heart disease (191 deaths per 100,000 population compared to 133 deaths per 100,000 population countywide).

Obesity is a major risk factor for cardiovascular disease, certain types of cancer, and Type 2 diabetes¹¹. Exercise and regular physical activity can help to alleviate overweight and obese conditions. Highly walkable neighborhoods have been associated with a decrease in weight and waist size for individuals who increased their levels of physical activity during a one-year period¹². In 2007, the percentage of overweight and obese individuals was slightly higher in the South Region than county-wide (22% of individuals were overweight in the South Region compared to 18% countywide and 25% of individuals were obese compared in the South Region compared to 22% countywide)¹³.

Diabetes is a disease in which the body does not produce or properly use insulin. Insulin is a hormone that is needed to convert sugar, starches, and other food into needed energy. The more fat tissue a person has, the less sensitive his or her body is to insulin. As a result, there is a strong link between Type 2 diabetes and obesity. A healthy diet and regular physical activity is crucial to maintaining a healthy weight and reducing the risk for diabetes. In 2004, National City had the highest rate of deaths from diabetes in San Diego County (41 persons per 100,000 population compared to 18 persons per 100,000 population countywide)¹⁴. Refer to Figure HEJ-2.

A growing body of research shows that exercise also can help improve the symptoms of emotional ailments, such as stress and depression. Exercise can help prevent a relapse after treatment for depression. It may take at least 30 minutes of exercise a day for at least three to five days a

¹¹ Centers for Disease Control and Prevention (2009). Overweight and obesity. Retrieved August 31, 2009 from http://www.cdc.gov/heartdisease/risk_factors.htm.

¹² Oregon Research Institute (2009). Fast-food density and neighborhood walkability linked to residents' weight and waist side. Science Daily. Retrieved August 31, 2009 from <http://www.sciencedaily.com/releases/2009/03/090303161431.htm>.

¹³ County of San Diego Health and Human Services Community Health Statistics Unit (2009). County of San Diego Community Profiles by Region and Subregional Area: South Region.

¹⁴ County of San Diego Health and Human Services Community Health Statistics Unit. (2006). Health Indicator Maps. Retrieved August 31, 2009 from http://www.sdcountry.ca.gov/hhsa/programs/phs/community_health_statistics/index.html.

Selected Chronic Disease Medical Encounter Rates, San Diego County by Community

Diabetes Death Rates, 2004

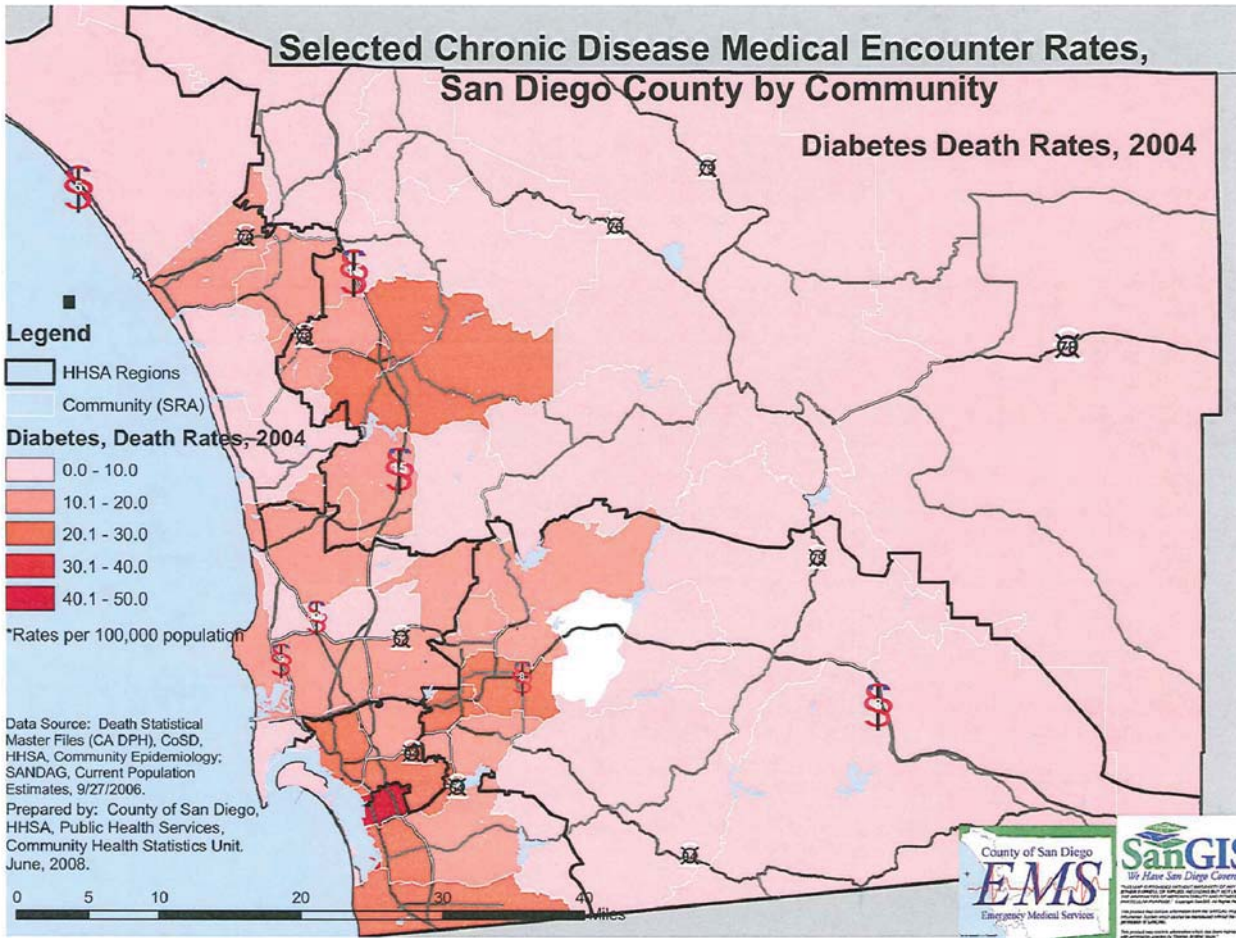

Figure HEJ-2
Diabetes Deaths
San Diego County



BACK SIDE OF FIGURE



week to significantly improve depression symptoms. However, smaller amounts of activity, as little as 10 to 15 minutes at a time, can improve mood in the short term¹⁵.

In addition to improving mental health, management of stress and depression is important to prevent serious physical health problems, such as heart disease. There are linkages between heart disease and the factors that often cause stress. There also are links between heart disease and depression. For instance, women who are depressed are twice as likely to develop heart disease as those who are not¹⁶.

In 2007, the percentage of adults within the South Region who sought out professional help for a mental or emotional condition was lower than in San Diego County (14% in the South Region compared to 21% countywide)¹⁷. This does not necessarily indicate that there are fewer people in the South Region experiencing emotional distress. It is possible that people in the South Region are just less likely to obtain help from a counselor due to various economic, cultural, or access constraints.

Healthy Foods

The availability of healthy food options, including fresh produce, at stores and farmers' markets, may correlate with a higher consumption of fruits and vegetables, which in turn, can alleviate the prevalence of excess weight and obesity. A high density of neighborhood fast food outlets (formula restaurants) has been shown to be associated with weight gain and an increase in waist size among residents who frequent those establishments¹⁸. Within National City, there are approximately twice as many fast food and convenience stores as there are general grocery and fruit and vegetable markets¹⁹.

A major factor affecting access to healthy foods is an individual's or family's level of income. High calorie foods tend to be the least expensive and most resistant to

¹⁵ Mayo Clinic (2007). Depression and anxiety: Exercise eases symptoms. Retrieved August 31, 2009 from <http://www.mayoclinic.com/health/depression-and-exercise/MH00043>.

¹⁶ Sutter Health (2008). Stress and depression. Retrieved August 31, 2009 from http://hearts.sutterhealth.org/women/risk/wha_depression.html.

¹⁷ County of San Diego Health and Human Services Community Health Statistics Unit (2009). County of San Diego Community Profiles by Region and Subregional Area: South Region.

¹⁸ Fuzhong Li, PhD; Peter Harmer, PhD, MPH; Bradley J. Cardinal, PhD; Mark Bosworth, MS; Deb Johnson-Shelton, PhD. (2009). Obesity and the Built Environment: Does the Density of Neighborhood Fast-Food Outlets Matter? *American Journal of Health Promotion*. Vol. 23, No. 3.

¹⁹ California Department of Public Health (2008). California Nutrition Network Map. Retrieved August 31, 2009 from <http://cnngis.org/viewer.aspx>.



inflation, which partially explains why the highest rates of obesity continue to be observed in groups with the most limited economic means²⁰. According to the US Census, in 2000, 22% of National City's population was living in poverty compared to 12% countywide.

The county-administered Supplemental Nutrition Assistance Program (SNAP) seeks to provide assistance relative to food costs. According to the United States Department of Agriculture (USDA), the San Diego County participation rate in the SNAP ranks the lowest in the nation among urban centers. Of those eligible to receive SNAP benefits, only 29% are doing so²¹. Although food stamp data are not available at the city level, based on County statistics, it is highly likely that there are far more people eligible to receive benefits in National City than who actually participate in the program. The San Diego County has attributed its low participation rates to a lack of awareness of food stamp eligibility rules and dissatisfaction with the eligibility process.

Access to Health Care

The availability of, and access to, health care facilities plays a large role in the preservation and maintenance of good public health and the prevention of morbidity and hospitalizations. National City contains six primary care facilities, five long term care facilities, and one hospital. All appear to be well served by vehicular routes and public transport (refer to Figure HEJ-3). Since having medical insurance influences whether or not one visits a medical professional, it is important to note the percentage of the population that is currently insured. In 2007, the percentage of currently insured adults aged 18-64 within the South Region was 83%, which mirrored that of the county¹⁵.

Lead Based Paint

Structures constructed prior to 1978 have the propensity to contain paint that has high levels of lead. Approximately 85 percent of the residential dwelling units in the City were constructed prior to 1980²². Lead-based paint is not a hazard when it is in good condition, but exposure to lead often occurs when paint is aging, peeling, or being removed. Lead exposure can cause nervous system and kidney

²⁰ Reuters Health (2008). Healthy food getting more expensive. Retrieved August 31, 2009 from <http://www.reuters.com/article/healthNews/idUSPAR27349420080102>.

²¹ Food research and action center (2008). Food stamp access in urban America: A city by city snapshot. Retrieved September 3, 2009 from <http://frac.org/pdf/urbanfoodstamps08.pdf>.

²² U.S. Census Bureau, American FactFinder. (2000.) Census 2000, Summary File 3. Retrieved May 3, 2010 from: <http://factfinder.census.gov/home/en/datanotes/expsf3.htm>.

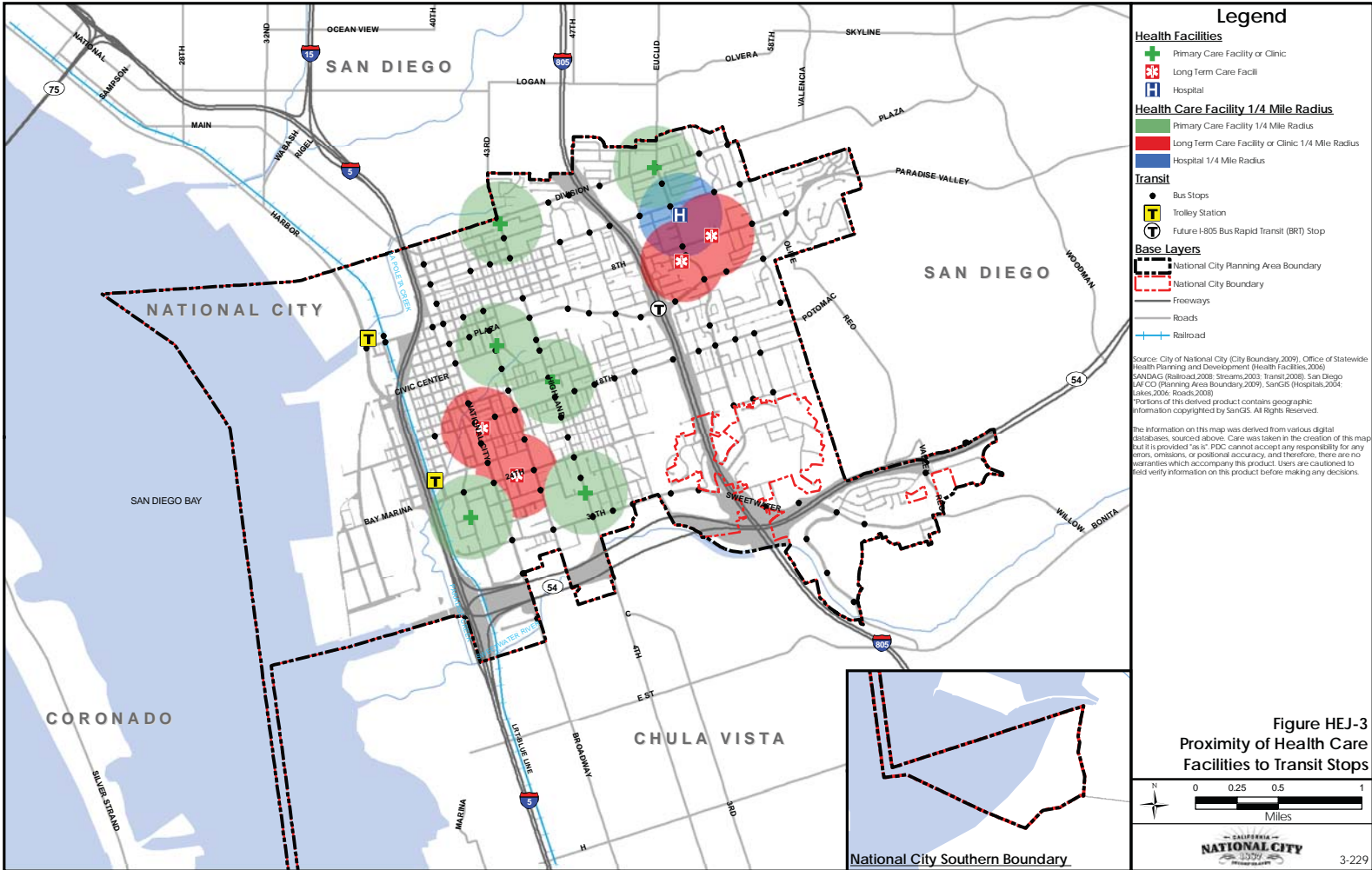

BACK SIDE OF FIGURE



damage (among a host of other physical problems) in children. Exposure to high levels of lead can lead to serious health problems such as seizures. Lead exposure also can be dangerous for adults, with impacts ranging from increased chances of illness during pregnancy to nerve disorders.



Approximately 13,348 housing units were constructed prior to 1980 in National City. Approximately 589 of these units are at high risk for containing lead based paint hazards. Through grants and public/private participation a total of 115 units have been mitigated from a lead based paint perspective as of 2008²³. As of the writing of this document, the City does not have a program to address residential lead paint issues. It is anticipated that a Housing Rehabilitation Program, slated to begin in 2010, will include a component to address residential lead based paint issues.

C. Citywide Goals and Policies

ENVIRONMENTAL JUSTICE

Refer to the Education and Public Participation Element for additional policies related to community outreach and involvement.

Goal HEJ-1: Meaningful and effective participation, promotion of community capacity building, and fair treatment of all segments of the public in the process of creating a healthy environment and developing, adopting, implementing, and enforcing environmental laws, regulations, and policies.

Policy HEJ-1.1: Facilitate the involvement of community residents, businesses, and organizations in the development, adoption, and implementation of community health initiatives and consider their input throughout the decision-making process.

Policy HEJ-1.2: Consider environmental justice issues as they are related to potential health impacts associated with land use decisions, including enforcement actions, to reduce the adverse health effects of hazardous materials, industrial activities, and other undesirable land uses, on residents regardless of age, culture, ethnicity, gender, race, socioeconomic status, or geographic location.

Policy HEJ-1.3: Consider environmental justice issues as they are related to the equitable provision of desirable public amenities such as parks, recreational facilities,

²³ City of National City (2008). Closeout of Lead Hazard Control (LHC) Grant - CALHB0238-03 Final Report.



community gardens, and other beneficial uses that improve the quality of life.

Policy HEJ-1.4: Address health issues in National City with the public during the annual review of the General Plan.

Policy HEJ-1.5: Assure potentially affected community residents that they have opportunities to participate in decisions that affect their environment and health, and that the concerns of all participants involved will be considered in the decision-making process.

Policy HEJ-1.6: Hold meetings and workshops at times and locations that are convenient for community members to attend, especially those that may be directly affected by a particular decision.

Policy HEJ-1.7: Apply environmental protection measures equally among geographic and socioeconomic sectors of the City.

Related Policies from Other Elements:

Land Use:

LU-3.2: Prevent the intrusion of new incompatible land uses and environmental hazards into existing residential areas and phase out existing non-conforming uses.

LU-3.6: Prohibit the establishment of new residential and other sensitive land uses near industrial land uses and within the Harbor District (unless proposed as part of a mixed-use development adjacent to the 8th Street Trolley stop) and buffer existing residential uses and other sensitive land uses from industrial uses, while protecting and enhancing visitor-serving, commercial, retail, industrial, working-waterfront, and maritime related job-producing industries.

LU-8.5: Update the capital improvement program for the improvement of existing public facilities and the development of new facilities and plan for the equitable distribution of infrastructure improvements and public facilities and services considering both number/size and access/distance to facilities.

Circulation:

C-1.3: Require new development and redevelopment to provide good internal circulation facilities that meets the



needs of walkers, bicyclists, children, seniors, and persons with disabilities.

C-1.4: Require new development and redevelopment to apply universal design standards.

Safety:

S-7.7: Work with property owners and lead agencies to reduce soil contamination from industrial operations and other activities that use, produce, or dispose of hazardous or toxic substances.

S-8.1: Promote the clean-up and reuse of contaminated sites and prioritize remediation and redevelopment of brownfield sites within and adjacent to residential and mixed-use areas.

S-8.3: Maintain an inventory of permitted and clean-up sites and monitor future uses at those locations. Require appropriate mitigation and clean-up of sites that are known to contain toxic materials as a condition of allowing reuse.

Open Space and Agriculture:

OS-5.1: To the extent feasible, distribute parks and recreational facilities equally throughout National City's neighborhoods, with a focus on neighborhoods that are currently underserved from a public recreation perspective.

Education and Public Participation:

E-7.2: Utilize diverse media, technology, and communication methods to convey information to the public.

E-7.6: Expand efforts to reach out to and provide meaningful involvement opportunities for low-income, minority, disabled, children and youth, and other traditionally underrepresented citizens in the public participation process and encourage non-traditional communication methods to convey complex ideas in an easily understandable manner.

E-7.7: Periodically review the effectiveness of the procedures and strategies used to solicit public input and develop outreach processes and methodologies tailored to the needs of the community.

E-7.9: Initiate outreach efforts as early as possible in the decision-making process, before significant resources have been invested in a particular outcome and ensure that



materials are distributed far enough in advance of meetings, workshops, and hearings to allow sufficient time for review and comment.

E-7-10: Provide adequate translation or interpretation services for documents and public meetings, as resources allow.

Why is this important?

Everyone deserves to live in a community where every body is treated fairly and has an equal opportunity to be healthy. When environmental justice is achieved, it leads to a condition where environmental risks and hazards and investments and benefits are equally distributed with a lack of discrimination; where access to environmental investments, benefits, and natural resources are equally distributed; and where access to information, participation in decision making, and access to justice in environment-related matters are enjoyed by all.

Sensitive Land Uses – Land uses where segments of the population most susceptible to poor air quality (i.e., children, the elderly, and those with pre-existing serious health problems affected by air quality) are most likely to spend time, including schools and schoolyards, parks and playgrounds, day care centers, nursing homes, hospitals, and residential communities. (California Air Resources Board)

RESPIRATORY HEALTH AND AIR QUALITY

Goal HEJ-2: Improved air quality to protect human and environmental health and minimized air quality impacts on sensitive population groups.

Policy HEJ-2.1: Avoid land use conflicts by ensuring residential, public assembly, and other sensitive land uses are adequately buffered from industrial land uses that may pose a threat to human health, where feasible.

Policy HEJ-2.2: Encourage existing stationary sources of emissions to use feasible measures to minimize emissions that could have potential impacts on air quality and incentivize non-conforming uses to relocate to appropriate industrial zones if currently impacting sensitive land uses.

Policy HEJ-2.3: Avoid siting new sensitive land uses within 500 feet from the centerline of a freeway, unless such development contributes to smart growth, open space, or transit-oriented goals, in which case the development shall include feasible measures such as separation/setbacks, landscaping, barriers, ventilation systems, air filters/cleaners, and/or other effective measures to minimize potential impacts from air pollution.



Policy HEJ-2.4: Require new sensitive land uses to include feasible measures such as separation/setbacks, landscaping, barriers, ventilation systems, air filters/cleaners, and/or other effective measures to minimize potential impacts from air pollution.

Policy HEJ-2.5: Encourage existing sensitive land uses to include feasible measures such as separation/setbacks, landscaping, barriers, ventilation systems, air filters/cleaners, and/or other effective measures to minimize potential impacts from air pollution.



Refer to the Conservation and Sustainability Element for additional policies related to reducing emissions and improving air quality.

Policy HEJ-2.6: Consider air quality impacts, including cumulative impacts, from existing and new development when making land use decisions and limit the number of industrial facilities or uses to prevent cumulative air pollution impacts.

Policy HEJ-2.7: Designate truck routes that avoid sensitive land uses, where feasible.

Policy HEJ-2.8: Encourage smoke-free workplaces, multi-family housing, parks, and other outdoor gathering places to reduce exposure to second-hand smoke.



Refer to the Circulation Element for additional policies related to transportation planning.

Policy HEJ-2.9: Request lead and responsible agency consultation on land use and transportation planning, design, and implementation projects to insure that feasible measures are included to minimize potential impacts on the city from air pollution.

Policy HEJ-2-10: Distribute information about best practices to reduce and/or eliminate sources of indoor air pollution.

Related Policies from Other Elements:

Land Use:

Policy LU-1.2: Concentrate commercial, mixed-use, and medium to high density residential development along transit corridors, at major intersections, and near activity centers that can be served efficiently by public transit and alternative transportation modes.

Policy LU-1.5: Consider the effects of land use proposals and decisions on the region and efforts to maintain a jobs-housing balance.

Policy LU-1.6: Enable residents to reduce their commutes by supporting telecommuting, satellite work centers, and home



occupations that are compatible with adjacent or surrounding properties.

Policy LU-2.1: Provide for housing near jobs, transit routes, schools, shopping areas, and recreation to discourage long commutes; promote public transit, walking, and biking; and lessen traffic congestion.

Policy LU-3.7: Limit impacts from industrial or mixed-uses by establishing performance standards to regulate noise, glare, vibrations, odor, lighting, air pollution, and other potential disturbances.

Circulation:

Policy C-1.1: Allow, encourage, and facilitate transit-oriented development, mixed-use, and infill projects in appropriate locations to reduce vehicular trips, especially near the 8th Street and 24th Street trolley stops, the future South Bay Bus Rapid Transit Station (BRT), and along major transportation corridors such as 8th Street, Highland Avenue, Plaza Boulevard, and 30th Street/Sweetwater Road.

Policy C-4.1: Encourage businesses to provide flexible work schedules for employees.

Policy C-4.2: Encourage employers to offer shared commute programs and/or incentives for employees to use transit.

Policy C-4.3: Require new uses to provide adequate bicycle parking and support facilities.

Policy C-4.4: Encourage carpooling and other shared commute programs.

Policy C-4.5: Encourage the use of alternative transportation modes.

Policy C-4.6: Prioritize attention to transportation issues around schools to reduce school-related vehicle trips.

Policy C-4.7: Seek opportunities to reduce vehicle trips before requiring physical roadway improvements.

Conservation and Sustainability:

Policy CS-1.1: Develop and adopt new or amended regulations or programs that address:



- Sustainable and efficient land use patterns to reduce vehicular trips and preserve open space;
- Improving energy efficiency, especially in the transportation sector and buildings and appliances;
- Reducing the urban heat island effect through sustainable design and building practices, as well as planting trees (consistent with habitat and water conservation policies) for their many environmental benefits, including natural carbon sequestration;
- Reducing waste by improving management and recycling programs.

Policy CS-1.4: Continue to evaluate and manage the City’s facilities (including its vehicle fleet) and operations to reduce emissions.

Policy CS-7.1: Promote the use of green building practices in new and existing development to maximize energy efficiency and conservation.

Policy CS-7.7: Encourage LEED certification for all new municipal, commercial, and industrial buildings in the city.

Why is this Important?

National City suffers disproportionately from respiratory disorders associated with air quality issues compared to other parts of San Diego County. The above goal and policies are intended to reduce exposure to poor air quality by separating sensitive receptors from significant sources of air pollution; reducing emissions; incorporating design features that minimize air quality impacts into new development; considering cumulative air quality impacts when making land use decisions; and advising other jurisdictions on land use decisions that could affect National City residents.



Refer to the Open Space and Agriculture Element for additional policies related to recreation.

Refer to the Circulation Element for policies related to pedestrian and bicycle circulation.

PHYSICAL ACTIVITY

Goal HEJ-3: Safe and accessible physical activities to meet the needs of all segments of the community.

Policy HEJ-3.1: Encourage walking and bicycling as daily physical activities by providing conveniently located daily goods and services and recreational facilities and programs within a comfortable walking or biking distance from homes.



Universal Design –
A user-friendly approach to design in the living environment where people of any culture, age, size, weight, race, gender and ability can experience an environment that promotes their health, safety and welfare today and in the future. (Universal Design Alliance)



Policy HEJ-3.2: Identify and eliminate, where feasible, barriers to outdoor physical activity, such as damaged, incomplete, blocked, or littered sidewalks and bike paths, lack of safe street crossings and direct connections, excessive speeding, insufficient lighting, incidence or perception of crime, and lack of landscaping and shade trees along streets.

Policy HEJ-3.3: Improve access to bicycles, helmets, and related equipment for lower income families.

Policy HEJ-3.4: Apply universal design principles in the design and review of development and redevelopment projects, where feasible.

Policy HEJ-3.5: Raise awareness about the importance of healthy behaviors and physical fitness to overall well-being.

Related Policies from Other Elements:

Land Use:

Policy LU-2.1: Provide for housing near jobs, transit routes, schools, shopping areas, and recreation to discourage long commutes; promote public transit, walking, and biking; and lessen traffic congestion.

Policy LU-2.4: Provide additional recreational open space areas and connect these areas to trails, bikeways, pedestrian corridors, and other open space networks, where feasible.

Policy LU-4.2: Promote the design of complete neighborhoods that are structured to be family-friendly, encourage walking, biking, and the use of mass transit, foster community pride, enhance neighborhood identity, ensure public safety, improve public health, and address the needs of all ages and abilities.

Policy LU-9.1: Design developments along mixed-use and “community corridors” for the comfort and enjoyment of pedestrians and bicyclists. This includes features such as street trees, placing buildings close to the street, de-emphasizing parking lots and garages, limited driveway cuts, traffic-calming features, clearly defined street crossings, adequate lighting, and street furnishings where appropriate.

Policy LU-9.4: Encourage an overall high quality streetscape design, where feasible, that promotes narrow roadways; bike lanes; on-street parking; minimal curb cuts; enhanced



crosswalks; appropriate sidewalk widths; landscaped medians and parkways; street trees, planters, and wells; street lighting; street furniture; wayfinding; enhanced paving; public art; and other features that contribute to the desired character for National City, where appropriate.

Circulation:

Policy C-2.2: Enhance connectivity by eliminating gaps and barriers in roadway, bikeway, and pedestrian networks.

Policy C-2.6: Enhance the quality of life in the City’s neighborhoods and minimize impacts on schools, hospitals, convalescent homes and other sensitive facilities through the implementation of traffic calming measures in these areas to reduce vehicle speeds and discourage cut-through traffic.

Policy C-2.8: Implement road diets, where appropriate, as a means to improve safety, increase efficiency of pick-up and drop-off operations at schools, and provide greater separation between pedestrians and vehicles.

Policy C-4.3: Require new uses to provide adequate bicycle parking and support facilities.

Policy C-8.1: Provide connectivity of wide, well-lit walking environments with safety buffers between pedestrians and vehicular traffic, when feasible.

Policy C-8.2: Require new development and redevelopment to incorporate pedestrian-oriented street designs that provide a pleasant environment for walking.

Policy C-8.3: Identify and implement necessary pedestrian improvements with special emphasis on providing safe access to schools, parks, community and recreation centers shopping districts, and other appropriate facilities.

Policy C-8.4: Promote walking as the primary travel mode to schools.

Policy C-8.5: Improve pedestrian safety at intersections and mid-block crossings.

Policy C-8.6: Reduce architectural barriers that restrict full movement and access by less mobile segments of the population consistent with the Americans with Disabilities Act.



Policy C-8.7: Apply universal design standards to the pedestrian system.

Policy C-8.8: Provide a continuous pedestrian network within and between neighborhoods to facilitate pedestrian travel free from major impediments and obstacles.

Policy C-9.1: Expand and improve the bikeway system and facilities by establishing bike lanes, separated paths, and bicycle storage facilities at major destinations.

Policy C-9.2: Require new development and redevelopment to provide safe, secure bicycle parking facilities.

Policy C-9.3: Require new development and redevelopment to provide connections to existing and proposed bicycle routes, where appropriate.

Policy C-9.4: Encourage existing businesses and new development or redevelopment projects to promote bicycling and provide bike rack facilities, personal lockers, and shower rooms.

Policy C-9.5: Encourage bicycling through education and promotion programs in conjunction with the local school districts.

Policy C-9.6: Keep abreast of bicycle facility innovations in other cities and regions, and seek to incorporate these into the bicycle network.

Open Space and Agriculture:

Policy OS-5.2: Strive to meet or exceed and maintain a park to population ratio of 4.75 acres per 1,000 residents, as fiscal resources allow.

Policy OS-5.3: Encourage the development and maintenance of recreational facilities by the private and non-profit sectors that complement and supplement the public recreational system.

Policy OS-5.4: Require new residential development projects, including mixed-use projects with residential components, to provide adequate park/open space, pay an in-lieu fee, and/or form a maintenance assessment district in order to help meet the City's park standards.

Policy OS-5.5: Develop standards for the design of park facilities and landscaping, which enhance and preserve



natural site characteristics as appropriate and to minimize maintenance demands.

Policy OS-5.6: Encourage the use of best management practices to achieve long-term energy efficiency and water and resource conservation, including the incorporation of xeriscape, renewable energy sources, green building and low-impact development practices for public and private park improvements.

Policy OS-5.7: Support the redevelopment of the National City Golf Course with public recreational facilities, a community garden, and other accessory or supporting uses.

Policy OS-5.8: Promote the use of utility corridors, reclaimed solid waste facilities, abandoned railroad rights of way, and similar surplus lands as parks.

Policy OS-5.9: Identify appropriate areas for street conversions that would allow for the development of neighborhood parks and community gardens.

Policy OS-5.10: Work with local school districts to provide joint use of school properties as neighborhood parks and recreational centers.

Policy OS-5.11: Establish and enforce maintenance standards for all park and recreational facilities.

Policy OS-5.12: Provide and promote a variety of high quality active and passive recreation programs that meet the needs of and benefit the community.

Policy OS-5.13: Encourage involvement by the non-profit and private sectors in the development, administration, and execution of recreational programs.

Policy OS-6.1: Work with the Port District in the maintenance and improvement of access points to the Sweetwater River and San Diego Bay.

Policy OS-6.2: Evaluate opportunities to improve public access to Paradise Creek and Las Palmas Creek.

Policy OS-7.1: Work with other agencies including the County of San Diego and the City of Chula Vista to allow for the integration of the City's trails with other local, regional, and state trail systems.



Policy OS-7.2: Encourage the creation of connected paseos and trails between community activity areas and schools and consider opportunities to enhance them with kiosks and rest stations.

Policy OS-7.3: Work with utility owners and operators to promote the use of utility easements and corridors as trail corridors, where feasible.

Policy OS-7.4: Where feasible, create and implement non-motorized paths along creeks, rivers, and waterfronts, with a focus on linking to existing pathways.

Why is this important?

The more convenient and comfortable a place is to walk or bike, the more likely an individual is to achieve the recommended amount of daily exercise. Access to parks, trails, and recreation facilities can significantly increase levels of physical activity. Any reduction in vehicle miles traveled also creates corresponding reductions in air pollution, traffic volumes, noise, and safety impacts.

Healthy Food Supply – Provides (1) a minimum of 5,000 square feet of retail space for a general line of food and non-food products intended for home preparation, consumption, and utilization (2) at least 50% of a general consumption line of food products intended for home preparation, consumption, and utilization (3) at least 30% of retail space for perishable goods that include dairy, fresh produce, fresh meats, poultry, fish, and frozen foods (4) at least 500 square feet of retail space for fresh produce. (San Diego County Health and Human Services)

HEALTHY FOODS

Goal HEJ-4: Convenient access to fresh and healthy foods, water, fruits, and vegetables for all segments of the community.

Policy HEJ-4.1: Prioritize healthy food supplies in economic development efforts, especially in areas where a healthy food supply, farmer’s market, or community garden is not located within a half to a quarter mile away.

Policy HEJ-4.2: Encourage the development of healthy food establishments in areas with a high concentration of fast food establishments, convenience stores, and liquor stores.

Policy HEJ-4.3: Encourage and facilitate public or private shuttle systems to transport customers to grocery stores and other sources of healthy foods.

Policy HEJ-4.4: Encourage the development of convenient and accessible community gardens and other sources of healthy foods in appropriate zones and within each neighborhood, where feasible.



Mobile Health Food Market – A truck that delivers groceries to residences and/or sells healthy foods/meals curbside.

 Refer to the Open Space and Agriculture Element for additional policies related to urban agriculture and community gardens.

Community Supported Agriculture (CSAs) – Sometimes referred to as "Subscription Farms" because the consumer buys a subscription from a farmer for a set price to receive fresh produce on a weekly or bi-weekly basis usually delivered to your home or business. (San Diego County Farm Bureau)

Policy HEJ-4.5: Encourage new development and redevelopment to include a healthy food supply or edible garden, or be located within a quarter to a half mile of a healthy food supply, where feasible and appropriate.

Policy HEJ-4.6: Encourage and facilitate the establishment and operation of a farmer’s market(s), farm stands, ethnic markets, mobile health food markets, and convenience/corner stores that sell healthy foods including fresh produce.

Policy HEJ-4.7: Require new development to provide and maintain fresh drinking water fountains, where feasible and appropriate.

Policy HEJ-4.8: Inform low income families and people experiencing homelessness about food assistance programs.

Policy HEJ-4.9: Assess and plan for local food processing, wholesaling, and distribution facilities to connect local agriculture to markets such as retailers, restaurants, schools, hospitals, and other institutions and encourage these markets to carry and serve locally grown or harvested foods.

Policy HEJ-4.10: Explore opportunities for Community-Supported Agriculture within the community.

Goal HEJ-5: Improved eating habits among all segments of the community.

Policy HEJ-5.1: Promote messages regarding healthy eating habits and food choices.

Policy HEJ-5.2: Encourage food-service establishments to post nutritional information, comply with dietary guidelines, eliminate the use of trans fats, and serve locally-grown foods.

Policy HEJ-5.3: When served at City-sponsored events, provide food consistent with health-oriented dietary guidelines, including water and fresh fruit and/or vegetables.

Policy HEJ-5.4: Discourage unhealthy fast food outlets from locating near schools.



Related Policies from Other Elements:

Land Use:

Policy LU-2.5: Encourage the establishment of community farms and gardens.

Open Space and Agriculture:

Policy OS-3.1: Allow for community and private gardens as areas where residents can plant and grow fruit and vegetables and ornamental gardens that can be a source of pride and beauty in the neighborhood.

Policy OS-3.2: Encourage the development of community gardens in conjunction with school sites as an educational resource.

Policy OS-3.3: Encourage the development of unused land such as portions of parks and utility right of ways to be converted to productive space for growing food.

Policy OS-3.4: Support private and institutional gardens and explore additional opportunities for partnerships and collaboration.

Policy OS-3.5: Identify potentially feasible site locations for urban agriculture, including locations for street conversions, and identify links between them.

Policy OS-3.6: Explore and encourage opportunities for roof-top gardens, especially for large, flat roofed industrial, commercial, and institutional buildings.

Policy OS-3,7: Pursue available grants and other funding sources for urban agriculture and community gardens.

Policy OS-3.8: Maintain an on-going dialogue with the community to ensure that its needs are being addressed by urban agriculture endeavors.

Policy OS-3.9: Ensure that community gardens and other urban agricultural resources are accessible to members of all demographic groups within the community, including minorities, seniors, children and persons with disabilities.

Policy OS-3.10: Identify appropriate locations for a farmer's market(s) and farm stands.



Policy OS-3.11: Explore opportunities for the planting of fruit trees and gardens in the public right-of-way, where feasible.

Policy OS-3.12: Encourage the use of best practices for community farming and neighborhood gardening that eliminates or reduces the use pesticides, herbicides, chemical fertilizers, use of gas powered equipment, and encourages composting.

Policy OS-3.13: Strive to meet or exceed and maintain a community garden to population ratio of 0.77 acres per 1,000 residents, as fiscal resources allow.

Why is this important?

Eating healthy foods reduces the risk of health problems such as diabetes, heart disease, excess weight, and obesity. In addition, a healthy diet is associated with better academic performance²⁴. Despite these known benefits, as of 2003, only a quarter of the nation’s population followed the government recommended diet that calls for eating five servings of fruits and vegetables a day²⁵. There are many factors that impede healthy eating such as a lack of grocery stores in the neighborhood, lack of transportation to get to a place that sells affordable, healthy foods, the expense of healthy foods compared to unhealthy foods, and limited time or knowledge to prepare healthy foods. The preceding goals and policies are aimed at encouraging healthy eating habits and eliminating the barriers that make it difficult for people to eat healthily.

ACCESS TO HEALTH CARE

Goal HEJ-6: Convenient and accessible health services that meet the needs of the community.

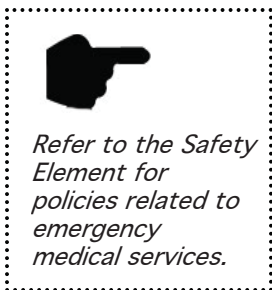

Policy HEJ-6.1: Encourage a range of health services in locations that are convenient and accessible (walkable) to the community.

Policy HEJ-6.2: Encourage local transit providers to establish and maintain routes and services that provide the

²⁴ Florence, M., Asbridge, M, and Veugelers, P. (2008). Diet quality and academic performance. *Journal of School Health*. Vol. 78(4): 209-215.

²⁵ Centers for Disease Control and Prevention (2006). Physical activity and good nutrition: Essential elements to prevent chronic diseases and obesity. Retrieved January 22, 2010 from <http://www.cdc.gov/nccdphp/publications/aag/pdf/dnpa.pdf>.



community with convenient access to health service facilities, where feasible.

Policy HEJ-6.3: Encourage businesses to provide and maintain a free shuttle service to health care facilities for residents, where feasible.

Why is this important?

When residents have easy and safe access to a variety of health care services, they have the opportunity to learn about good health care practices, prevent illness, and lessen the severity of illness.

LEAD BASED PAINT AND OTHER CONTAMINANTS IN THE HOME



Refer to the Housing Element for additional information regarding the City's efforts to remove lead based paint hazards.

Goal 7: The elimination of health risks associated with lead-based paint, mold, and other contaminants.

Policy 7.1: Inform the public about the risks associated with lead based paint, mold, and other contaminants and encourage and facilitate remediation.

Policy 7.2: Develop a process by which to identify residences with lead based paint hazards, notify residents of the potential hazard, and request landlords/owners to make the housing unit lead-safe.

Policy 7.3: Program the remediation of lead based paint in city structures, prioritizing efforts in buildings where children may be present.

Policy 7.4: Prioritize lead education and remediation programs to benefit low-income families.

Why is this important?

As indicated in the Existing Setting section, approximately 13,348 housing units were constructed prior to 1980 in National City and almost 600 of these units are at high risk for containing lead based paint hazards. Although the City has succeeded in mitigating 115 of these units as of 2008 through its Lead Hazard Control Program, there is still a long way to go to rid National City of its lead based paint hazards. Young children are at the highest risk of developing health problems as a result of lead exposure, and low income families often cannot afford to remove lead based paint hazards from their homes. Therefore, directing



resources towards low-income residences where young children reside is a priority. Educating residents about the steps they can take to reduce the risk of lead exposure also is an important step toward eliminating hazards.

ORDINANCE NO. 2013 – 2383

AN ORDINANCE OF THE CITY COUNCIL OF THE CITY OF NATIONAL CITY
AMENDING SECTIONS 18.30.360 AND 18.41.020 (C) OF TITLE 18
(LAND USE CODE) OF THE NATIONAL CITY MUNICIPAL CODE
RELATED TO FAST FOOD RESTAURANT LOCATIONAL REQUIREMENTS
AND DRIVE-THROUGH BUSINESS DESIGN GUIDELINES

WHEREAS, pursuant to the terms and provisions of the California Government Code, proceedings were duly initiated for the amendment of the National City Municipal Code; and

WHEREAS, pursuant to legal notice, hearings were held by the Planning Commission and the City Council of National City, and all persons interested were given the opportunity to appear and be heard before said Planning Commission and City Council; and

WHEREAS, the Planning Commission has regularly and duly certified its report to the City Council of National City and has recommended such amendment.

NOW, THEREFORE, the City Council does ordain as follows;

Section 1. All protests, if any, against said amendment to the Municipal Code and each of them be and hereby are denied and overruled.

Section 2. That Section 18.30.360 of Title 18 of the Municipal Code be amended to read as follows:

18.30.360 - Fast food eating places.

A. Additional Notice Required. In addition to notices required pursuant to Section 18.12.050, written notice for a public hearing on a conditional use permit for a fast food eating place shall be provided to occupants of property within a radius of three hundred feet of the exterior boundaries of the property where the fast food eating place will be located.

B. Fast food eating places shall be located a minimum of three hundred feet from any residential zoned properties, except for those located within the MXC 2 or MXD 2 zone.

Section 3. That Section 18.41.020 (C) of Title 18 of the Municipal Code be amended to read as follows:

18.41.020 - Nonresidential site planning standards. These standards apply to those areas in the city that will be developed as commercial use without a residential component (mixed-use) or areas where only a commercial use is permitted. This section considers two basic types of development: freestanding buildings and multi-tenant strip developments including mini-malls.

A. (No Change)

B. (No Change)

C. Drive-Through Businesses.

1. Minimum vehicular queuing distance shall be established through the conditional use permit process.

2. Drive through business aisles shall have a minimum interior turning radius of 25 feet for any curves. A smaller radius may be established through the conditional use permit process with the approval of the City Engineer.

3. A drive-through window or lane shall not be placed between the right-of-way or internal drive and the associated building unless a ten-foot wide landscape strip extending the entire length of the drive-through queuing is installed and maintained with a minimum three-foot height continuous hedge and ornamental trees spaced a minimum of twenty feet on center.

D. (No Change)

E. (No Change)

Section 3. The City Council has complied with the California Environmental Quality Act by separately adopting a Negative Declaration for this code amendment and finding there is no substantial evidence that the project will have a significant effect on the environment.

PASSED AND ADOPTED this 3rd day of September, 2013.

Ron Morrison, Mayor

ATTEST:

Michael R. Dalla, City Clerk

APPROVED AS TO FORM:

Claudia G. Silva
City Attorney

**CITY OF NATIONAL CITY, CALIFORNIA
COUNCIL AGENDA STATEMENT**

MEETING DATE: September 17, 2013

AGENDA ITEM NO. |

ITEM TITLE:

TEMPORARY USE PERMIT – St. Mary’s Fall Festival hosted by St. Mary’s Catholic Church on October 6, 2013 at the parish grounds located between E. 8th Street and “E” Avenue from 7 a.m. to 6:30 p.m. with no waiver of fees.

PREPARED BY: |Vianey Rivera|

DEPARTMENT: Neighborhood Services Division

PHONE: |(619) 336-4364|

APPROVED BY: _____

EXPLANATION:

This is a request from St. Mary’s Catholic Church to conduct the 2013 St. Mary’s Fall Festival event on Sunday, October 6, 2013 at their parish grounds on E. 8th Street & “E” Avenue. This event features approximately 20 assorted booths, including food booths, religious booths, white elephant booth, sewing club arts & crafts, and game booths. Two (2) 20x20 canopies will be set up for dining.

No street closures required for this event.

FINANCIAL STATEMENT:

APPROVED: _____ **Finance**

ACCOUNT NO. |

APPROVED: _____ **MIS**

|The City has incurred \$237.00 for processing the TUP through various City departments.

Total fees are \$237.00. |

ENVIRONMENTAL REVIEW:

|N/A|

ORDINANCE: INTRODUCTION: FINAL ADOPTION:

STAFF RECOMMENDATION:

|Approve the Application for a Temporary Use Permit subject to compliance with all conditions of approval with no waiver of fees. |

BOARD / COMMISSION RECOMMENDATION:

|N/A|

ATTACHMENTS:

|Application for a Temporary Use Permit with recommended approvals and conditions of approval.|

EVENT INFORMATION

Type of Event:

- Public Concert Fair Festival Community vent
 Parade Demonstration Circus Block Party
 Motion Picture Grand Opening Other _____

Event Title: ST. MARY'S FALL FESTIVAL

Event Location: PARISH PROPERTY CHURCH PARKING LOT 8TH & "E" STS.

Event Date(s): From SUNDAY, OCTOBER 6th 2013
to _____

Actual Event Hours: 7:00 am/pm to 6:30 am/pm

Total Anticipated Attendance: UNKNOWN (Participants Spectators)

Setup/assembly/construction Date: OCTOBER 4 / Start time: 8:00 a.m.

Please describe the scope of your setup/assembly work (specific details):

ON CHURCH GROUNDS, SET-UP INCLUDES ASSEMBLING BOOTHS
DECORATING BOOTHS, REPAIRING BOOTHS IF NEEDED

Dismantle Date: OCT. 7th Completion Time: 8:00 am/pm

List any street(s) requiring closure as a result of this event. Include street name(s), day and time of closing and day and time of reopening.

NO STREET CLOSURES

APPLICANT AND SPONSORING ORGANIZATION INFORMATION

Sponsoring Organization: ST. MARY'S CATHOLIC CHURCH

Chief Officer of Organization (Name) FATHER DENNIS MACALINTAL, PASTOR

Applicant (Name): ALICE & DON STEEBER CHAIRPERSONS

Address: 2929 EAST 16th STREET NATIONAL CITY

Daytime Phone: (619) 475-2424 Evening Phone: ()

Fax: () E-Mail: _____

Contact Person "on site" day of the event ALICE STEEBER Cellular: 619-507-9153

NOTE: THIS PERSON MUST BE IN ATTENDANCE FOR THE DURATION OF THE EVENT AND IMMEDIATELY AVAILABLE TO CITY OFFICIALS

FEES/PROCEEDS/REPORTING

Is your organization a "Tax Exempt, nonprofit" organization? YES NO

Are admission, entry, vendor or participant fees required? YES NO

If YES, please explain the purpose and provide amount(s):

\$ _____ Estimated Gross Receipts including ticket, product and sponsorship sales from this event.

\$ _____ Estimated Expenses for this event.

\$ _____ What is the projected amount of revenue that the Nonprofit Organization will receive as a result of this event?

**OVERALL EVENT DESCRIPTION
ROUTE MAP/SITE DIAGRAM/SANITATION**

Please provide a **DETAILED DESCRIPTION** of your event. Include details regarding any components of your event such as the use of vehicles, animals, rides or any other pertinent information about the event.

THIS IS AN ANNUAL PARISH EVENT, THERE WILL BE FOOD BOOTHS
RELIGIOUS BOOTHS, WHITE ELEPHANT BOOTH, SEWING CLUB ARTS AND CRAFTS,
GAME BOOTHS, BOYS & GIRLS SCOUTS BOOTHS, APPROXIMATELY 20
ASSORTED BOOTHS, THIS IS A ONE-DAY EVENT,

YES NO If the event involves the sale of cars, will the cars come exclusively from National City car dealers?

If NO, list any additional dealers involved in the sale:

OVERALL EVENT DESCRIPTION CONTINUED

YES NO Does the event involve the sale or use of alcoholic beverages?

YES NO Will items or services be sold at the event? If yes, please describe:

ITEMS: FOOD, SOFT DRINKS, ARTS/CRAFTS, PLANTS, RELIGIOUS ITEMS

YES NO Does the event involve a moving route of any kind along streets, sidewalks or highways? If YES, attach a detailed map of your proposed route indicate the direction of travel, and provide a written narrative to explain your route.

YES NO Does the event involve a fixed venue site? If YES, attach a detailed site map showing all streets impacted by the event.

YES NO Does the event involve the use of tents or canopies? If YES: Number of tent/canopies 10 Sizes 10x10 NOTE: A separate Fire Department permit is required for tents or canopies.

YES NO Will the event involve the use of the 2 20x20 Used for dining SPECIFY: City or your stage or PA system?

In addition to the route map required above, please attach a **diagram** showing the overall layout and set-up locations for the following items:

Alcoholic and Nonalcoholic Concession and/or Beer Garden areas.
 Food Concession and/or Food Preparation areas Please describe how food will be served at the event: FOOD PREPARED ON SITE IN SOMMERCIAL KITCHENS, SOLD IN
 If you intend to cook food in the event area please specify the method:
 GAS ELECTRIC CHARCOAL OTHER (Specify): FOOD BOOTHS

city

Portable and/or Permanent Toilet Facilities
 Number of portable toilets: 0 (1 for every 250 people is required, unless the applicant can show that there are facilities in the immediate area available to the public during the event)

- Tables # 10 and Chairs # 100
- Fencing, barriers and/or barricades
- Generator locations and/or source of electricity
- Canopies or tent locations (include tent/canopy dimensions)
- Booths, exhibits, displays or enclosures
- Scaffolding, bleachers, platforms, stages, grandstands or related structures
- Vehicles and/or trailers
- Other related event components not covered above
- Trash containers and dumpsters

(Note: You must properly dispose of waste and garbage throughout the term of your event and immediately upon conclusion of the event the area must be returned to a clean condition.) Number of trash cans: 15 Trash containers with lids: 15

Describe your plan for clean-up and removal of waste and garbage during and after the event:

TRASH CANS EMPTIED THROUGHOUT THE DAY AND EMPTIED INTO
TWO ON-SITE COMMERCIAL DUMPSTERS THAT WILL BE PICKED UP BY EDCO.

ENTERTAINMENT/ATTRACTIONS AND RELATED EVENT ACTIVITIES

YES NO Are there any musical entertainment features related to your event? If YES, please state the number of stages, number of bands and type of music. Number of Stages: 1 Number of Bands: _____

Type of Music: D.J. FOR BACKGROUND MUSIC FOR PLEASURE AND DANCE GROUP ACTS,

YES NO Will sound amplification be used? If YES, please indicate: Start time: 1:00 p.m. am/pm Finish Time 5:00 p.m. am/pm

YES NO Will sound checks be conducted prior to the event? If YES, please indicate: Start time: _____ am/pm Finish Time _____ am/pm

Please describe the sound equipment that will be used for your event:

YES NO Fireworks, rockets, or other pyrotechnics? If YES, please describe:

YES NO Any signs, banners, decorations, special lighting? If YES, please describe:

ON PARISH PROPERTY, SIGNS, BANNERS, BOOTH DECORATIONS

SAFETY/SECURITY/ACCESSIBILITY

Please describe your procedures for both Crowd Control and Internal Security:

~~RESIDENTS AND BUSINESSES ARE AWARE OF OUR ANNUAL ONE-DAY FESTIVAL SECURITY: NOTIFYING NCPD TO ALERT RESERVE OFFICERS AND IF AVAILABLE SENIOR VOLUNTEER PATROL, WE WILL PROVIDE ON-SITE SECURITY.~~

YES NO Have you hired any Professional Security organization to handle security arrangements for this event? If YES, please list:

Security Organization: _____

Security Organization Address: _____

Security Director (Name): _____ Phone: _____

YES NO Is this a night event? If YES, please state how the event and surrounding area will be illuminated to ensure safety of the participants and spectators:

Please indicate what arrangement you have made for providing First Aid Staffing and Equipment.
~~FIRST-AID KITS AVAILABLE, REST AND QUIET AREAS AVAILABLE, FRANK PARRA, FIRE DEPARTMENT WILL BE ON SITE AS A PARISHIONER~~

Please describe your Accessibility Plan for access at your event by individuals with disabilities:

~~CHURCH HAS DISABLED PARKING SPACES IN ALL CHURCH PARKING LOTS AND ON STREETS, FESTIVAL GROUNDS ARE BLACK-TOPPED AND VERY LEVEL.~~

PARKING PLAN/MITIGATION OF IMPACT

Please provide a detailed description of your PARKING plan:

~~CHURCH PARKING LOTS AND CITY STREETS~~

Please describe your plan for DISABLED PARKING:

~~USE OF DISABLED PARKING SPACES~~

Please describe your plans to notify all residents, businesses and churches impacted by the event: _____

NOTE: Neighborhood residents must be notified 72 hours in advance when events are scheduled in the City parks.

City of National City

PUBLIC PROPERTY USE HOLD HARMLESS AND INDEMNIFICATION AGREEMENT

Persons requesting use of City property, facilities or personnel are required to provide a minimum of \$1,000,000 combined single limit insurance for bodily injury and property damage which includes the City, its officials, agents and employees named as additional insured and to sign the Hold Harmless Agreement. Certificate of insurance must be attached to this permit.

Organization _____ ST. MARY'S CATHOLIC CHURCH _____

Person in Charge of Activity _____ FATHER DENNIS MACALINTAL _____

Address ALICE & DON STEEBER (CHAIRPERSONS) _____
PARISH OFFICE 426 EAST 8TH STREET

Telephone CHURCH OFFICE _____ **Date(s) of Use** SUNDAY OCTOBER 6, 2013
474-1501 _____
FESTIVAL IS ON CHURCH PROPERTY

HOLD HARMLESS AGREEMENT

As a condition of the issuance of a temporary use permit to conduct its activities on public or private property, the undersigned hereby agree(s) to defend, indemnify and hold harmless the City of National City and the Parking Authority and its officers, employees and agents from and against any and all claims, demands, costs, losses, liability or, for any personal injury, death or property damage, or both, or any litigation and other liability, including attorneys fees and the costs of litigation, arising out of or related to the use of public property or the activity taken under the permit by the permittee or its agents, employees or contractors.

Signature of Applicant Official Title Date

For Office Use Only

Certificate of Insurance Approved _____ Date _____

2013

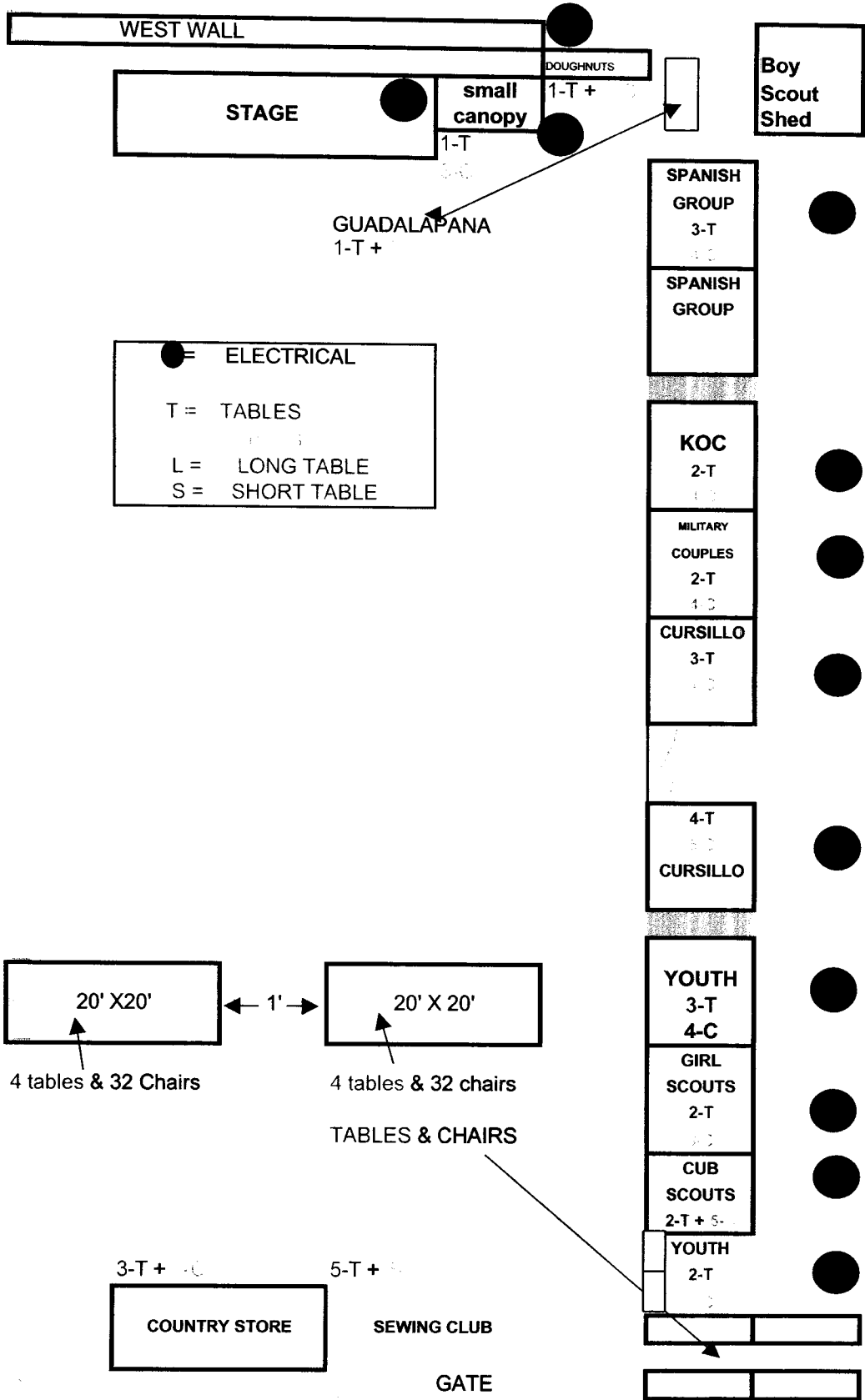
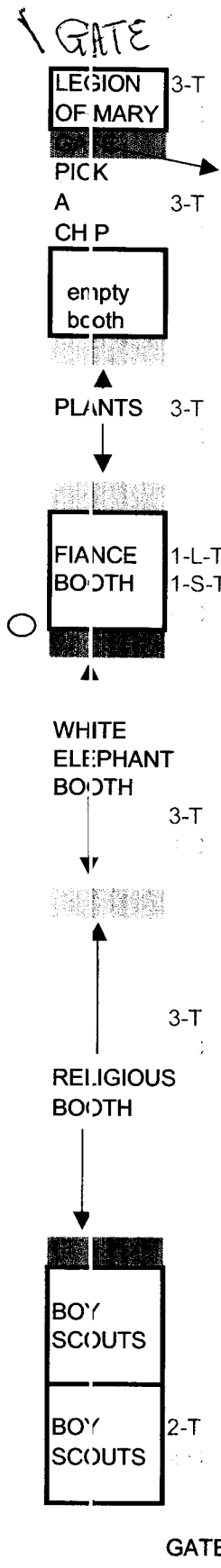

GATE

GATE

**CITY OF NATIONAL CITY
NEIGHBORHOOD SERVICES DIVISION
APPLICATION FOR A TEMPORARY USE PERMIT
RECOMMENDATIONS AND CONDITIONS**

SPONSORING ORGANIZATION: St. Mary's Catholic Church
 EVENT: St. Mary's Fall Festival
 DATE OF EVENT: **October 6, 2013**
 TIME OF EVENT: 7 a.m. to 6:30 p.m.

APPROVALS:

DEVELOPMENT SERVICES	YES [x]	NO []	SEE CONDITIONS [x]
RISK MANAGER	YES [x]	NO []	SEE CONDITIONS [x]
PUBLIC WORKS	YES [x]	NO []	SEE CONDITIONS [x]
FINANCE	YES [x]	NO []	SEE CONDITIONS [x]
FIRE	YES [x]	NO []	SEE CONDITIONS [x]
COMMUNITY SERVICES	YES [x]	NO []	SEE CONDITIONS [x]
POLICE	YES [x]	NO []	SEE CONDITIONS [x]
CITY ATTORNEY	YES [x]	NO []	SEE CONDITIONS [x]

CONDITIONS OF APPROVAL:

DEVELOPMENT SERVICES (619) 336-4318

Speakers shall face away from residential areas. Compliance with Title 12 required.

RISK MANAGER (619) 336-4370

Provide valid copy of insurance certificate naming the City of National City.

Provide Additional insured endorsement naming the City of National City as an additional named insured

PUBLIC WORKS (619)366-4580

Public Works has no involvement in this event

FINANCE

* Festivals, Craft shows, etc. *

A Business License is required IF monies are solicited, admission fee is charged, or if food, beverages and merchandise are sold. The organization holding this event and each vendor present at this event must have a separate business license. Vendors currently licensed by the City may operate under their existing license.

A list of all participating vendors (with their address, phone number, and current National City business license number) is to be provided to the Revenue & Recovery Division of the Finance Department two weeks prior to the event for verification of business licenses.

If any of the vendors or organizations is registered not-for-profit, there will be no charge for a business license. However, a business license certificate must be obtained from the City Revenue & Recovery Division, Business License Section. (Note: a clearance fee does apply to Non-profit organizations located in National City that submit an initial business license application.)

FIRE (619) 336-4550

NO COST FOR AFTER HOURS INSPECTION DUE TO DIRECTOR PARRA'S ATTENDANCE. DIRECTOR PARRA WILL CONDUCT AFTER HOURS INSPECTION WHILE AT EVENT

Stipulations required by the Fire Department for this event are as follows:

- 1) Access to the church to be maintained at all times, to both entrances and Fire Department connections for fire sprinkler systems, standpipes, etc
- 2) Fire Hydrants shall not be blocked or obstructed
- 3) Fire Department access into and through the festival areas are to be maintained at all times. Fire apparatus access roads shall have an unobstructed width of not less than 20 feet and an unobstructed vertical clearance of not less than 13 feet 6 inches
- 4) Participants on foot are to move immediately to the sidewalk upon approach of emergency vehicle(s)
- 5) Vehicles in roadway are to move immediately to the right upon approach of emergency vehicle(s)
- 7) All cooking booths or areas to have one 2A:10BC fire extinguisher. If grease or oil is used in cooking a **40:BC or class "K" fire extinguisher** will be required. Concession stands utilized for cooking shall have a minimum of 10 feet of clearance on two sides. **All fire extinguishers to have a current State Fire Marshal Tag attached. Please see attached example**
- 8) Fire extinguishers to be mounted in a visible location between 3½'to 5' from the floor to the top of the extinguisher. Maximum travel distance from an extinguisher shall not be more than 75 feet travel distance. ***Please see attached example***

- 9) If Charcoal is being used, provide metal cans with lids and label "HOT COALS ONLY" for used charcoal disposal
- 10) A fire safety inspection is to be conducted by the Fire Department prior to operations of the event to include all cooking areas etc.
- 11) Required inspections taking place, after hours, holidays, and weekends will be assessed a minimum of one hundred (\$200.00) dollars. **Fee is to be paid directly to the National City Fire Department Administration offices prior to event**
- 12) Any electrical power used is to be properly grounded and approved. Extension cords shall be used as "Temporary Wiring" only
- 13) If tents or canopies are used, tents having an area in excess of 200 square feet and or canopies in excess of 400 square feet or multiple tents and or canopies placed together equaling or greater than the above stated areas, are to be used, they shall be flame-retardant treated with an approved State Fire Marshal seal attached. A ten feet separation distance must be maintained between tents and canopies. A permit from the Fire Department must be obtained. ***Cooking shall not be permitted under tents or canopies unless the tents or canopies meet "State Fire Marshal approval for cooking. If cooking is to be done, a ten feet separation shall be maintained from cooking appliance and canopies.*** Certificate of State Fire Marshal flame resistancy shall be provided to the National City Fire Department if applicable. *If canopies maintain a ten feet separation distance from one another, no charge will be assessed*

Canopies:

0 – 400 sf -	\$0
401 – 500 sf -	\$250.00
501 – 600 sf -	\$300.00
601 – 700 sf -	\$400.00

Tents:

0 –200 sf -	\$200.00
201 – (+) sf -	\$400.00

NOTE: Booths can be grouped in multiples of 4 not to exceed 400 square feet. A separation of ten feet between multiples of 4 booths shall be required

- 14) First Aid will be provided by organization

Note: Fees can only be waived by City Council.

COMMUNITY SERVICES

No comments.

POLICE

The Police Department does not have any stipulations I will request reserves and put out "extra patrol" for the squads that are on duty

CITY ATTORNEY

Requires an indemnification and hold harmless agreement, and a policy of general liability insurance, with the City and its officials, employees, agents and volunteers as additional insureds, with amounts of coverage to be determined by the Risk Manager.

**CITY OF NATIONAL CITY, CALIFORNIA
COUNCIL AGENDA STATEMENT**

MEETING DATE: September 17, 2013

AGENDA ITEM NO. _____

ITEM TITLE:

Staff Update – Council approved 2013-2018 Strategic Plan

PREPARED BY: Leslie Deese, City Manager

DEPARTMENT: City Manager

PHONE: 619-336-4240 

APPROVED BY: _____

EXPLANATION:

Staff will provide the City Council with a verbal update on the 2013-2018 Strategic Plan.

FINANCIAL STATEMENT:

ACCOUNT NO. N/A

APPROVED: _____ Finance

APPROVED: _____ MIS

There is no fiscal impact associated with this item.

ENVIRONMENTAL REVIEW:

N/A

ORDINANCE: INTRODUCTION: FINAL ADOPTION:

STAFF RECOMMENDATION:

Receive and File

BOARD / COMMISSION RECOMMENDATION:

N/A

ATTACHMENTS:

2013-2018 Council approved Strategic Plan



2013-2018 Strategic Plan

APPROVED BY CITY COUNCIL ON JUNE 18, 2013

City of National City Strategic Plan

1. Provide Quality Services

- a) Practice the five core values (Commitment, Customer Service, Courtesy, Communication, and Collaboration) with our diverse customer base.
Leslie Deese
- b) Align workforce with City's objectives and provide training and support necessary to fully develop employees.
Stacey Stevenson
- c) Expand public access to City services and information, including Legislative platform consistent with City Council policy.
Mike Dalla Lauren Maxilom
- d) Pursue public safety goals and objectives and enhance disaster preparedness (Police, Fire, Emergency Medical Services, Homeland Security).
Manual Rodriguez Frank Parra
- e) Analyze internal processes for efficiency and implement technology solutions where feasible.
Stacey Stevenson Ron Williams

2. Achieve Fiscal Sustainability

- a) Prepare effective budget, accurately forecast funding sources, manage investments wisely, provide consistent financial reports, maintain clean audits, resolve findings/deficiencies in a timely manner, and update finance and budget policies.
Mark Roberts
- b) Prepare a 3 year operating plan that prioritizes service and staffing levels in preparation for sunset of district tax.
Stacey Stevenson
- c) Establish economic development programs to retain existing businesses and stimulate new investments.
Brad Raulston
- d) Fund replacement reserves, or create financing plans, for fleet, facilities and other City assets.
Brad Raulston Steve Manganiello
- e) Build cooperative partner with community organizations, schools, and other public agencies in the efficient and cost effective delivery of services.
Brad Raulston Jessica Cissel

3. Improve Quality of Life

- a) Implement Neighborhood Action Plans and continue amortization efforts by working with residents to prioritize projects.
Brad Raulston Armando Vergara
- b) Pursue green initiatives and build a sustainable city.
Steve Manganiello Brad Raulston
- c) Help organize community events and support social gatherings that benefit the total community.
Brad Raulston Jessica Cissel Lauren Maxilom
- d) Update sign ordinance to improve community character and draw attention to important gateways, corridors and intersections.
Claudia Silva Martin Reeder
- e) Support Pier 32 (GB Capital Holdings) expansion plans and work with San Diego Unified Port District and its tenants to fund public process and public improvements.
Brad Raulston Ray Pe

4. Enhance Housing and Community Assets

- a) Continue providing housing opportunities at all income levels and develop programs to improve existing conditions.
Alfredo Ybarra
- b) Relocate the public works yard to utilize the existing site for a neighborhood park and affordable family housing (Westside Infill Transit Oriented Development: WI-TOD or Paradise Creek Project).
Brad Raulston Carlos Aguirre
- c) Maintain and improve City's infrastructure and find alternative funding to construct public facilities, park improvements, and other capital needs.
Steve Manganiello Assistant Director (Maintenance) Barby Tipton (CIP)
- d) Preserve and promote historic resources and cultural assets.
Brad Raulston Martin Reeder
- e) Administer real property assets to achieve the City's long term goals.
Alfredo Ybarra Carlos Aguirre

5. Promote a Healthy Community

- a) Expand opportunities for walking and biking through the development of Community Corridors and Safe Routes to Schools consistent with the National City General Plan and Bicycle Master Plan.

Steve Manganiello

- b) Continue to provide affordable City programs, activities and services that are accessible for all users, including individuals with disabilities (Americans with Disabilities Act).

Steve Manginello

Brad Raulston

- c) Enhance neighborhood services programs such as graffiti abatement, parking enforcement, and code enforcement.

Brad Raulston

Armando Vergara

- d) Create an Environmental Compliance division that serves as a single point of contact for environmental issues and inform the public about new programs and policies.

Steve Manganiello

Barby Tipton

- e) Advance National City wellness programs for youth, families, seniors and City employees that encourage a healthy lifestyle.

Internal-

Walter Amedee

External-

Jessica Cissel

Frank Parra

Brad Raulston

**CITY OF NATIONAL CITY, CALIFORNIA
COUNCIL AGENDA STATEMENT**

MEETING DATE: September 17, 2013

AGENDA ITEM NO. _____

ITEM TITLE:

Staff Report: Working outline and timeline for the development of the City of National City Three Year Operating Plan

PREPARED BY: Stacey Stevenson

PHONE: 336-4308

EXPLANATION:

See attached staff report.

DEPARTMENT: Administrative Services

APPROVED BY: _____



FINANCIAL STATEMENT:

ACCOUNT NO. _____

There is no fiscal impact associated with this report

APPROVED: _____ Finance

APPROVED: _____ MIS

ENVIRONMENTAL REVIEW:

This is not a project and therefore is not subject to environmental review.

ORDINANCE: INTRODUCTION: FINAL ADOPTION:

STAFF RECOMMENDATION:

Accept the staff report

BOARD / COMMISSION RECOMMENDATION:

N/A

ATTACHMENTS:

Staff Report



City Council Staff Report

September 17, 2013

ITEM

Staff Report: Working outline and timeline for the development of the City of National City Three Year Operating Plan.

BACKGROUND

The City Council of the City of National City held budget and strategic planning workshops on April 9, April 30 and May 14, 2013. On June 19, 2013 the City Council adopted the City of National City fiscal year 2014 operating budget and a five year Strategic Plan. The Strategic Plan, as adopted, includes initiative 2b, “prepare a 3 year operating plan that prioritizes service and staffing levels in preparation for sunset of district tax”.

On June 6, 2006, National City voters passed a measure increasing the local sales tax by one percent (1%) for a period of up to ten years for the restoration of services to the community. The local, or district sales tax (also known as Proposition D) became effective on October 1, 2006, with an anticipated sunset date of September 30, 2016. As a provision of the measure, at the five year mark an independent committee of financial experts was appointed to study the City’s use of the district tax and make recommendations for the second five year period. The final committee report unanimously recommended that the district tax remain in place for the full ten years at the full one percent.

During the drafting of the Strategic Plan, it was noted that the sunset is anticipated to occur during the five year plan period; fiscal year 2017. While the independent committee analyzed the ten year window of the district taxes existence, initiative 2b is intended to assess the impact of the aftermath of its loss on services to the community and staffing. The purpose of this report is to provide the City Council with a brief update on the efforts underway to complete the Three Year Operating Plan.

DISCUSSION

At the direction of the City Manager, a work plan has been developed for completion of the Three Year Operating Plan. Actions taken to date include the following:

- The City Manager held tailgate meetings with employees in each City department to introduce the Plan and its purpose.
- A committee was established to provide oversight of this City-wide effort. The committee members are:
 - Stacey Stevenson, Director of Administrative Services
 - Brad Raulston, Executive Director
 - Manuel Rodriguez, Chief of Police
 - Frank Parra, Director of Emergency Services
 - Mark Roberts, Director of Finance
- One on one meetings were held with each department head to explain the exercise.
- Departmental instructions and worksheets were disseminated.

The district sales tax is a General Fund Revenue. In the current operating budget, the projected district tax revenue accounts for 24% of the City's General Fund Revenue. Using the current fiscal year as a base line, department heads have been provided with projected expenses (personnel, and maintenance and operation) for the next three fiscal years; fiscal years 2015, 2016 and 2017. With the district sales tax accounting for close to one quarter of the City's total General Fund Revenue, the loss of such funding is anticipated to have a significant negative impact on service levels and staffing. As such, the exercise calls for each department to evaluate the impact of a 24% reduction in General Fund revenue on its ability to meet expenditure projections. As drafted, the departmental plan worksheets call for an analysis of programs and services; a detailed description of necessary program changes, including reductions in service; and an identification of the impacts of such changes, including the impacts on the community, personnel and legal mandates.

Next steps in the process include:

- Completion of departmental plans on or before October 31, 2013
- A review of all submittals by the oversight committee with recommendations to the City Manager
- Development of a City-wide Plan based on the departmental plan exercise
- Presentation of a Three Year Operating Plan to the City Council at the second City Council meeting in January, 2014.

Project Timeline

Action	Date
Departmental Tailgates	July 31 – August 30
Department Head meetings	Week of August 26
Departmental Work Plan development	August 29 – October 31
Framework to City Council	September 17
Review of Work Plans	November 4 – November 22
Work Plan revisions / refinement	November 25 – December 9
Discussion with City Manager	w/o December 16
Presentation of Plan to City Council	January 21

FISCAL IMPACT

There is no fiscal impact associated with this staff report.

Attachments: Three Year Operating Plan Departmental Worksheet
Departmental Work Plan Instructions



Departmental THREE YEAR OPERATING PLAN

Department Name:

Department Description:

General Budget:

	2014 Adopted	2015 Estimated*	2016 Estimated*	2017 Estimated*
Revenues				
Expenditures				
Personnel				
M&O				
Total Expenditures				

*include all projected changes in expenditures, revenues and staffing (i.e. salary adjustments, staffing increases or reductions)

Program/Service

Description:

Objective:

Proposed Changes (describe changes including the effective date and any plans to phase in change or wind down a program if applicable)

Program Impacts

- Personnel
- Service delivery
 - Do other entities (public or private) perform the same or similar service?
- Legal mandate?
- Strategic element?
- Estimated Savings

[Bullet points are provided as examples of the type of information to be included. The bullets should not be included in the completed plan document.]

Revised General Fund Budget:

	2014 Adopted	2015 Estimated*	2016 Estimated*	2017 Estimated*
Revenues				
Expenditures				
Personnel				
M&O				
Total Expenditures				



THREE YEAR OPERATING PLAN WORKSHEET INSTRUCTIONS

Purpose:

The Three Year Operating Plan is intended to assist the City in identifying and planning for the impacts of significant changes in projected revenues and expenditures. The attached worksheet is provided to facilitate your completion of this exercise.

Objective:

Based on projections for the current fiscal year, the District Sales Tax (Proposition D) accounts for 24% of the City's General Fund revenue. As currently established by a voter approved ballot measure, said tax is scheduled to sunset in September, 2016. At the direction of the City Manager, all departments are asked to provide an operational outlook based on the loss of 24% of General Fund revenue.

Deadline:

Please return the completed worksheet by the close of business October 31, 2013.

Instructions:

1. General Fund Budget – To assist you in this exercise you have been provided with a budget table.
 - a. For each fiscal year, provide a projection of your General Fund revenue.
 - b. Your personnel costs have been projected for you. The current year (2014) is projected based on current staffing. Fiscal years 2015 – 2017 include projected increases in personnel related expenses (i.e health care and Workers' Compensation).
 - c. Your Maintenance and Operation expenses have been held at the fy 2014 level.
 - d. If you are an Internal Service Fund, your worksheet will show a revenue figure reflecting the amount that you receive from the General Fund in lieu of General Fund expenditures.

If you are aware of any projections that will significantly impact your revenues or expenses in fiscal years 2015, 16 and/or 17, (i.e loss of a grant, addition of additional

staff, increased costs resulting from legislative mandates, receipt of a new funding stream) please adjust the numbers accordingly, making sure you carry over any adjustments to future years as appropriate.

2. Program/Service – Describe the program or service that is being impacted by the adjustment.
3. Proposed Changes – Describe what would change i.e a 10% reduction in supplies and materials budget; reallocating 3% of personnel costs to a non-general fund revenue stream; program operating hours reduced from 5 days a week to 3. In all cases, be specific in describing the change.

Indicate when the change would take effect. The District Tax will expire in September, 2016 (fy 2017). For example, will you begin to effect the change in fy 2016, at the beginning of fy 2017 (July 1, 2016), or mid-year 2017 (January, 2017)?

Do not propose a reduction in your Internal Service Charges. The Internal Service Funds are being asked to make adjustments.

4. Program Impacts – Describe in as much detail as you can the impact of the change i.e. the reduction in staffing will result in a \$10,000 loss in fee based revenue on an annual basis; the reduction will increase response times from 3 working days to 6 working days; the department will cease to perform the service; the change will result in the loss of 2 staff positions; the county will assume responsibility for providing the service. In all cases, be specific in describing the impact.

A spreadsheet listing all of your general fund positions, along with the base salary and loaded rate for each is provided to assist you. If you are proposing a reduction in staff, please remember that you are reducing positions, not people. Names of employees are provided to you so that you can see your current costs of operating your various programs. If the changes have to be effectuated in the future, the Human Resources Department would determine which employees are actually impacted based on established rules.

NOTE: if you are making adjustments in two or more program or service areas, please repeat steps 3 and 4 for each one. Do not lump them together.

5. Revised General Fund Budget – Once you have completed the exercise, recalculate your revenue and expenditure numbers and complete the provided chart based on your proposed adjustments.

Please return the completed worksheet to Stacey Stevenson by the close of business October 31, 2013.

Discussion on the Formation of a Military Advisory Committee

The City of National City has seven (7) established Boards and Commissions whose members are appointed by the Mayor and City Council. The City also has a number of ad-hoc committees which are generally short-term in nature and for a specific purpose, and are generally comprised of city staff, community members, and City Councilmembers.

At the September 3, 2013 City Council meeting, I requested the City Council consider forming a military advisory committee to provide a collaborative forum on military issues that may be addressed locally, to recognize residents who are veterans and active duty military, assist with special events to honor the military, and ensure adherence to military protocol such as the flying of flags, etc.

The City Council requested the item be brought back on a subsequent agenda to discuss parameters of the committee, including its purpose, responsibility, membership, meeting time and location, and duration of existence.

Background:

The City of National City shares a unique relationship with the U.S. Military, stretching back decades. This is due, in large part, to housing a major portion of Naval Base San Diego along the City's waterfront. We take pride in honoring National City's fallen service members and hometown heroes. These heroes will forever be remembered not only for their service to our County, but for their roles in families and their community.

Some of the events the City participates in to recognize and honor our veterans and military personnel include:

- Fallen heroes are remembered at the Kimball Bowl War Memorial, which is fully dressed on major holidays.
- The City's "Armed Services Recognition Program" honors hometown heroes, past and present (link provided): (<http://www.nationalcityca.gov/index.aspx?page=529>)
- The National City Chamber of Commerce hosts annual events to honor our Navy, which includes the City-sponsored Salute to Navy Luncheon and Salute to Navy Shipboard Reception.
- La Vista Memorial Park honors the men and women who died while serving in the United States Armed Forces at its annual Memorial Day event.
- The City City is honored to employ several employees who are in the military reserves. The Military and Veterans Code requires that we provide full compensation to an employee for the first 30 days of active duty assignment, if the person has been in our employee for a period of

not less than one year. Under the City's military policy, to help alleviate a financial hardship, for 6 months following that initial 30 days, we supplement the military pay if it is less than the employee's City wages.

In addition, National City is home to several veterans and military organizations, most notably the Thomas H. Crosby, Jr. VFW, the American Legion Larry E. Bennett Post 255, as well as the National City Chamber's long-standing "Salute to Navy" event committee.

Several years ago, the City established an informal military advisory committee in partnership with our local VFW, American Legion, and other organizations to honor and recognize our veterans and military personnel. The committee was subsequently disbanded due to staffing and budgetary constraints.

This information is provided to assist my colleagues in their discussion of the item.