

CITY OF NATIONAL CITY
Downtown Specific Plan
 Draft September 2017



ACKNOWLEDGMENTS

City Council

Ron Morrison, Mayor
Albert Mendivil, Vice Mayor
Jerry Cano, Councilmember
Mona Rios, Councilmember
Alejandra Sotelo-Solis, Councilmember

Planning Commission

Roberto Garcia, Chairman
Ditas Yamane, Vice Chairman
George Baca, Commissioner
Maria De La Paz, Commissioner
Dolores Flores, Commissioner
Williams Sendt, Commissioner
Gonzalo Quintero, Commissioner

Executive Team

Leslie Deese, City Manager
Brad Raulston, Deputy City Manager
Stacey Stevenson, Deputy City Manager
Stephen Manganiello, Director of Public Works/City Engineer
Armando Vergara, Neighborhood Services Director
Alfredo Ybarra, Director Housing and Economic Development

Planning Division

Martin Reeder, Principal Planner
Raymond Pe, Principal Planner
Michael Fellows, Assistant Planner

Consultant Team

KTUA, Planning and Landscape Architecture
Dixon Resources Unlimited, Parking Management and Operations
DeBartolo + Rimanic Design Studio, Architecture
Michael Baker International, Urban Design and Environmental Planning



TABLE OF CONTENTS

1	INTRODUCTION	1
1.1	Preface	2
1.2	Purpose.....	2
1.3	Authority to Prepare.....	6
1.4	Organization of the Specific Plan	6
2	DOWNTOWN PROFILE AND CHARACTERISTICS	7
2.1	Context.....	8
2.2	Downtown Profile	10
2.3	Description of the Planning Area	12
2.4	Demographic Profile.....	12
2.5	Economic Considerations for the Specific Plan	15
3	LAND USE, ZONING, AND DEVELOPMENT STANDARDS	19
3.1	Introduction.....	20
3.2	Housing	20
3.3	Transfer of Development Rights	20
3.4	General Plan Goals and Policies Affecting the Specific Plan.....	21
3.5	Development Zones.....	22
4	CIRCULATION	43
4.1	Introduction.....	44
4.2	Existing Conditions	46
4.3	State and Federal Enabling Legislation and Directives	61
4.4	General Plan Goals and Policies Affecting the Specific Plan.....	63
4.5	Future Transportation Improvements.....	69



TABLE OF CONTENTS (CONT.)

5	PARKING	83
	5.1 Parking in Downtown National City	84
	5.2 Existing Conditions	86
	5.3 Recommendations	106
6	DEVELOPMENT REVIEW PROCESS	139
	6.1 Application	140
	6.2 Project Development Findings	140
	6.3 Land Use Regulations and Development Standards.....	141
	6.4 Criteria for Exemption from the Development Standards.....	141
	6.5 Levels of Review.....	141
	6.6 Environmental Review	145
	6.7 Consistency Report.....	145
	6.8 Notice of Public Hearing.....	146
	6.9 City Council Action	146
7	URBAN DESIGN GUIDELINES	147
	7.1 Urban Design Guidelines.....	148
	7.2 Urban Design Framework.....	148
	7.3 Urban Design Goals.....	148
	7.4 Downtown Design Districts.....	150
	7.5 Building Design Guidance	160
	7.6 Private Realm Design Guidance.....	162
	7.7 Public Realm Design Guidance.....	187
8	FUTURE IMPLEMENTATION PROGRAMS	233
	8.1 Implementation Strategy	234
9	APPENDICES	237
	9.1 Glossary.....	238
	9.2 National City Downtown Parking Action Plan	243



LIST OF FIGURES

Figure 1-1: Specific Plan (DSP) Boundary.....	3
Figure 2-1: National City Regional Context.....	9
Figure 2-2: Downtown National City Destinations	11
Figure 2-3: Downtown National City Specific Plan Area	13
Figure 3-1: Development Zones	24
Figure 3-2: Height Restrictions	25
Figure 3-3: Height Restrictions 3D Model	26
Figure 4-1: Existing Roadway Classification	47
Figure 4-2: Existing and Proposed Community Corridors	48
Figure 4-3: Main Street - 8th Street	49
Figure 4-4: Main Street National City Boulevard.....	50
Figure 4-5: Multi-Modal Corridor	51
Figure 4-6: Urban Trail/Green Street.....	52
Figure 4-7: Existing Transit Routes and Stops.....	58
Figure 4-8: Existing and Proposed Urban Trails.....	59
Figure 4-9: Existing and Proposed Bicycle Facilities.....	60
Figure 4-10: Circulation Improvements.....	70
Figure 4-11: Proposed Roadway Improvements.....	73
Figure 4-12: Potential Roadway Improvements on 8th Street.....	74
Figure 4-13: Potential Roadway Improvements on Roosevelt Avenue	74
Figure 4-14: Option A - Parallel Parking and Multi-Use Path.....	78
Figure 4-15: Option B - Angled Parking.....	78
Figure 4-16: Proposed NEV Shuttle Routes	81
Figure 5-1: Existing Residential Permit Parking Zones.....	94
Figure 5-2: Privately-Operated Off-Street Parking Lots.....	97
Figure 5-3: On-street Parking Inventory Map.....	100
Figure 5-4: Potential On-Street Angled Parking Survey	101
Figure 5-5: On-Street Parking Occupancy Survey	103
Figure 5-6: Example of Inconsistent Signage	110
Figure 5-7: Example of Inadequate Signage.....	111
Figure 5-8: Inadequate Curb Marking Example	111
Figure 5-9: Phase 1 Implementation Plan	113



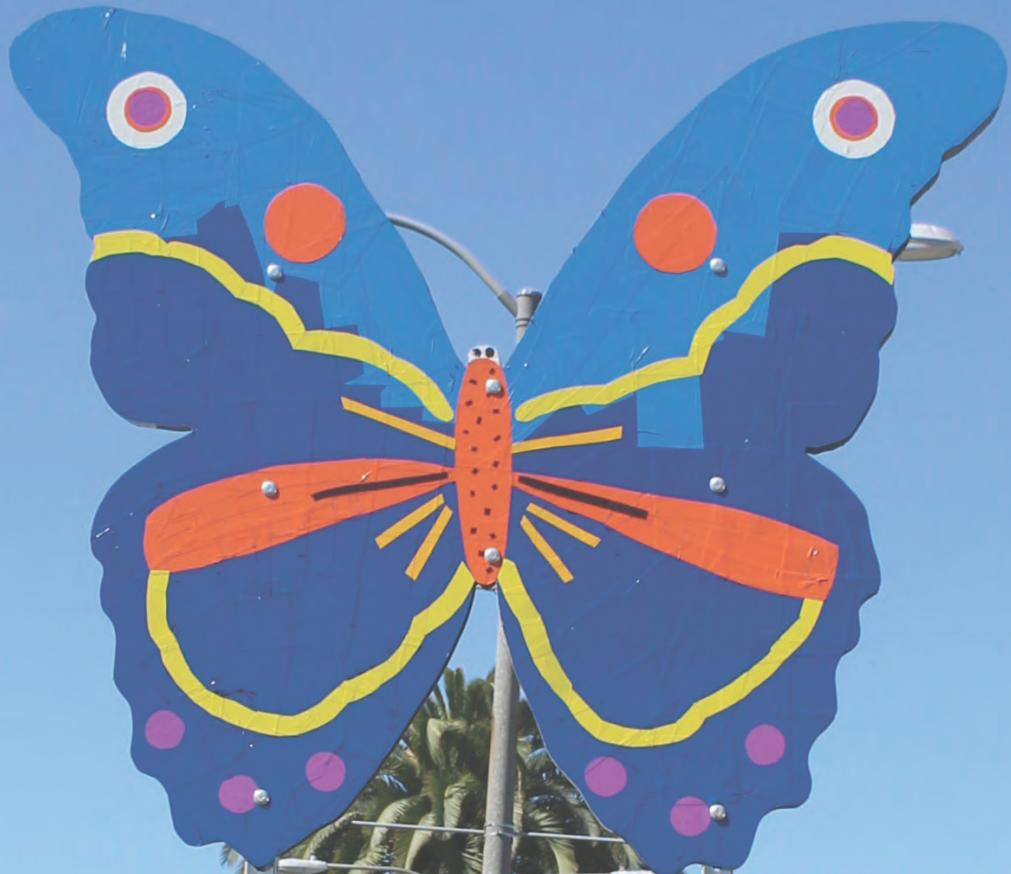

LIST OF FIGURES (CONT.)

Figure 5-10: On-Street Angled Parking Conversion Plan	116
Figure 5-11: Oversized Vehicle Parking Prohibitions	121
Figure 5-12: Roosevelt Avenue Angled Parking Option	122
Figure 5-13: Roosevelt Avenue Parallel Parking and Multi-Use Path.....	122
Figure 5-14: Expansion of Residential Permit Parking	126
Figure 5-15: Single Space Parking Meters and Time Restricted Parking.....	129
Figure 5-16: Phase 2 Implementation Plan.....	131
Figure 5-17: Phase 3 Implementation Plan	136
Figure 6-1: Planning Process Flow Chart	142
Figure 6-2: Project Levels and Review Process.....	143
Figure 7-1: Downtown Design Districts.....	151
Figure 7-2: "Main Street Type" Retail District Map	152
Figure 7-3: Sample Block for "Main Street Type" Retail District.....	153
Figure 7-4: Visitor/Education Village District Map.....	154
Figure 7-5: Sample Block for Visitor/Education Village District.....	155
Figure 7-6: General Commercial Emphasis Map	156
Figure 7-7: Sample Block for General Commercial District	157
Figure 7-8: Neighborhood Transition Emphasis Map	158
Figure 7-9: Sample Block for Neighborhood Transition District.....	159
Figure 7-10: Public Realm Categories	187
Figure 7-11: Street Typologies.....	189
Figure 7-12: Typical Walkway Zones	197
Figure 7-13: Streetscape Design Segments.....	214
Figure 7-14: Downtown Signage Plan	219
Figure 7-15: Public Art Plan.....	223
Figure 7-16: Streetscape Design Treatments	228
Figure 7-17: Street Tree Photos.....	230



LIST OF TABLES

Table 2-1: Planning Area Demographics.....	16
Table 2-2: Current Household Expenditures for Households	17
Table 2-3: Downtown National City Expenditure Potential.....	17
Table 3-1: Land Use Regulations and Development Standards	23
Table 4-1: National City Commuter Modal Split.....	45
Table 5-1: Plan Implementation	85
Table 5-2: Off-Street Parking Requirements for Downtown Development	89
Table 5-3: Key Citywide Off-Street Parking Requirements	90
Table 5-4: Privately-Operated Off-Street Parking Lots.....	98
Table 5-5: On-Street Parking Supply in the Four Priority Study Areas.....	99
Table 5-6: On-Street Parking Average Weekday Occupancy Rates	104
Table 5-7: Summary of Recommendations & Suggested Implementation Phasing.....	107
Table 5-8: Comparative Analysis of Parking Violation Fee Amounts.....	118
Table 5-9: Roosevelt Existing Conditions	123
Table 5-10: Parallel Parking (Both Sides) and Multi-Use Path.....	123
Table 5-11: West Side Angled Parking and East Side Parallel Parking.....	123
Table 5-12: Parking Transportation Demand Management Worksheet	127
Table 7-1: Walkway Width per District.....	197
Table 7-2: Recommended Street Improvements	215
Table 7-3: Recommended Street Trees.....	229

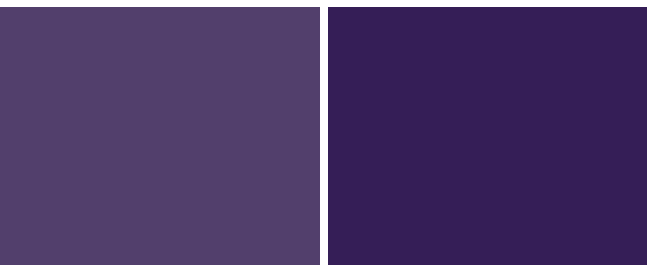
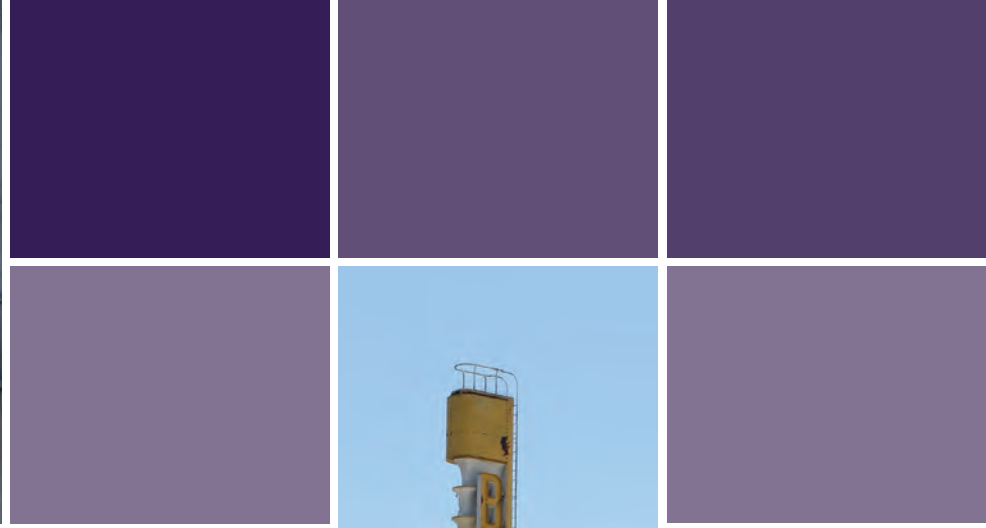

1

INTRODUCTION

1.1 PREFACE

The National City Downtown Specific Plan (Specific Plan) provides the framework for future development and public improvements for a 158-acre district for downtown National City (see Figure 1-1). The Specific Plan has been developed in accordance with the California Environmental Quality Act (CEQA), California planning law, The City of National City (City) planning policies, and input from community members, landowners, decision-makers, and City staff. The Specific Plan provides a comprehensive land use, parking, and circulation plan along with design guidelines that support the Specific Plan's goals and policies and guides future public and private development. In addition, the Specific Plan includes a strategy for its implementation and mechanisms to ensure that development will be coordinated and will meet the intent of the Specific Plan. The Specific Plan is financed through a Smart Growth Incentive Grant from the San Diego Association of Governments (SANDAG) through Transnet Funds. The intent of the grant is to provide financial support to cities to plan for smart growth planning and smart parking policies, encourage appropriate development, support affordable housing, and encourage transit supportive development that allows people to live with less dependence on single-occupied vehicles.

1.2 PURPOSE

The Specific Plan's purpose is to provide a guiding policy document to support smart growth and the revitalization of downtown. This is accomplished through encouraging and facilitating appropriate development, enhancing the public realm, improving mobility, effectively managing parking, providing a more streamlined development process, and continuing to preserve historic and character defining buildings.

The Specific Plan is consistent with the City's General Plan and Climate Action Plan, recognizes the changes in retail viability and shopping patterns, adapts to parking and mobility trends, adjusts to changing demographics, and increases the user-friendliness of the document.



Brick Row



Bay Theatre



Street improvements on 8th Street



The Ramada Hotel, the tallest building in downtown

Figure 1-1: Specific Plan (DSP) Boundary

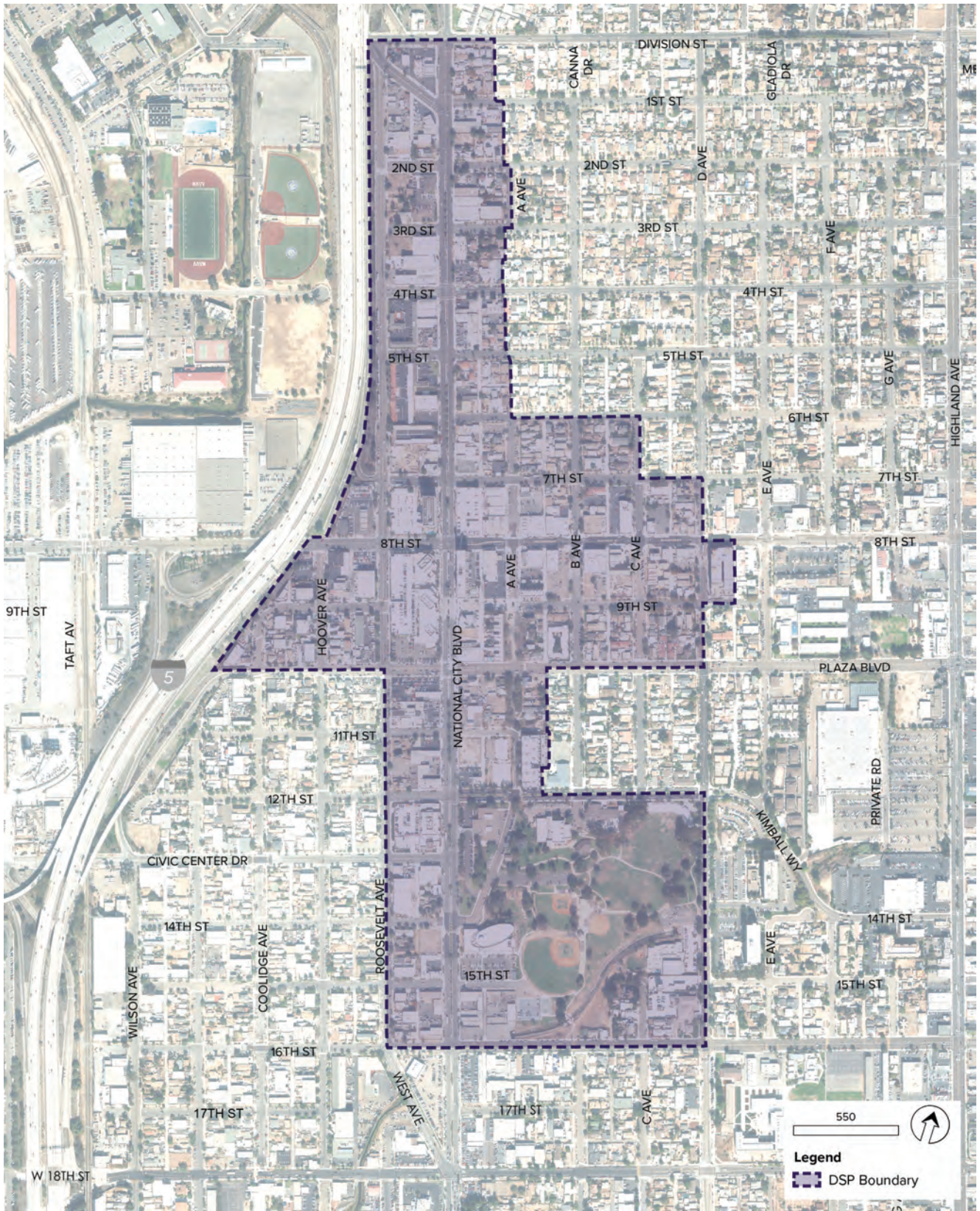

1.2.1 SPECIFIC PLAN'S GOALS AND OBJECTIVES

1.2.1.1 GOAL: *Significant Economic Investment and Revitalization in Downtown*

Objectives:

- A.** A substantial increase of Navy personnel that live and shop in down- town.
- B.** Housing densities that support local retail and service markets.
- C.** Adequate affordable housing that increases housing ownership levels.
- D.** Substantial local landowner and tenant involvement in development and real estate investments.
- E.** An appropriate mixture of retail and service uses that support the local economy.

1.2.1.2 GOAL: *Provide Housing.*

Objectives:

- A.** The preservation of housing and Naturally Occurring Affordable Housing (NOAH).
- B.** Reduce parking requirements. The Specific Plan establishes a parking bonus system for off-street parking/shared parking that reduces parking requirements or awards unit bonuses to developers that work to reduce VMT and promote TDM.
- C.** Provide a more streamlined review process: It is recommended to allow residential and/or commercial projects that are in conformance with the Municipal Code to be approved through a ministerial process. This is to encourage urban infill projects by shortening the process and allowing some surety in the development review.
- D.** Encourage smaller units by restructuring Developer Impact Fees (DIFs). Recalculate DIFs based on square footage of the unit, not based on the number of units. Changing to square footage provides a greater incentive

to build fewer larger units therefore increasing the supply of smaller units.

1.2.1.3 GOAL: *Effective Parking Management*

Objectives:

- A.** Increased numbers of small units with reduced parking needs.
- B.** The protection of adjacent neighborhoods from parking impacts.
- C.** Substantial reduction in parking demand and spill-over parking.
- D.** Appropriate amenities for parking facilities.
- E.** Efficient use of on-street parking.
- F.** Increased use of alternative transportation vehicles including motorcycles, scooters, bicycles, electric and other low emission vehicles, and small automobiles.
- G.** Increased use of carsharing, ridesharing, van-pooling, autonomous vehicles, and valet services.
- H.** Accessible and convenient public parking.
- I.** Efficient use of parking facilities and adequate turnover rates that support the land uses served

1.2.1.4 GOAL: *Desirable Land Use and Quality Urban Design*

Objectives:

- A.** Concentrated density closer to freeway on- ramps, lower volume roadways, and the trolley station.
- B.** Street level activation through land use regulations, development standards, and design guidelines.
- C.** The creation of micro-units with appropriate amenities.

- D.** High quality, intense, and dense development through land use regulations, development standards, and design guidelines.
- E.** The protection of public facilities, open space, and historic assets through land use regulations, development standards, and design guidelines.
- F.** Excellence in design of gateways, nodes, and district treatments.
- G.** An effective wayfinding system integrated with public amenities.
- H.** Adaptive reuse of buildings that have a main street character through the transfer of development rights (TDR) to accommodate adaptive reuse.
- I.** Increased connections to Paradise Creek and integration of other open space systems with parks and public realm spaces.
- J.** Appropriate buffering between single family neighborhoods in/or adjacent to the Planning Area and higher density development.

1.2.1.5 GOAL: User-Friendly Entitlement Process

Objectives:

- A.** A clear, well-defined, and streamlined project entitlement process.

1.2.1.6 GOAL: Avoidance or Mitigation of Impacts

Objectives:

- A.** No increase in impacts as analyzed in the Environmental Impact Report (EIR) certified in 2012, as amended.
- B.** No net increase in the number of vehicle trips as analyzed in the Environmental Impact Report (EIR) certified in 2012, as amended.
- C.** Avoidance of excessive gentrification and displacement of residents and tenants.

1.2.1.7 GOAL: Improved Mobility and Access

Objectives:

- A.** Clustering of dense projects at appropriate locations for access to transit, amenities, and services.
- B.** Extensive biking and walking facilities, as well as mixed land uses that lower vehicular trips and miles traveled.
- C.** Conformance with Green House Gas (GHG) emissions standards and Vehicle Miles Traveled (VMT) goals and statewide standards.
- D.** Improved and safe access to freeway on-ramps and off-ramps.
- E.** Shuttles and walking streets that connect downtown with Naval Base San Diego, transit, and development.
- F.** Expansion of multi-modal streets that include traffic calming, parking, bike, and pedestrian facilities.
- G.** Improvement of intersections for safe and efficient pedestrian and vehicular mobility.



A well designed infill project can help bring life back to streets by way of the design of the interface, the ground floor uses, and by adding more residents and potential customers to the local area

1.3 AUTHORITY TO PREPARE

National City has determined that a specific plan is the appropriate planning mechanism to guide long-range development of its downtown. A specific plan is a planning and regulatory tool made available to local governments by the State of California. By law, specific plans are intended to implement a city or county's general plan through the development of policies, programs, and regulations that provide an intermediate level of detail between the general plan and individual development projects. As vehicles for the implementation of the goals and policies of a city's general plan, State law stipulates that specific plans can be adopted or amended only if they are consistent with the jurisdiction's adopted general plan.

The Specific Plan is enacted pursuant to Sections 65450 through 65457 of the California Government Code, which authorizes local governments with certified general plans to prepare and adopt specific plans. The Specific Plan is adopted by the City Council by ordinance and thereby establishes the zoning regulations for land use and development within the Planning Area.

1.3.1 RELATIONSHIP TO GENERAL PLAN

The Specific Plan together with the City's General Plan, provides a framework that will guide future land use and development in the downtown. This Specific Plan is consistent with and serves as an extension of the National City General Plan, which will provide both policy and regulatory direction. When future development proposals are brought before the City, staff and decision-makers will use the Specific Plan as a guide for project review. Projects will be evaluated for consistency with the intent of Specific Plan policies and for conformance with development standards and design guidelines. For projects within downtown, the Specific Plan's policies and standards will take precedence over more general policies and standards that are applicable to the rest of the city. In situations where policies or standards relating to a particular subject have not been provided in the Specific Plan, the existing policies and standards of the City's General Plan and Land Use Code will continue to apply.

1.3.2 ENVIRONMENTAL REVIEW

The Specific Plan is in conformance with the certified Environmental Impact Report (EIR) for the 2012 Comprehensive Land Use Update, which included the General Plan, Land Use Code (Zoning), and the Specific Plan.

1.4 ORGANIZATION OF THE SPECIFIC PLAN

The Specific Plan is organized by the following chapters:

1. Introduction – Describes the goals and objectives of the Specific Plan, the authority to prepare, the relationship to the General Plan, and the environmental review.
2. Downtown Profile and Characteristics – Explains the context of the Planning Area to National City and greater San Diego and describes the Planning Area and the existing conditions.
3. Land Use/Zoning and Development Standards – Articulates the goals of the land use plan and describes the land use designations for the Planning Area.
4. Circulation – Explains the guidelines for a safe and efficient multi-modal transportation system for the future development of the Planning Area.
5. Parking – Plans for future growth and associated parking demand through policy and capital project recommendations.
6. Development Review Process - Describes the entitlement/approval process for development projects.
7. Design Guidelines – Explains the guidelines for the various design districts for private and public development.
8. Future Implementation Programs – Articulates the key actions for implementing the Specific Plan.
9. Appendices
 - 9.1 Glossary
 - 9.2 Parking Action Plan
 - 9.3 Findings to the Master EIR Memorandum
 - 9.4 Traffic Memorandum



2

DOWNTOWN PROFILE AND CHARACTERISTICS

2.1 CONTEXT

National City is 9.2 square miles (7.3 square miles land area) and was incorporated in 1887, the second oldest city in San Diego County. The population is approximately 59,869. The population is expected to grow to 85,121 in 2050 which is a 30 percent increase. The city is located 5 miles south of downtown San Diego and 10 miles north of Baja California, Mexico. National City is bordered by San Diego to the north and east, Chula Vista to the south, the unincorporated areas of Lincoln Acres and Bonita to the south and southeast, and San Diego Bay to the west (Figure 2-1).

The city has better than average automobile and public-transit access. Interstate 5 and Interstate 805 cross the city from north to south and

State Route 54 traverses the southern edge of the city. Bus service is available throughout the city via the Metropolitan Transit System (MTS) and light rail service is provided by two San Diego Trolley stations (Figure 2-1).

National City is mostly developed with a mix of residential neighborhoods and industrial and commercial uses. Important to the region's economy are the facilities of the Unified Port District, adjacent industrial developments, and Naval Base San Diego. The "Mile of Cars" provides a specialized, regional use with easy access from Interstate 5 and the South Bay Freeway (Route 54). At the other end of the city is Plaza Bonita, the largest retail center in the South Bay.



Figure 2-1: National City Regional Context

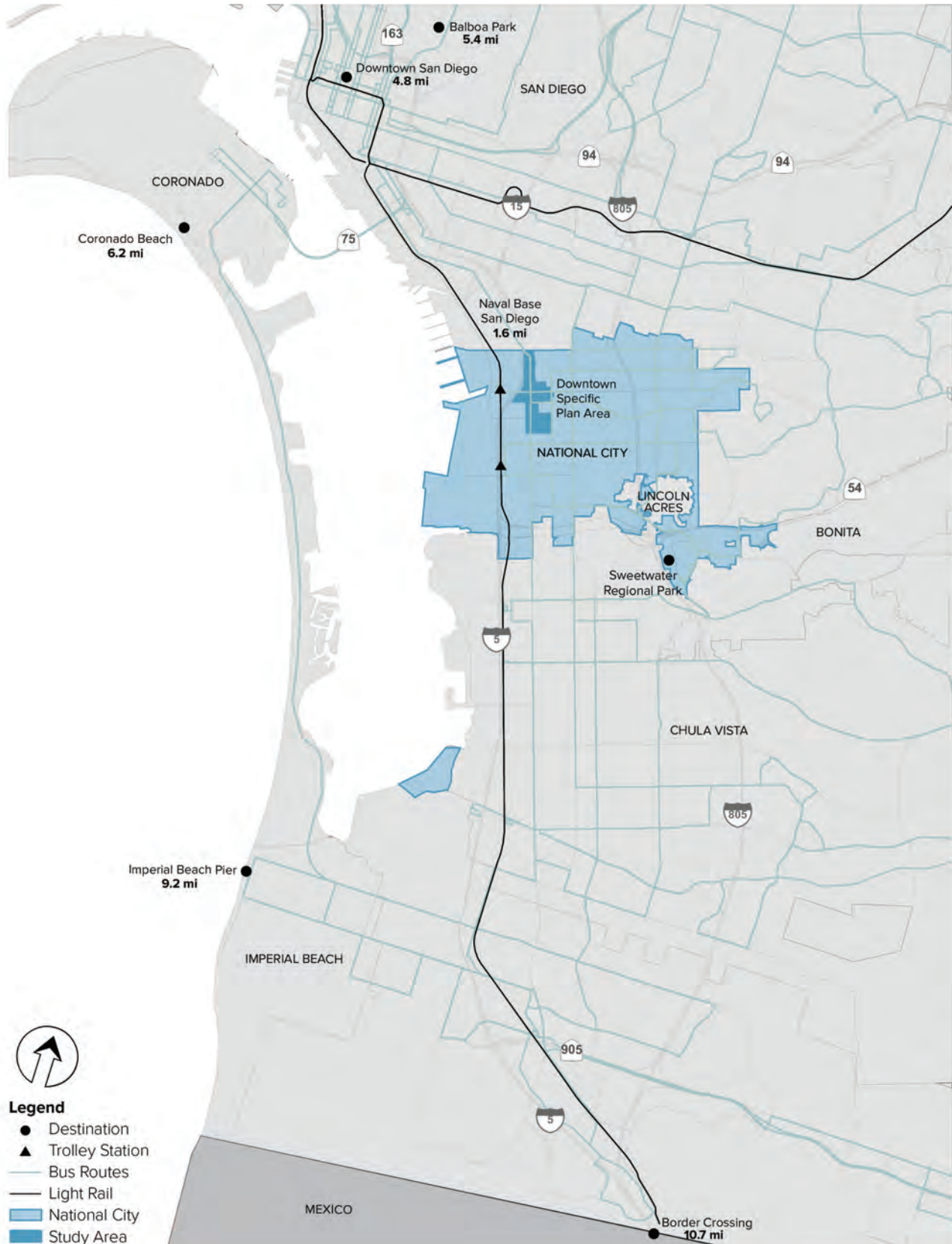

2.2 DOWNTOWN PROFILE

Downtown National City is a compact and intense district featuring several significant qualities (Figure 2-2). With City Hall, the library, social agencies, and numerous churches, downtown is the civic and cultural center. It is also superbly located in the heart of town, by remarkable freeway and surface street access, literally minutes away from anywhere in the city, and close to many regional assets such as the San Diego International Airport to the north and Mexico to the south. The downtown features a pedestrian-friendly, efficient street network of short blocks, human scale buildings, and relatively narrow streets. The downtown is visible from the elevated roadway of Interstate 5, which presents the opportunity to advance the image on National City with renovated buildings, lush landscaping, and a positive “curb appeal.”

Downtown contains an attractive collection of charming and rare historic buildings. In an era when people seek authentic and genuine experiences, the historic properties in downtown National City are exceptionally valuable assets that should be underpinned and promoted as a stimulus to investment. The historic properties are made all the more enticing because the downtown is flanked on three sides by charming, low-rise residential neighborhoods. These boroughs, with their assortment of Victorian cottages and homes, lend themselves to the creation of a distinct and rich walking environment linked to the downtown core.

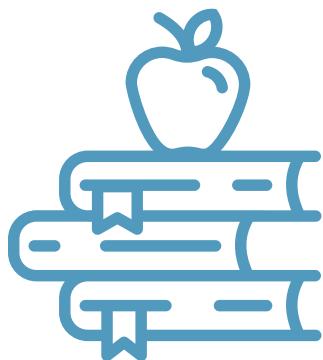

Up to **5,000** adults receive education in downtown National City

The core is a prime location for retail and multiple-family residential development. It also has an emerging skyline with two high-rise buildings that anchor it on the horizon and reinforce the district as a “central place.” Of particular note is the proximity of the downtown to Kimball Park, an emerald jewel that serves as a visual respite and a community gathering place.

It is difficult to overstate the significance of Education Village. This intense and architecturally engaging college campus occupies a place of prominence at the corner of 8th Street and National City Boulevard, an introductory gateway into the downtown from the Interstate 5 exit and the trolley station. Education Village, a joint venture of San Diego State University, Southwestern Community College, and the City of National City, provides a multi-year and adult education venue for over 5,000 students in downtown National City. Education Village includes attributes that directly benefit the level of activity throughout the downtown. The student and faculty population provides customers for local shops, and the sidewalk activity they engender helps elevate the activity level within the core. The campus includes a public plaza at the terminus of 9th street that endows National City with its own central metropolitan square - a place to meet and relax. Education Village adds a significant element to the downtown because it is a unique use not available elsewhere in the city. A college campus such as this helps enhance the image of downtown by transforming how it functions on the street and how it is perceived in the community. Education Village adds college-age students, as well as professional educators to the downtown mix which is a demographic group sought by vendors not now evident in the downtown core, such as bookstores, coffee shops, and venues for jazz and alternative music. By adding more students and instructors to the downtown streetscape, National City will be more attractive to new investors and retail and entertainment providers. In addition, programming usually associated with a college campus, such as

Figure 2-2: Downtown National City Destinations

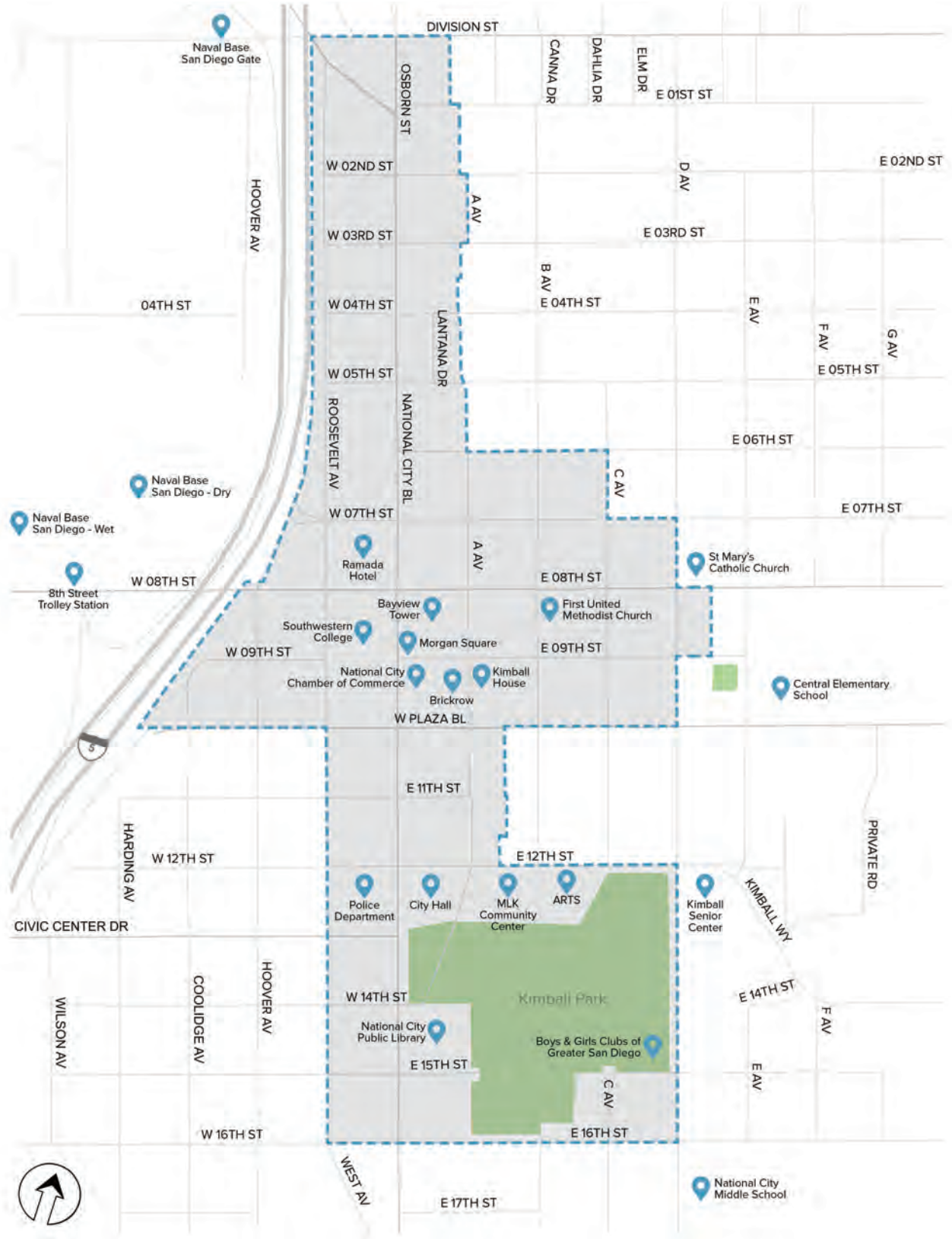

an emphasis on the visual and performing arts, will add another hue to the downtown palette. Along with the public library near Kimball Park, Education Village anchors downtown as a center of culture, learning, and elevated discourse. The Education Village was completed in 2005, which includes Southwestern College's Higher Education Center, a SDCOE South County Regional Education Center, retail and a parking garage. The library and the central fire station nearby, as well as the Police Headquarters and City Hall, fortify downtown as the institutional heart of the city.

The private sector is also active in improving downtown, with the remodeling of the 11-story former Red Lion hotel (now Bayview Towers), Harborview Condominiums on 8th Street and D Avenue, and the Centro Apartments on 12th Street and A Avenue. The remodel included substantial and well-considered street improvements that serve to weave together the diverse elements of the downtown with a streetscape of unified design and enhanced character.

2.3 DESCRIPTION OF THE PLANNING AREA

For the purposes of this Specific Plan the Specific Plan planning area (Planning Area) is defined as an area roughly bounded by Division Street, Roosevelt Avenue, 16th Street, D Avenue, Plaza Boulevard, Kimball Park, and Interstate 5 (Figure 2-3). These boundaries have been assigned in order to allow the plan to address the key portals into the core, define areas of complimentary uses, and help underpin some of the opportunities and assets within the Planning Area. As is outlined in following chapters, this Specific Plan has been developed with great attention to existing conditions and a commitment to achievable results.

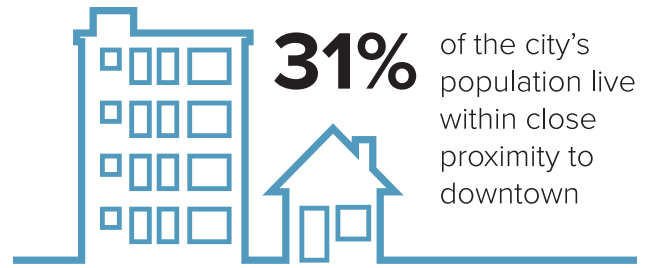

2.4 DEMOGRAPHIC PROFILE

It is essential that any program for the revitalization of downtown National City be built upon a foundation of solid analysis that ascertains what can reasonably be achieved. Therefore, a vital component of this planning effort is the economic overview of the Planning Area and the region within which it exists. The following chapter examines how the downtown functions as an economic engine and recommends focusing on certain areas for planning and development emphasis. The recommendations contained herein have been carried forward in subsequent chapters and have guided the development of the land use plan, landscape and streetscape concepts and the design guidelines.

Downtown National City consists of established residential neighborhoods, commercial businesses located along major streets, an education village, institutional uses and a mix of light industrial and commercial businesses. The downtown core is defined as the blocks between Plaza Boulevard and 7th Street and Roosevelt and D Avenues where most of the downtown's retail and service businesses are located.

About 18,700 residents live within a half mile downtown, or about 31 percent of the city's population. The households who live downtown tend to be older and less affluent. Homes downtown tend to be priced similarly to the rest of National City, although they tend to be smaller in size.

Downtown residents reflect the cultural diversity of National City, and many of the downtown businesses are owned and/or staffed by members of the Hispanic and Asian communities. Many fami-

Figure 2-3: Downtown National City Specific Plan Area

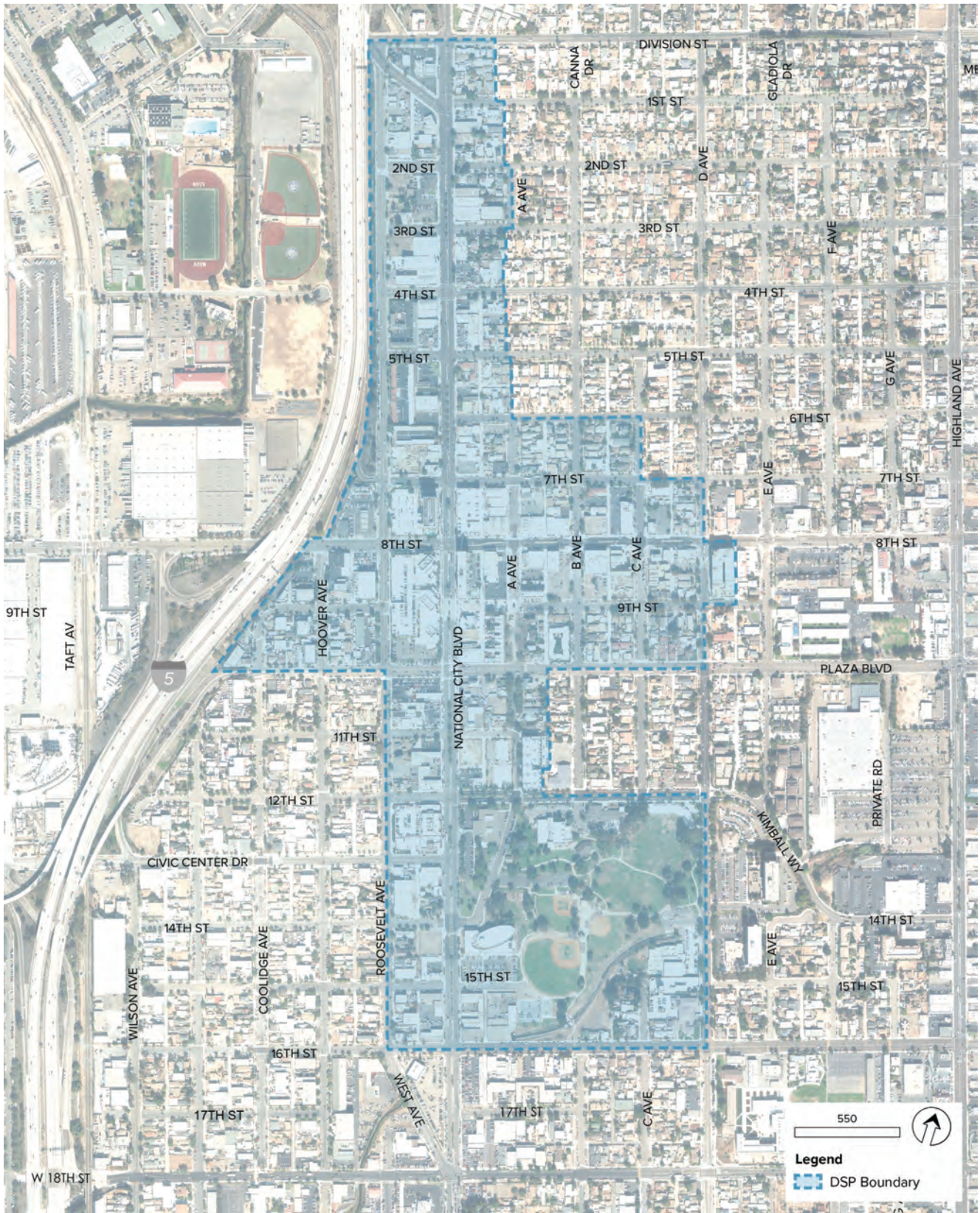

lies with children live downtown, often within extended families. About one fifth of the city's senior population lives downtown.

Most of the retail stores in downtown sell groceries, home furnishings, used merchandise, and auto and appliance parts. Sid's Carpet Barn has a regional draw and there are also several used automobile businesses, and the city's "Mile of Cars" is directly adjacent to downtown.

Downtown has numerous eating establishments; the highest volume eating establishments are Mc-Dinis, Napoleone Pizza House, Oriental Café, and Jack in the Box.

Niederfranks Ice Cream is both an ice cream shop and a wholesaler of natural, European style ice cream sold throughout the San Diego area.

Downtown also has a concentration of service businesses. Numerous health-related businesses, including medical, dental, acupuncture and chiropractic offices are clustered in the downtown core. There are also many personal service businesses, including beauty salons, barbershops, insurance, accounting, and attorneys. In addition, downtown businesses repair automobiles, appliances, and office equipment. Two major banks, Bank of America and Union Bank are located along 8th Street in the downtown core. Downtown has several lodging establishments, with the largest being the Ramada San Diego National City Hotel and the Howard Johnson Express.

National City has made substantial public investments in downtown. All of the city's administrative functions are located in the civic center, adjacent to the city's largest park, Kimball Park. The city's main library and police station are also located in the downtown. The City has provided substantial public funds to help restore the historic buildings along Brick Row and to construct the new Chamber of Commerce building. The City has acquired properties and helped redevelop them. Prime examples are housing, like the row houses along 9th Street and the senior towers next to Kimball Park. The City has also invested in the new Ed-

ucation Village. The City has also invested in a landscaping and streetscape program along National City Boulevard's Mile of Cars to the south of downtown.

The regional transit authority has invested in a light rail system linking National City to many parts of San Diego County, and two light rail transit stops are located near downtown. Improvements were made to enhance the connection of the trolley stop to downtown.

Downtown National City has many existing assets: its diverse residential population of families and seniors, numerous civic, educational and recreational amenities, broad variety of established businesses, and a strong employment base. The challenge for downtown's future is to efficiently and effectively leverage these assets into a vibrant, urban core that serves the existing population and encourages new residents and businesses to locate downtown.



National City Mile of Cars

2.5 ECONOMIC CONSIDERATIONS FOR THE SPECIFIC PLAN

The Specific Plan is designed to build upon and enhance existing assets. The economic considerations for the Specific Plan are to:

- Encourage private investment to compliment downtown businesses and the existing neighborhood fabric.
- Build on public investment in the Education Village, Chamber of Commerce, Brick Row, Kimball Park, National City Boulevard and the Transit Station from downtown.
- Enhance the pedestrian environment and provide public parking in the downtown core.
- Focus pedestrian-oriented retail in the downtown core on 8th Street and on National City Boulevard between 7th and 12th.
- Capture the potential for neighborhood, food related and specialty retail.
- Encourage mixed-use, residential over retail and developments in the downtown core.



Brick Row

2.5.1 POTENTIAL RETAIL MARKET

As shown in Table 2-1, according to the SANDAG data, there are approximately 2,182 residents in the downtown area in 2016, given that little new development has occurred. About 200 seniors live downtown and a large number of families with children occupy the single-family homes, row houses, and apartments. There is a higher concentration of seniors who live in the downtown as compared to the city as a whole.

Downtown businesses currently draw patronage from the surrounding neighborhoods, people who live in National City and surrounding communities, employees in both the public and private sectors, and other businesses within downtown.

Downtown businesses that attract patrons from outside the immediate neighborhood include the Holiday Inn and Red Lion, two banks, restaurants, and specialty shops. In addition, churches located in downtown attract people from the broader region.

Typically, neighborhood retail businesses draw patronage from a one-mile radius. About 33,000 people currently live within a one-mile radius on the downtown.



There are approximately
2,182
residents in
downtown

Furthermore, about 54,000 people work within a one-mile radius of the downtown. Most workers are employed by the federal government at the Navy base and by the City in the Civic Center. However, about 9,934 workers are employed by the private sector primarily in retail trade, services, manufacturing, and wholesale trade.

Regionally oriented businesses typically draw patronage from a three to five-mile radius of the downtown. About 479,000 people live within a five-mile radius of downtown, and about 281,000 people work within a five-mile radius of downtown, working in both the public and private sector in federal government, local government, service, retail, trade, manufacturing and finance, insurance, and real estate industries.

Table 2-1: Planning Area Demographics

Category	DSP	National City
Resident population (SANDAG Current Estimates, 2016)	2,182	60,768
Senior population (US Census 2015 ACS Estimates)	212	6,407
Seniors as percent of population (US Census 2015 ACS Estimates)	10%	11%
Number of households (US Census 2015 ACS Estimates)	553	14,819
Average household size (US Census 2015 ACS Estimates)	3.2	3.6
Average age (US Census 2015 ACS Estimates)	32	34
Average income (US Census 2015 ACS Estimates)	\$30,081	\$43,897
Average home value (US Census 2015 ACS Estimates)	\$238,267	\$280,893
% of households with income > \$75,000 (US Census 2015 ACS Estimates)	16%	20%
Residents within 1/2-Mile Radius of Downtown	18,700	31%
Residents within 1-Mile Radius of Downtown	37,500	62%
Employed within 1-Mile Radius of Downtown		

Source: Claritas, LLC 2017

Table 2-2: Current Household Expenditures for Households

Category	Within One Mile Radius	Within Three Mile Radius	Within Five Mile Radius
Food At Home	\$4,719	\$4,783	\$4,588
Food Away from Home and Alcohol	\$4,995	\$5,138	\$5,715
Day Care, Education & Contributions	\$2,795	\$3,112	\$4,227
Healthcare	\$4,134	\$4,334	\$4,507
Household Furnishings & Appliances	\$1,363	\$1,508	\$1,760
Housing Related & Personal	\$9,904	\$10,748	\$11,320
Personal Care & Smoking Products	\$1,368	\$1,477	\$1,676
Pet Expenses	\$323	\$364	\$424
Sports & Entertainment	\$2,755	\$2,999	\$3,598
Transportation & Auto Expenses	\$9,026	\$10,600	\$11,198
Apparel	\$2,074	\$2,141	\$2,144
Total	\$43,456	\$47,204	\$51,157

Source: Claritas, LLC 2017

Table 2-3: Downtown National City Expenditure Potential

Category	Average Annual Household Expenditures Within Five Miles	Potential Buying Power Based on Average Annual Household Expenditures Multiplied by 5,500 Residential Units	Potential Supportable Space (Sq Ft) Based on Potential Buying Power Divided by \$200/Sq Ft
Food At Home	\$4,588	\$25,234,000	126,170
Food Away from Home and Alcohol	\$5,715	\$31,432,500	157,163
Housing Related & Personal	\$11,320	\$62,260,000	311,300
Personal Care & Smoking Products	\$1,676	\$9,218,000	46,090
Apparel	\$2,144	\$11,792,000	58,960
Total	\$25,443	\$139,936,500	699,683

Source: Claritas, LLC 2017

Downtown is projected to grow about 4% over the next five years, while the greater region within the five-mile radius is projected to grow faster at about 4.5% percent over the next 5 years. New housing proposed for the Specific Plan will stimulate additional growth in population within the one-mile radius.



5,500

new housing units
could house up to

Table 2-2 shows the current household expenditures for households that live within one, three, and five-mile radius of the downtown. Households typically spend between \$8,000 and \$9,000 per year on food related items, including groceries and eating establishments; between \$3,000 to \$4,000 per year on apparel and about \$2,000 per year on specialty items and miscellaneous goods. The downtown could potentially capture a significant proportion of these household expenditures.

Based on land use projections, the Specific Plan could encourage the development of up to 5,500 new housing units (300 units have been built at the time of the Specific Plan's approval) that could potentially house about 10,400 new residents, at an average household size of 2 persons. These new households could generate demand for about 699,683 square feet of new retail space, as shown in Table 2-3. However, the amount of new retail space that can be supported in the future will depend upon how much the downtown new household expenditures, as well as how much it can attract residents and workers from the greater region.



3

LAND USE, ZONING, AND DEVELOPMENT STANDARDS

3.1 INTRODUCTION

The purpose of this chapter is to create an appropriate and functional mix of uses within the Planning Area. The land use and development standards are intended to enhance the commercial corridors and create central gathering places, as well as to facilitate infill development, transit use, tourism, and the revitalization of the entire downtown area. The mix of land uses and high-density enables people to live in close proximity to work, transit, recreational opportunities, shops, restaurants, entertainment venues, and civic places. This allows residents of downtown to be within a short walking distance of all of these amenities. This aids in decreasing driving, therefore reducing greenhouse gas emissions and increasing the health benefits of walking/biking, and encouraging social interaction. Plazas, shops, parks, and mixed-use developments will promote cultural, social, civic, and commercial activities, creating new opportunities for local tourism and transforming downtown National City into a regional destination.

An important factor in creating a vital downtown is having a mix of land uses at an appropriate density. Most of the development zones allow and encourage a mix of land uses. There are also minimum FARs which ensure that there is at least a minimum level of density. It is also important to respect the existing lower-scale density on the edges of downtown and appropriately scale back development adjacent to lower-scale development. The development regulations encourage this by only allowing residential in certain zones and requiring a less dense, lower-intensity development adjacent to existing lower-scale development.

3.2 HOUSING

To create a successful, vibrant downtown, housing should be encouraged. California Government Code Title 7. Planning and Land Use [65000-66499.58], Div.1. Planning and Zoning [65000-66103], Chapter 4.3 Density Bonus and other incentives [65915-65918], are available for developers and assists in providing more attainable housing.

The Specific Plan has the following policies/standards to assist in adding to the supply of affordable housing units:

- The preservation of housing and naturally occurring affordable housing (NOAH).
- The reduction of parking requirements. The Specific Plan establishes a parking bonus system for off-street parking/shared parking that reduces parking requirements or awards bonus units to developers that work to reduce VMT and promote TDM.
- The providing of a more streamlined review process: It is recommended to allow residential and/or commercial projects that are in conformance with the Municipal Code to be approved through a ministerial process. This is to encourage urban infill projects by shortening the process and allowing some surety in the development review.
- The encouragement of smaller units by restructuring Developer Impact Fees (DIFs). It is recommended that the calculation of DIFs is changed to being based on square footage of the unit, rather than being based on the number of units. Changing to a square footage metric provides a greater incentive to a developer to build fewer larger units, therefore increasing the supply of smaller units.

3.3 TRANSFER OF DEVELOPMENT RIGHTS

Transfer of Development Rights (TDR) is a voluntary, incentive based program that allows landowners to sell development rights from their land to a developer or other interested party who then can use these rights to increase the density of development at another designated location. The Specific Plan allows for TDR as long as the proposed development using the development rights still conforms to the City's codes and policies such as the Municipal Code, General Plan, Specific Plan, and CEQA. It is advised to meet with City planning staff before embarking on a TDR process.

3.4 GENERAL PLAN GOALS AND POLICIES AFFECTING THE SPECIFIC PLAN

The following goals and policies have been included in this document to set the context for recommendations. These are directly taken from the 2012 General Plan Update.

3.4.1 SMART GROWTH AND REGIONAL PLANNING

Goal LU-1: Smart growth that is consistent with statewide and regional transportation and planning goals and policies.

Policy LU-1.2: Concentrate commercial, mixed-use, and medium to high density residential development along transit corridors, at major intersections, and near activity centers that can be served efficiently by public transit and alternative transportation modes.

Policy LU-1.4: Work with SANDAG to ensure that applicable transit priority and residential or mixed-use projects may benefit from California Environmental Quality Act (CEQA) streamlining pursuant to SB375.

Policy LU-1.5: Consider the effects of land use proposals and decisions on the region and efforts to maintain a jobs-housing balance.

Policy LU-1.6: Enable residents to reduce their commutes by supporting telecommuting, satellite work centers, and home occupations that are compatible with adjacent or surrounding properties.

3.4.2 MIX OF LAND USES

Goal LU-2: A mix of land uses including residential, commercial, employment, service, agricultural, open space, and recreational uses that accommodate the needs of persons from all income groups and age levels.

Policy LU-2.1: Provide for housing near jobs, transit routes, schools, shopping areas, and recreation to discourage long commutes; promote public transit, walking, and biking; and lessen traffic congestion.

Policy LU-2.2: Allow for density bonuses and other incentives to encourage mixed-use development projects in mixed-use designations.

Policy LU-2.3: Provide for a variety of housing types including, but not limited to, single-family attached and detached, multifamily apartments, condominiums, and mobile homes.

Policy LU-2.4: Provide additional recreational open space areas and connect these areas to trails, bikeways, pedestrian corridors, and other open space networks, where feasible.

Policy LU-2.5: Encourage the establishment of community farms and gardens.

Policy LU-2.6: Support development and redevelopment that creates jobs for all income levels.

Policy LU-2.7: Allow and encourage the creation of studios and workspaces for artists, craftspeople, and other professions and allow for self-employment and home occupations, where compatible with the desired neighborhood character.

Policy LU-2.8: Designate land for industrial uses sufficient to meet future city needs, but only in locations that will not negatively impact residential neighborhoods.

Policy LU-2.9: Designate land for commercial, office, and service uses sufficient to meet future city needs.

Policy LU-2.10: Encourage the development and expansion of institutions, such as schools and health care facilities, as needed to meet future city needs.

3.4.3 COMPATIBLE DEVELOPMENT

Goal LU-3: A land use pattern that avoids the creation and continuance of incompatible land uses.

Policy LU-3.2: Prevent the intrusion of new incompatible land uses and environmental hazards into existing residential areas and phase out existing non-conforming uses.

Policy LU-3.5: Preserve, protect, and enhance established neighborhoods by providing sensitive transitions between those neighborhoods and adjoining areas, and requiring new development to respect and respond to those existing physical characteristics, buildings, streetscapes, open spaces, and urban form that contribute to the overall character and livability of the neighborhood.

Policy LU-3.7: Limit impacts from industrial or mixed-uses by establishing performance standards to regulate noise, glare, vibrations, odor, lighting, air pollution, and other potential disturbances.

Policy LU-3.8: Allow non-conforming uses to continue, but do not encourage their enlargement, expansion, or extension unless they have been found not to be substantially impactful to the community and they provide an avenue of progressive change.

3.5 DEVELOPMENT ZONES

The Planning Area consists of 158 acres in downtown National City and it regulates the project area through the application of 16 development zones. Each development zone has its own land use regulations, development standards, and design guidelines. The boundaries of the development zones are shown in Figure 3-1. Land use regulations and development standards for each of the development zones are summarized in Table 3-1. Height restrictions are shown in Figure 3-2 and Figure 3-3.

Table 3-1: Land Use Regulations and Development Standards

Development Zone	Maximum FAR	Minimum FAR	Maximum Height	Maximum Number of Units ^{1,2}	Land Use																	
					Residential				Commercial					Other								
					Single Family Detached	Townhome	Medium Density	High Density	Mixed-Use	Motel	Hotel	Theaters & Cafés	Restaurants	Retail	Professional Office	Auto-Oriented Retail	Public Parking	Institutional/College	Light Industrial	Park/Plaza		
1A	6:1	3:1	250'	668				✓	✓	✓	✓	✓	✓	✓	✓	✓	✓	✓				
1B	6:1	3:1	250'	401					✓	✓	✓	✓	✓	✓	✓	✓	✓	✓				✓
2	4:1	2:1	75'	497			✓															
3	4:1	2:1	75'	90			✓		✓					✓								
4	6:1	3:1	250'	122				✓	✓					✓								
5A	3:1	None	50'	38		✓	✓		✓													
5B	4:1	2:1	90'	75			✓		✓					✓								
6	6:1	3:1	250'	263				✓	✓	✓	✓	✓	✓	✓	✓	✓						
7	6:1	3:1	250'	379				✓	✓	✓	✓	✓	✓	✓	✓	✓						
8	3:1	None	50'	130		✓																
9	5:1	2.5:1	90'	400				✓	✓			✓	✓	✓	✓							
10	3:1	None	50'	235		✓	✓															✓
11	4:1	2:1	50'	212			✓															
12A	5:1	2.5:1	90'	232			✓	✓	✓	✓	✓	✓	✓	✓	✓							
12B	4:1	2:1	65'	-			✓		✓	✓	✓			✓								
13	4:1	2:1	75'	52			✓															
14	4:1	2:1	75'	306			✓															
15	Kimball Park																					
16	Civic Center																					

¹The maximum unit threshold is a maximum total number of units for the entirety of the development zone, not per project. If the maximum units are reached in a development zone, then the project will be considered discretionary and will require a traffic analysis.

²The total number of units equals 4,100 because the EIR assumes a 75 percent build-out of the 5,500 maximum total.

Figure 3-1: Development Zones

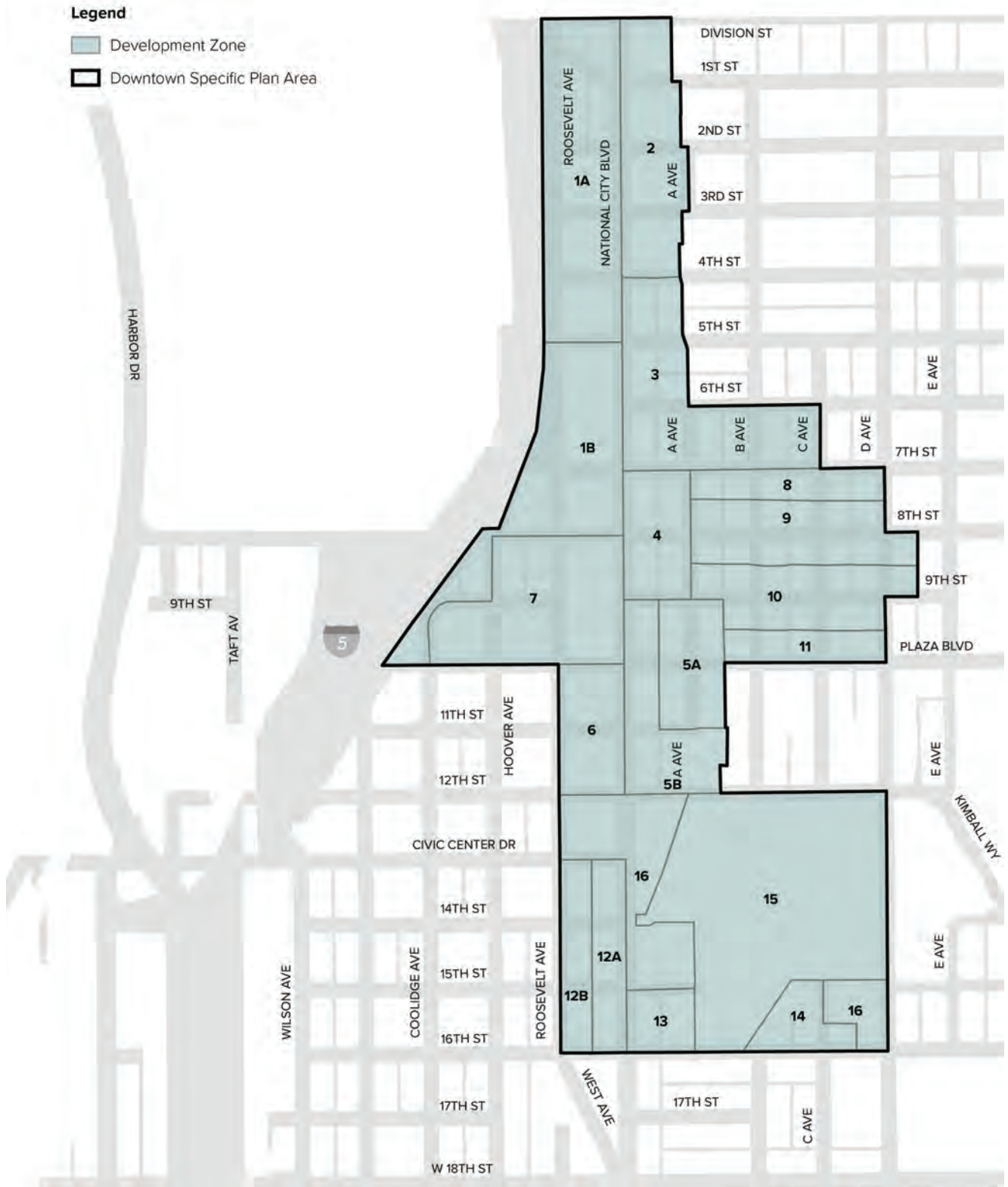

Figure 3-2: Height Restrictions

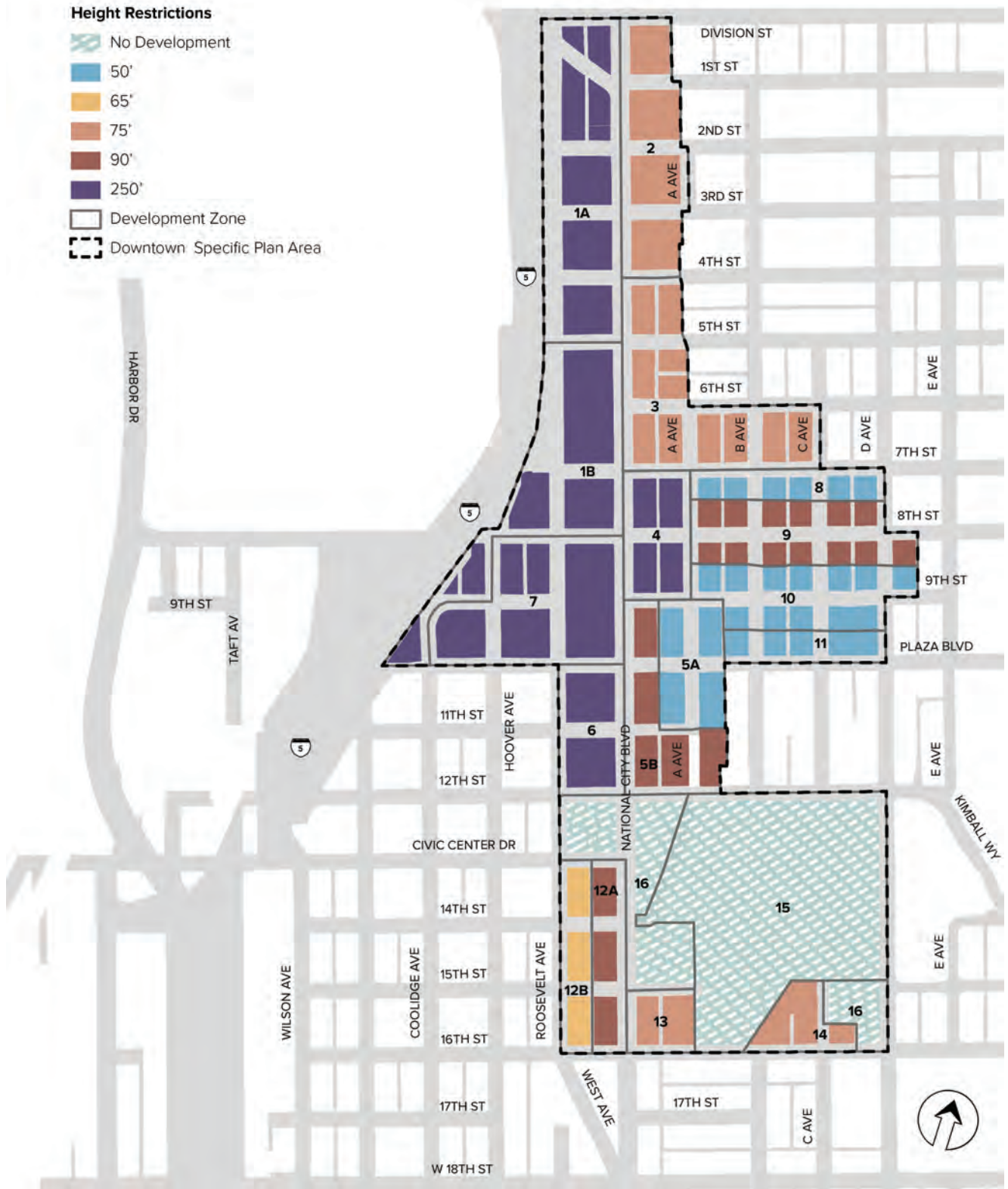
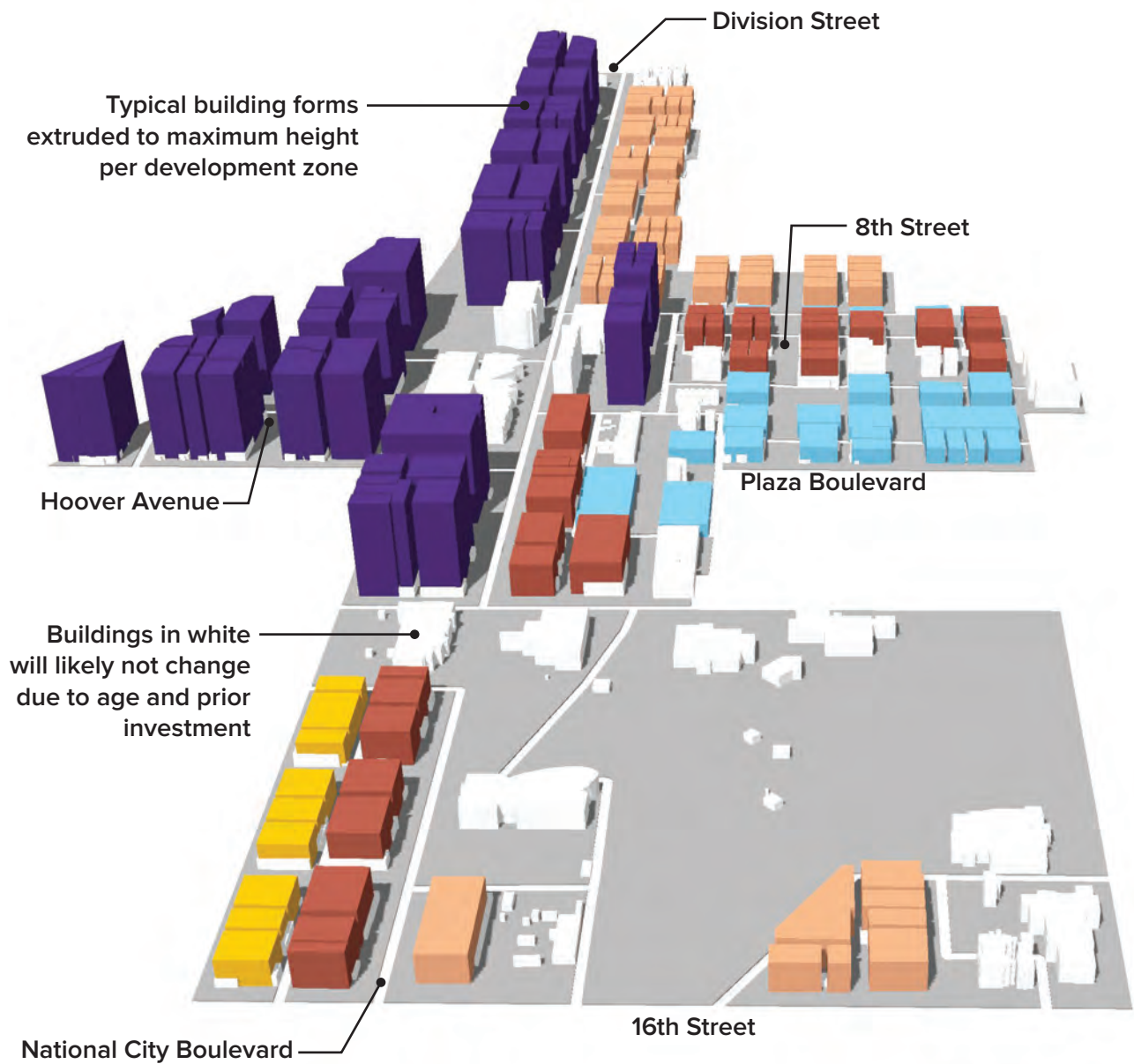

Figure 3-3: Height Restrictions 3D Model



3.5.1 DEVELOPMENT ZONE 1A AND 1B

3.5.1.1 Development Intensity

Floor Area Ratio: 6:1 maximum/3:1 minimum

Maximum Height: 250'

Unless otherwise stated, the development standards of the Major Mixed Use Corridor (MXC-2) zone shall apply.

Maximum Number of Units for 1A: 668

Maximum Number of Units for 1B: 401

If maximum number of units is exceeded per zone, a traffic analysis and/or CEQA review may be required. Project would require discretionary review.

3.5.1.2 General Guidelines:

This area, adjacent to the downtown core, is proposed for retail, entertainment or employment uses. These uses may be mixed either horizontally or vertically or developed on a parcel-by-parcel or block-by-block basis. Development may be "auto-oriented" but National City Boulevard is to have a pedestrian orientation. Mixed-use developments are highly encouraged.

Since this development zone is part of the "gateway" to downtown, and National City Boulevard is intended to be its primary "ceremonial" artery, every effort should be made to strengthen the definition, streetscape and pedestrian character of National City Boulevard's pedestrian streetscape.

3.5.1.3 Permitted Uses:

Mid-high rise, multi-family residential, commercial, residential and visitor serving commercial (hotel, motel, restaurants), entertainment uses (theaters, clubs), light Industrial manufacturing, auto-oriented retail, professional offices, and public parking.

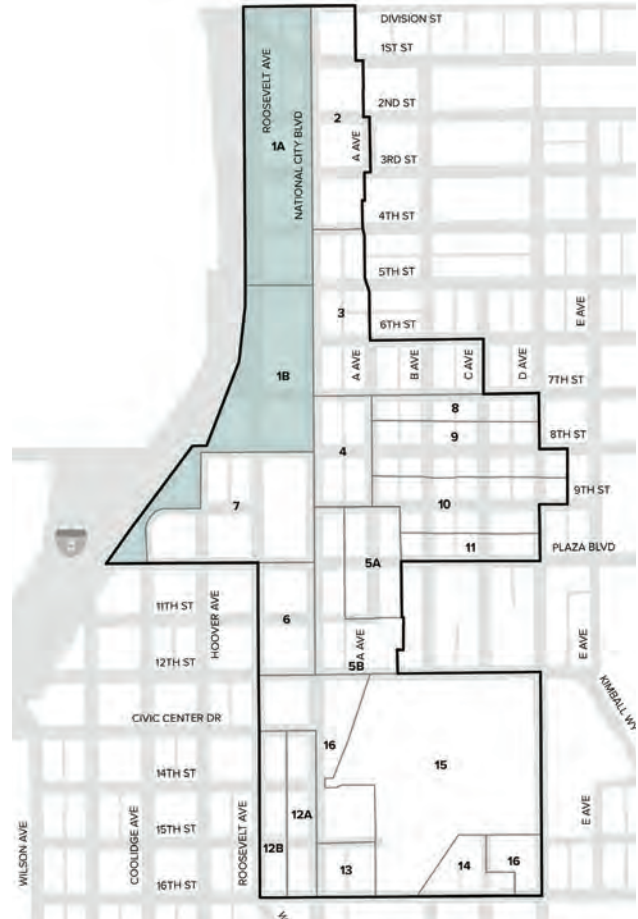

3.5.2 DEVELOPMENT ZONE 2

3.5.2.1 Development Intensity

Floor Area Ratio: 4:1 maximum/2:1 minimum

Maximum Height: 75'

Unless otherwise stated, the development standards of the Major Mixed Use Corridor (MXC-2) zone shall apply.

Maximum Number of Units: 497

If maximum number of units is exceeded per zone, a traffic analysis and/or CEQA review may be required. Project would require discretionary review.

3.5.2.2 General Guidelines:

This is the zone along the east side of National City Boulevard, extending from Division Street to 4th Street, and eastward to A Avenue or a comparable property boundary. The Specific Plan calls for this area to be developed with medium-density residential use. These are relatively large parcels that lend themselves to self-contained multi-family projects. Since this development zone abuts an established single-family neighborhood, projects should be designed to afford a comfortable transition. National City Boulevard should be addressed as the primary frontage for these parcels, and the pedestrian scale and character of the Boulevard should be enhanced. Semi-public building areas, such as residential lobbies, should be accessible from the Boulevard, and front porch "stoops" or small entry courtyards are encouraged at the street frontage. A "build-to" line is required be maintained on National City Boulevard and all other streets in order to define the street edge and reinforce the pedestrian character of the streetscape leading to the downtown core.

3.5.2.3 Permitted Uses:

Medium density multi-family residential and shopkeeper units.

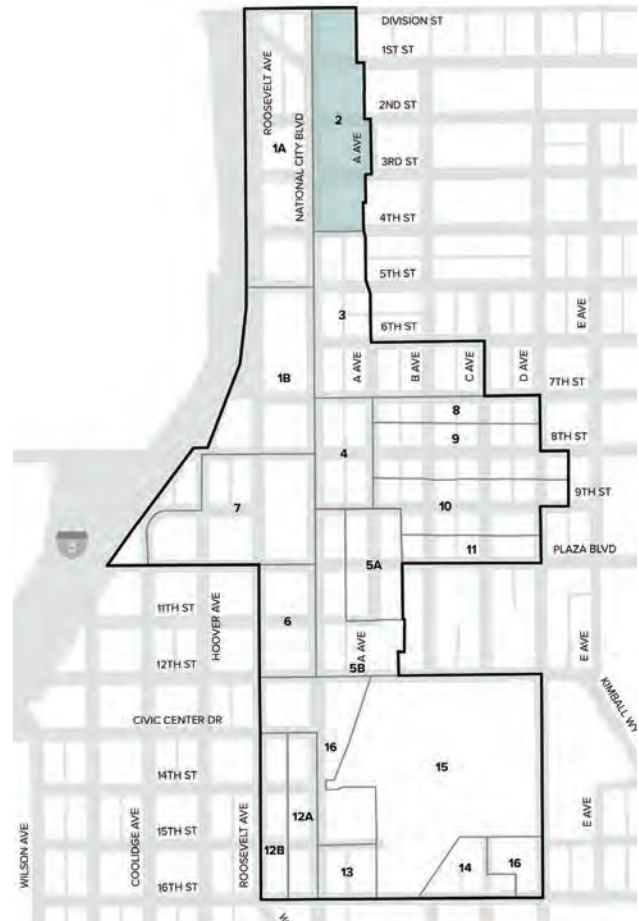

3.5.3 DEVELOPMENT ZONE 3

3.5.3.1 Development Intensity

Floor Area Ratio: 4:1 maximum/2:1 minimum

Maximum Height: 75'

Unless otherwise stated, the development standards of the Major Mixed Use Corridor (MXC-2) zone shall apply.

Maximum Number of Units: 90

If maximum number of units is exceeded per zone, a traffic analysis and/or CEQA review may be required. Project would require discretionary review.

3.5.3.2 General Guidelines:

This is the National City Boulevard frontage from 4th to 7th Street, extending eastward to the existing alley. This zone is proposed for medium-density residential development, with street-oriented retail at grade. In contrast to Development Zone 2, farther north on National City Boulevard, this zone is composed of smaller parcels that lend themselves to smaller-scaled projects, composed of apartments and row homes. Since this area is quite close to the main shopping district on 8th Street, pedestrian-oriented retail, service, and restaurant facilities are encouraged. A "build-to" line is required on National City Boulevard and other streets in order to define the street edge and reinforce the pedestrian character and vitality of the streetscape leading to the downtown core.

3.5.3.3 Permitted Uses:

Medium density multi-family residential (at least 50 percent of development) with street-level retail.

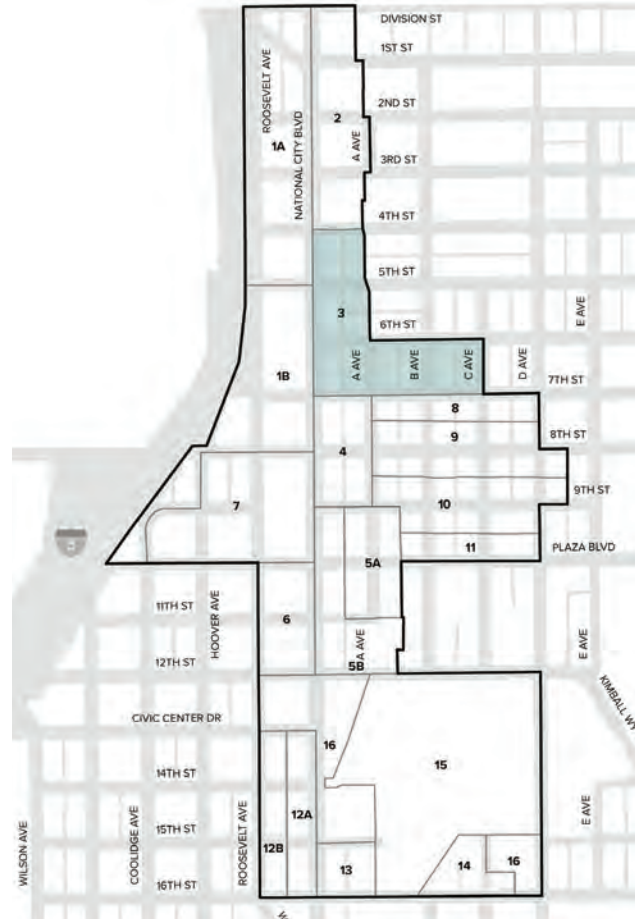

3.5.4 DEVELOPMENT ZONE 4

3.5.4.1 Development Intensity

Floor Area Ratio: 6:1 maximum/3:1 minimum

Maximum Height: 250'

Unless otherwise stated, the development standards of the Major Mixed Use Corridor (MXC-2) zone shall apply.

Maximum Number of Units: 122

If maximum number of units is exceeded per zone, a traffic analysis and/or CEQA review may be required. Project would require discretionary review.

3.5.4.2 General Guidelines:

This is the area between National City Boulevard, A Avenue, 7th and 9th Streets. The zone includes the existing Bayview Towers building and parking structure, as well as several commercial structures along A Avenue. Mixed-use is strongly encouraged.

3.5.4.3 Permitted Uses:

Medium-density, multi-family residential, and street-oriented retail.

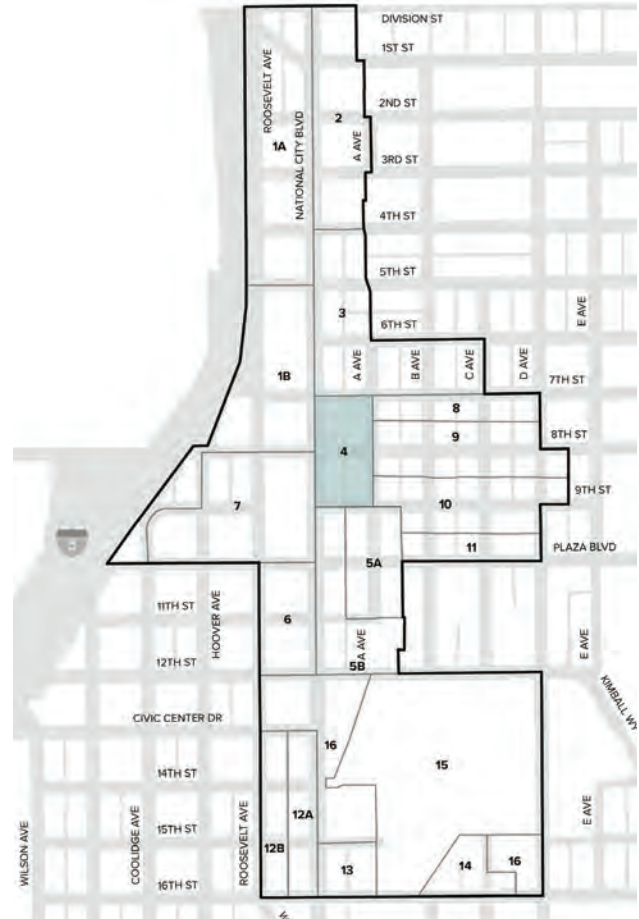

3.5.5 DEVELOPMENT ZONE 5A AND 5B

3.5.5.1 5A Development Intensity

Floor Area Ratio: 3:1 maximum

Maximum Height 50'

Maximum Number of Units: 38

If maximum number of units is exceeded per zone, a traffic analysis and/or CEQA review may be required. Project would require discretionary review.

3.5.5.2 5B Development Intensity

Floor Area Ratio: 4:1 maximum/2:1 minimum

Maximum Height: 90'

Maximum Number of Units: 75

If maximum number of units is exceeded per zone, a traffic analysis and/or CEQA review may be required. Project would require discretionary review.

3.5.5.3 General Guidelines:

Development Zone 5A encompasses the eastern half of the two-block area fronting on A Avenue, and contains the historic Brick Row town- homes, which are a major component of National City's Downtown historic core. Development along A Avenue from Plaza to 12th Street should be two or three-story row homes complementing Brick Row and other historic structures on the east side of A Street, and continuing the scale of this development to create a strong pedestrian connection to Kimball Park.

Development Zone 5B includes the Trophy Lounge site and the Chamber of Commerce building. The frontages on National City Boulevard from Plaza to 12th Street should be developed as medium-density residential over street-oriented retail. Retain and enhance existing civic, historic and redeveloped commercial uses.

3.5.5.4 5A Permitted Uses:

Medium-density multi-family residential over street-level retail on National City Boulevard and row homes on A Avenue.

3.5.5.5 5B Permitted Uses:

Residential over street-level retail.

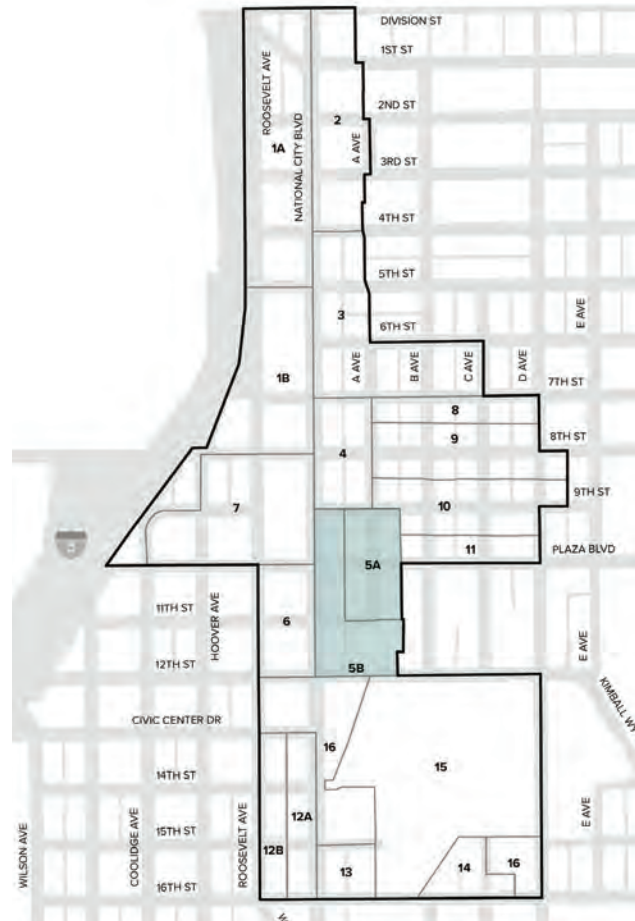

3.5.6 DEVELOPMENT ZONE 6

3.5.6.1 *Development Intensity*

Floor Area Ratio: 6:1 maximum/3:1 minimum

Maximum Height: 250'

Unless otherwise stated, the development standards of the Major Mixed Use Corridor (MXC-2) zone shall apply.

Maximum Number of Units: 263

If maximum number of units is exceeded per zone, a traffic analysis and/or CEQA review may be required. Project would require discretionary review.

3.5.6.2 *General Guidelines:*

This zone, currently occupied by a mix of residential, commercial, and light industrial uses, is proposed for higher density mid-rise multi-family residential, hotel or professional office development, with ground floor pedestrian-oriented retail and/or office along National City Boulevard and along Roosevelt Avenue. These parcels are farther from the pedestrian-scale shopping activity on 8th Street and from the adjacent single-family neighborhoods, so greater density and height is encouraged. These development sites also offer the potential for long views to the bay from upper floors. Primary uses envisioned for these parcels are multi-family residential, but the parcels may also be developed as mixed-use, with a combination of residential, office, and hospitality uses.

3.5.6.3 *Permitted Uses:*

Mid-rise multi-family residential, street-oriented retail, office, and/or hospitality (retail uses should not exceed 20 percent of the total development).

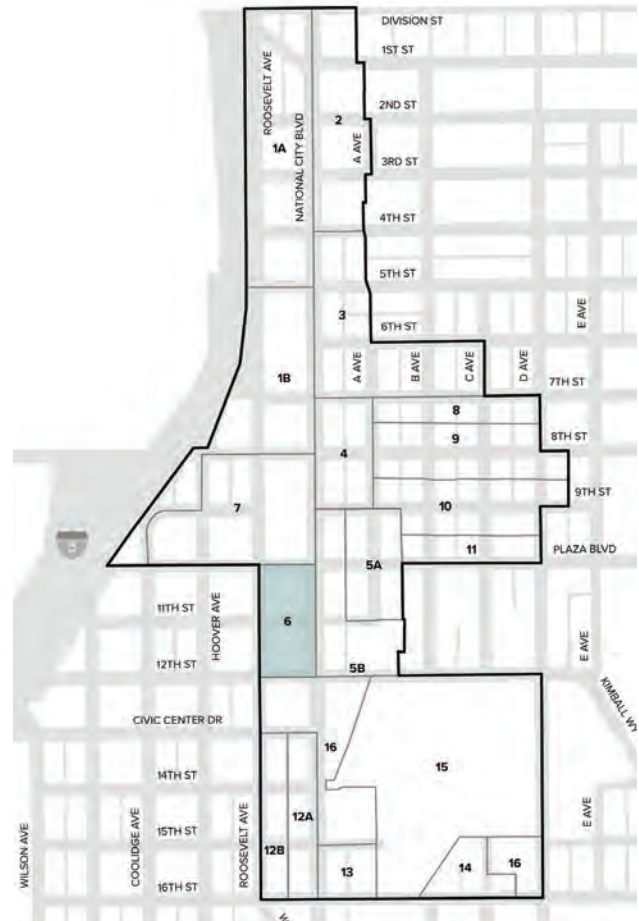

3.5.7 DEVELOPMENT ZONE 7

3.5.7.1 Development Intensity

Floor Area Ratio: 6:1 maximum/3:1 minimum

Maximum Height: 250'

Unless otherwise stated, the development standards of the Major Mixed Use Corridor (MXC-2) zone shall apply.

Maximum Number of Units: 379

If maximum number of units is exceeded per zone, a traffic analysis and/or CEQA review may be required. Project would require discretionary review.

3.5.7.2 General Guidelines:

This zone, currently occupied by a mix of residential, commercial, and light industrial uses, is proposed for higher density mid-rise multi-family residential, hotel or professional office development, with ground floor pedestrian-oriented retail, and/or office along National City Boulevard and along Roosevelt Avenue where it borders the Education Village complex. These parcels are further from the pedestrian-scale shopping activity on 8th Street and from the adjacent single-family neighborhoods, so greater density and height is encouraged. These development sites also offer the potential for long views to the bay from upper floors. Primary land use envisioned for these parcels is multi-family residential, but they may also be developed as mixed-use, with a combination of residential, office, and hospitality uses.

3.5.7.3 Permitted Uses:

Mid-rise multi-family residential, street-oriented retail, office, or hospitality (retail uses shall not exceed 20 percent of the total development).

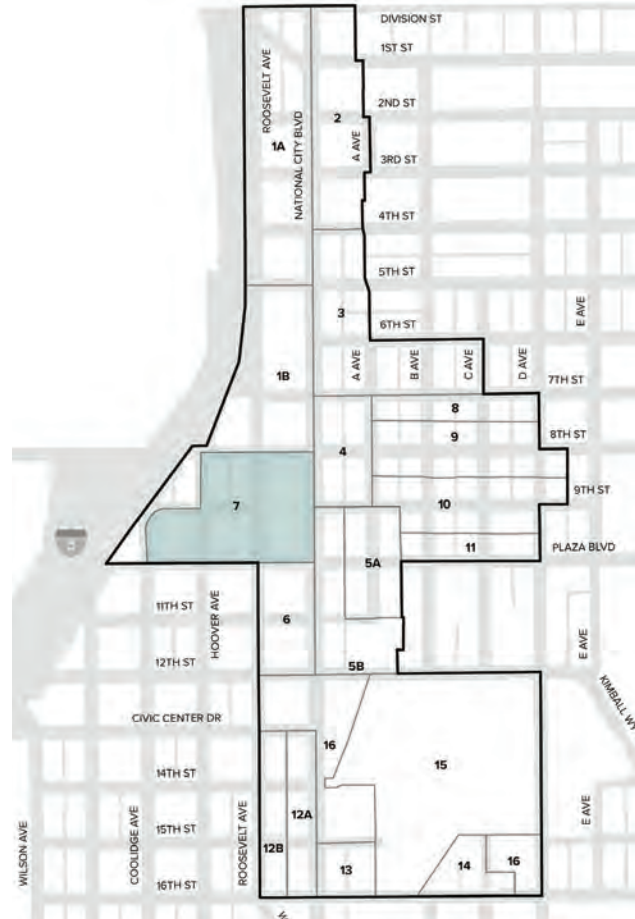

3.5.8 DEVELOPMENT ZONE 8

3.5.8.1 Development Intensity

Floor Area Ratio: 3:1 maximum

Height limit: 50'

Maximum Number of Units: 130

If maximum number of units is exceeded per zone, a traffic analysis and/or CEQA review may be required. Project would require discretionary review.

3.5.8.2 General Guidelines:

This area forms a transition between the higher densities and activity levels on 8th Street and the quieter, smaller-scaled single family residential neighborhood to the north. It should be noted that this development zone consists of the northern portions of three city blocks, the southern portions of which are designated for higher densities. To the extent that a full-block development is planned for any of these parcels, the design should accommodate a lower-scaled, row home vernacular along the northern edge, even though the balance of the block is designed at a higher density.

3.5.8.3 Permitted Uses:

Multi-family.

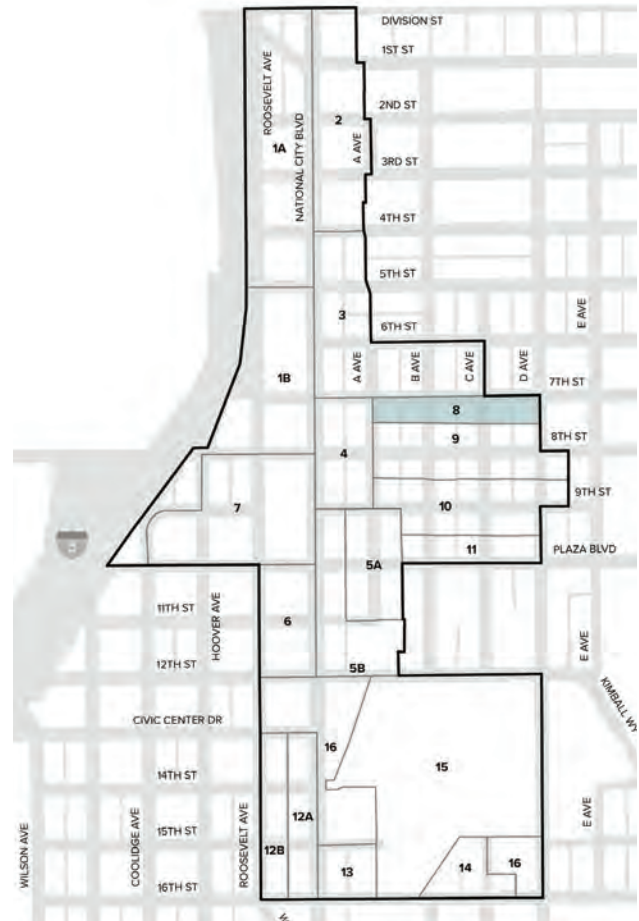

3.5.9 DEVELOPMENT ZONE 9

3.5.9.1 Development Intensity

Floor Area Ratio: 5:1 maximum/2.5:1 minimum

Maximum Height: 90'

Unless otherwise stated, the development standards of the Major Mixed Use Corridor (MXC-2) zone shall apply.

Maximum Number of Units: 400

If maximum number of units is exceeded per zone, a traffic analysis and/or CEQA review may be required. Project would require discretionary review.

3.5.9.2 General Guidelines:

It is important that development along 8th Street be mixed-use in nature, with a significant density of multi-family residential overlaying the ground-level retail. This will have the effect of creating a critical mass of residents who will view this development zone, and the entire downtown core, as their neighborhood. It is also important that the adaptive re-use of existing older buildings that are good examples of architecture of that period be pursued.

The Specific Plan provides that mixed-use development along 8th Street will be of a moderate density and height. The objective is to provide a continuous street wall and a sense of definition and enclosure to the street-level activities, but not to overwhelm the development zone with tall structures.

3.5.9.3 Permitted Uses:

Mixed-use, with a significant density of multi-family residential overlaying the ground-level retail.

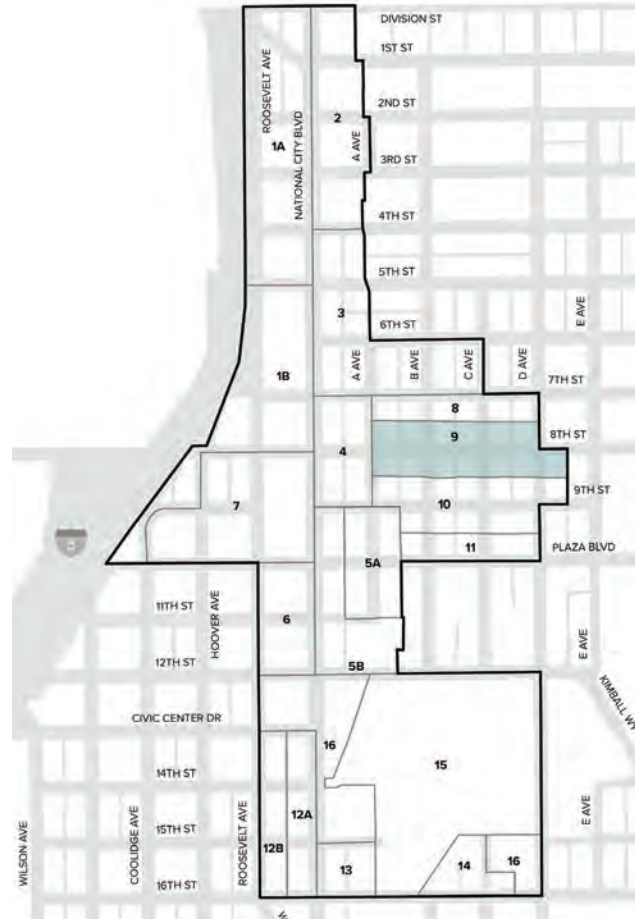

3.5.10 DEVELOPMENT ZONE 10

3.5.10.1 *Development Intensity*

Floor Area Ratio: 3:1 maximum

Maximum Height: 50'

Maximum Number of Units: 235

If maximum number of units is exceeded per zone, a traffic analysis and/or CEQA review may be required. Project would require discretionary review.

3.5.10.2 *General Guidelines:*

The Specific Plan proposes that 9th Street, between the elementary school to the east and the Education Village to the west, be developed as a quiet, urban residential street. This street forms an important east-west connection between two educational facilities and terminates at Fountain Square public space, just east of National City Boulevard.

Proposed development on both sides of 9th Street is with row homes, or similar architectural style, that is complementary in style and scale to the existing residences between A and B Avenues on the north side of 9th Street. 9th Street also forms an important linkage to Brick Row and Downtown's historic core. A Avenue provides an enhanced connection to Kimball Park.

It should be noted that this development zone consists of portions of six city blocks, the balance of which are designated for higher densities. To the extent that a full-block development is planned for any of these six parcels, the design should accommodate a lower-scaled row home or similar vernacular along the 9th Street frontage, even though the balance of the block is designed at a higher density.

3.5.10.3 *Permitted Uses:*

Multi-family residential.

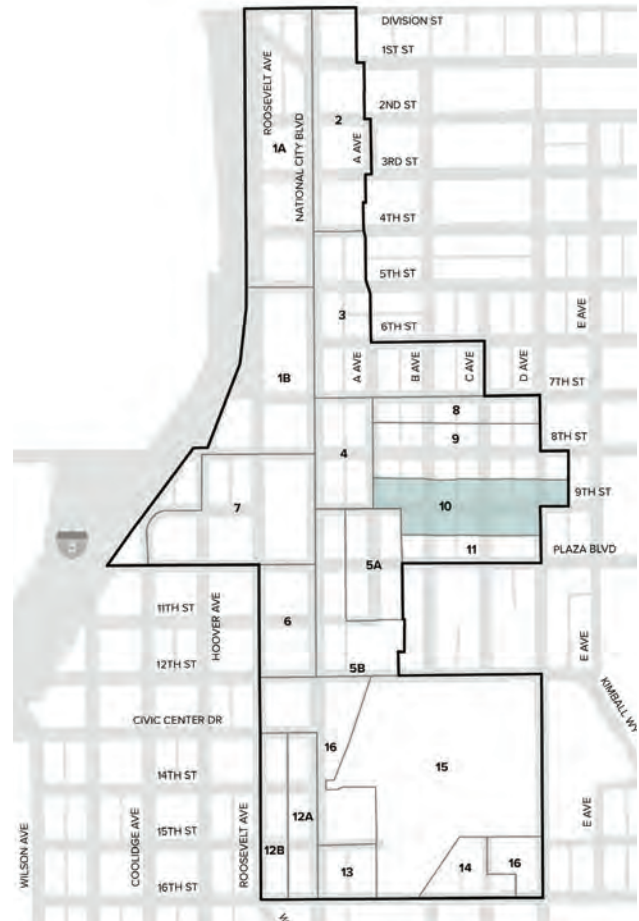

3.5.11 DEVELOPMENT ZONE 11

3.5.11.1 Development Intensity

Floor Area Ratio: 4:1 maximum/2:1 minimum

Maximum Height: 50'

Unless otherwise stated, the development standards of the Major Mixed Use Corridor (MXC-2) zone shall apply.

Maximum Number of Units: 212

If maximum number of units is exceeded per zone, a traffic analysis and/or CEQA review may be required. Project would require discretionary review.

3.5.11.2 General Guidelines:

Plaza Boulevard is heavily used and its traffic volumes will increase as it takes on additional volume that will be diverted from 8th and 9th Streets under the guidelines of the Specific Plan. It will essentially become an east-west "bypass" to support the strengthened pedestrian emphasis of 8th and 9th streets. The area to the south of Plaza Boulevard is an established residential neighborhood consisting of single-family and multi-family dwellings.

The Specific Plan proposes that the frontage on the north side of Plaza Boulevard, between A and D Avenues be developed with medium-density multi-family residential use, similar in density, scale and character to that designated for the same zone on 8th Street, but absent ground-level retail uses.

3.5.11.3 Permitted Land Uses:

Medium-density multi-family residential.

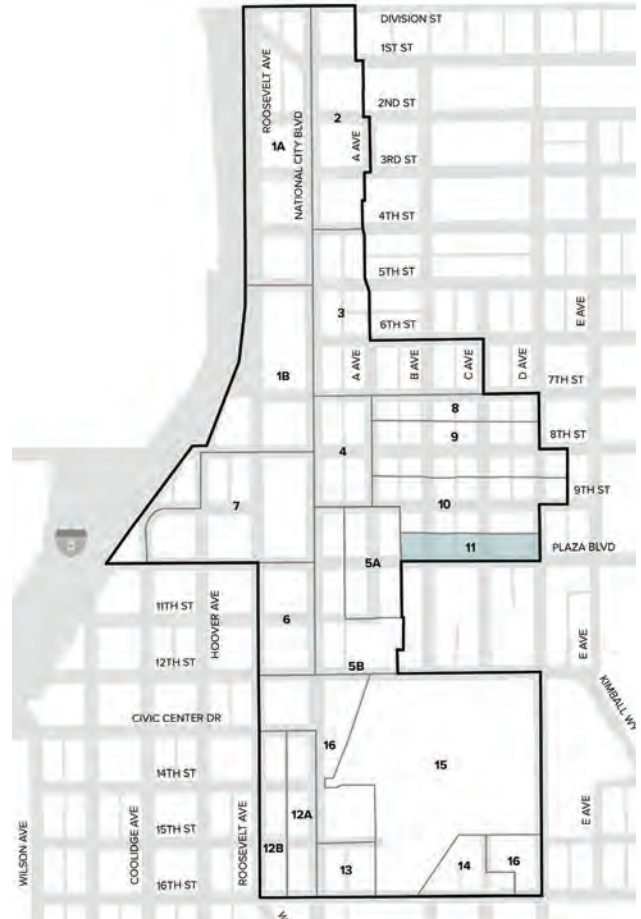

3.5.12 DEVELOPMENT ZONE 12A

3.5.12.1 *Development Intensity*

Floor Area Ratio: 5:1 maximum/2.5:1 minimum

Maximum Height: 90'

Unless otherwise stated, the development standards of the Major Mixed Use Corridor (MXC-2) zone shall apply.

Maximum Number of Units: 232

If maximum number of units is exceeded per zone, a traffic analysis and/or CEQA review may be required. Project would require discretionary review.

3.5.12.2 *General Guidelines:*

This zone fronts on the west side of National City Boulevard, extending from Civic Center Drive to 16th Street and having a depth westward to the alley paralleling National City Boulevard. These sites face the civic buildings across the boulevard and have an unobstructed view to Kimball Park above street level. The police station is immediately to the north of this zone.

The three partial blocks encompassed by this zone enjoy prime frontage on National City Boulevard, but they are beyond the concentrated retail core area envisioned by the Downtown Specific Plan. For that reason, street-level retail is not required on these parcels. Proposed land uses in this zone are multi-family residential, office or hotel. Retail, office, or service uses may be provided at grade, at the discretion of the developer, but these uses should not dilute street-level pedestrian retailing in the heart of the downtown core.

Hotel functions will likely require the combination of these street-facing parcels with additional portions of these blocks extending to Roosevelt Street.

The Downtown Specific Plan calls for this zone to maintain a moderate height and scale and a continuation of the street wall, along National City Boulevard.

3.5.12.3 *Permitted Uses:*

Mid-rise multi-family residential, street-oriented retail, office, or hospitality. Total commercial uses shall not exceed 20 percent of the total development.

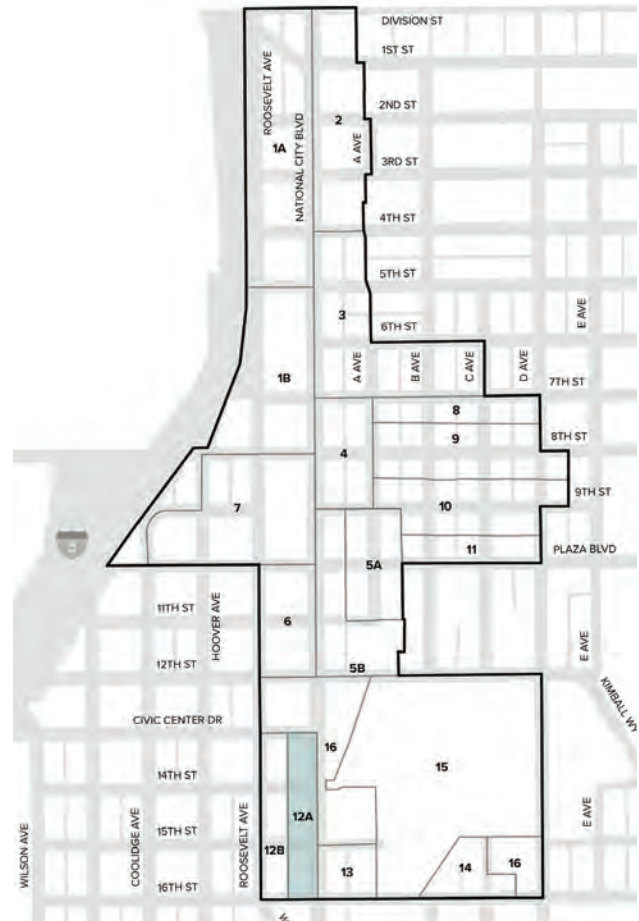

3.5.13 DEVELOPMENT ZONE 12 B

3.5.13.1 Development Intensity

Floor Area Ratio: 4:1 maximum/2:1 minimum

Maximum Height: 65'

Unless otherwise stated, the development standards of the Major Mixed Use Corridor (MXC-2) zone shall apply.

3.5.13.2 General Guidelines:

This zone has frontage along the east side of Roosevelt Avenue from Civic Center Drive to 16th Street and extends one-half block to the east. This zone is adjacent to and west of Development Zone 12A, which fronts on National City Boulevard across from Kimball Park and the library. The police station is to the north and the Westside Specific Plan area is to the west and south. Proposed land uses in this zone are multi-family residential, office, or hotel. Retail, office, or service uses may be provided at grade, but these uses should not dilute street-level pedestrian retailing in the heart of the downtown core.

3.5.13.3 Permitted Uses:

Multi-family residential, street-oriented retail, office, or hospitality. Total commercial uses shall not exceed 20 percent of the total development.

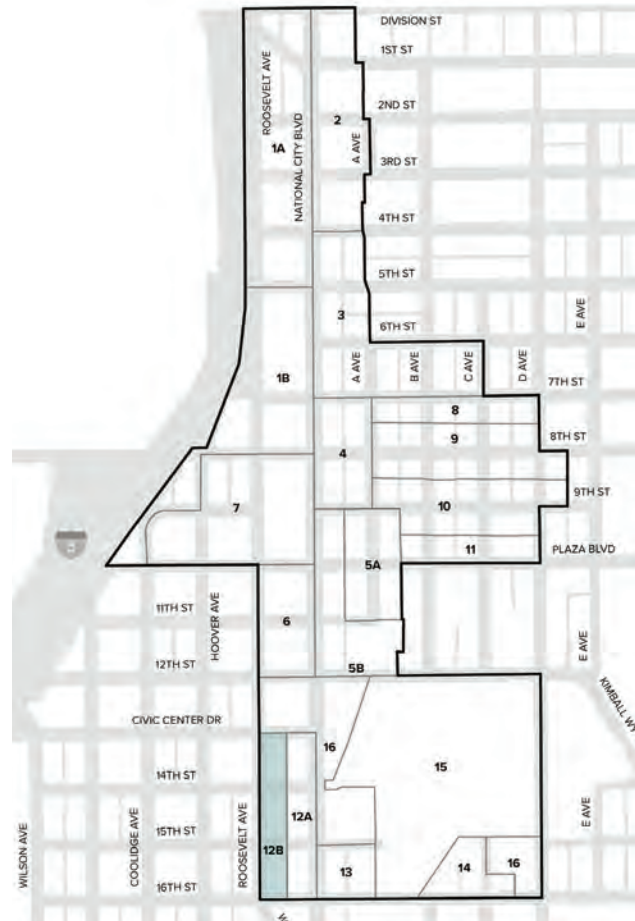

3.5.14 DEVELOPMENT ZONE 13

3.5.14.1 *Development Intensity*

Floor Area Ratio: 4:1 maximum/2:1 minimum

Maximum Height: 75'

Unless otherwise stated, the development standards of the Major Mixed Use Corridor (MXC-2) zone shall apply.

Maximum Number of Units: 52

If maximum number of units is exceeded per zone, a traffic analysis and/or CEQA review may be required. Project would require discretionary review.

3.5.14.2 *Permitted Land Uses:*

Civic uses and mid-rise residential.

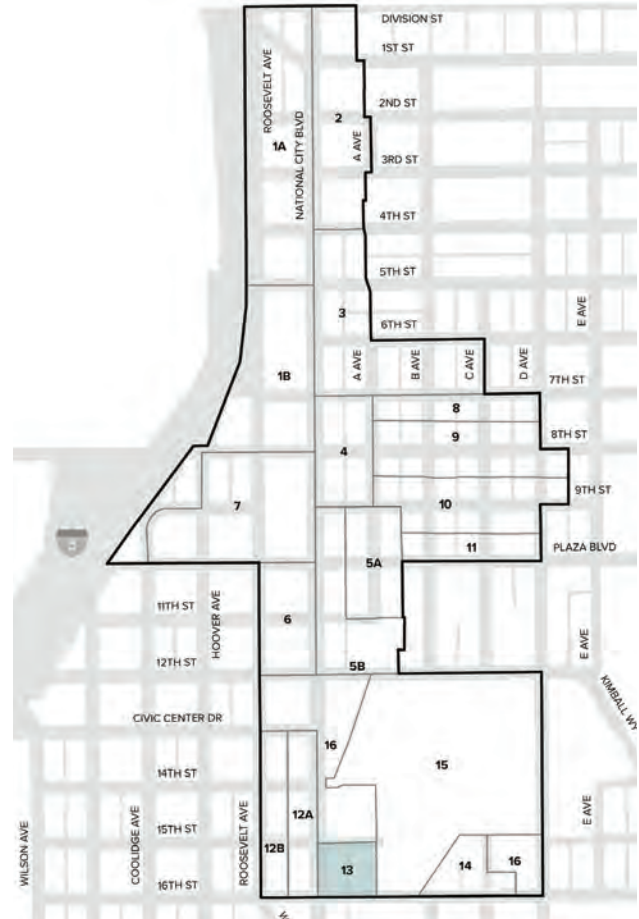

3.5.15 DEVELOPMENT ZONE 14

3.5.15.1 Development Intensity

Floor Area Ratio: 4:1 maximum/2:1 minimum

Maximum Height: 75'

Unless otherwise stated, the development standards of the Major Mixed Use Corridor (MXC-2) zone shall apply.

Maximum Number of Units: 306

If maximum number of units is exceeded per zone, a traffic analysis and/or CEQA review may be required. Project would require discretionary review.

3.5.15.2 Permitted Land Uses:

Mid-rise residential.

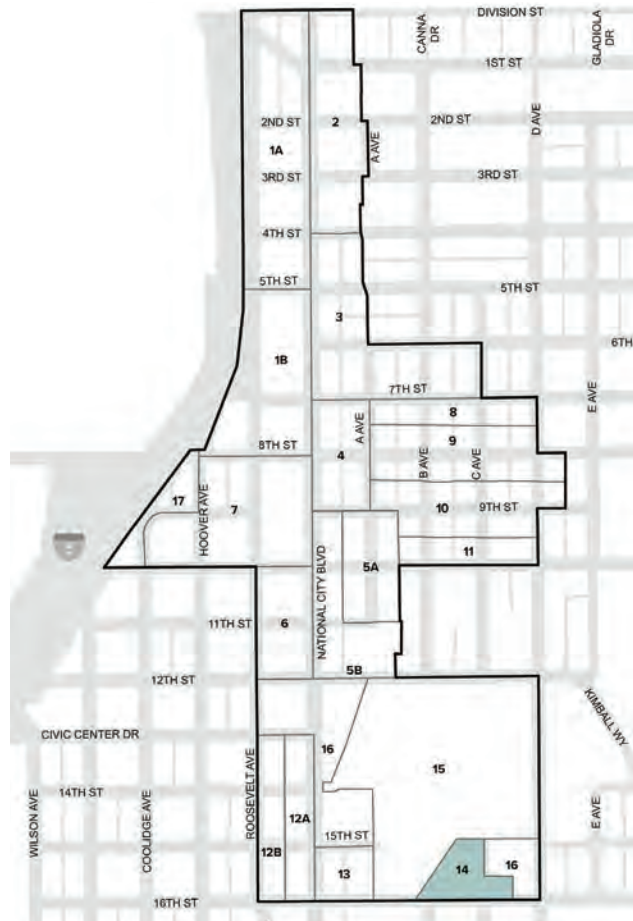

3.5.16 DEVELOPMENT ZONE 15

3.5.16.1 Kimball Park

The land use regulations and development standards of the Open Space Zone shall apply.

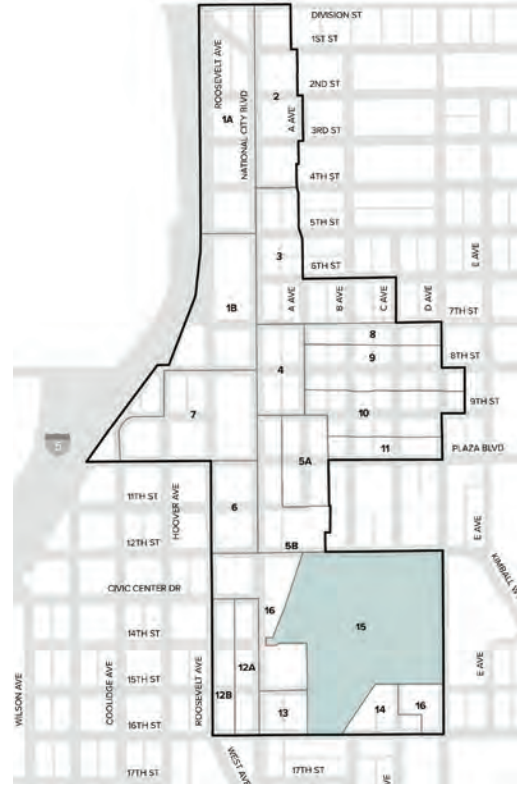

3.5.17 DEVELOPMENT ZONE 16

3.5.17.1 Civic Center

The land use regulations and development standards of the Institutional Zone shall apply.

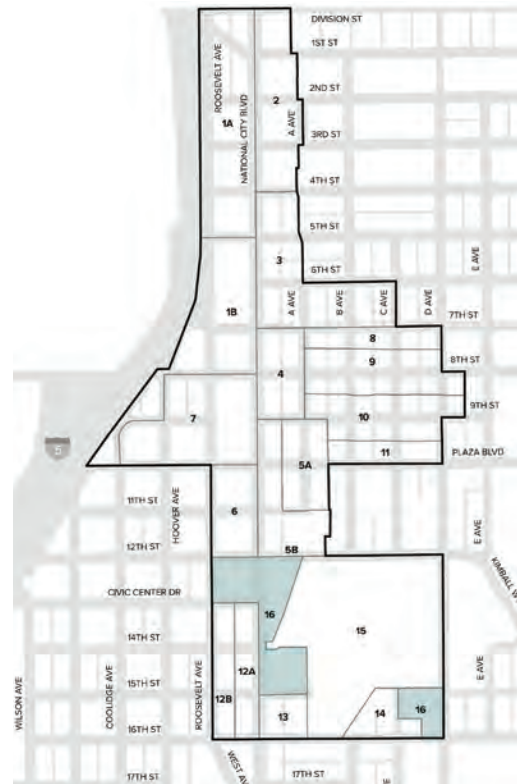



4

CIRCULATION

4.1 INTRODUCTION

This circulation chapter discusses a transportation plan for the movement of people and goods and identifies the general location and extent of existing and proposed major roadways, transportation improvements, transit, pedestrian and bikeway facilities. This chapter addresses the needs of mobility through the development of an integrated, multi-modal circulation network that accommodates both local and regional trips and supports public transit, walking, bicycling, and vehicular traffic.

A goal of the Specific Plan is to revitalize and update the downtown to attract newer businesses and development to the area. The focus on smart growth and smart mobility is an important aspect of this encouragement. It also puts additional focus on if the roads will handle the increase in population that is encouraged by this smart growth. However, since no change is proposed in the overall density, as indicated through no changes in the Floor Area Ratio (FAR), the maximum 5,500 residential units (now adjusted to 5,300 based on past construction since the 2012 update), and the individual development zone restrictions on units allowed have not changed, then the impacts should not exceed the earlier level of service impacts document in the previous EIR for the 2012 General Plan Update.

The circulation plan is strongly correlated with the Land Use Plan for Downtown National City, which supports increased densities and a mix of uses and proposed policies that reduce reliance on personal vehicles by making walking and bicycling more comfortable, safe and convenient. The proposed circulation system benefits people, movement and the environment by providing a wider range of mobility options; making transportation more inclusive and affordable; reducing greenhouse gas emissions and air pollution; increasing activity on the street to support businesses and improve safety, and addressing public health by promoting physical activity.

Downtown National City residents' commuters rely less on driving alone and more on public transit and other means than commuters throughout San Diego County. Table 4-1 shows the modal split of commutes of National City's employed residents compared to San Diego County residents overall.

Table 4-1: National City Commuter Modal Split

Transportation to Work (2015 American Community Survey)	National City Estimate	National City Percentage	San Diego County Estimate	San Diego County Percentage
Total:	26,949	33%	1,504,548	34%
Car, truck, or van:	21,562	27%	1,284,012	29%
Drove alone	17,842	22%	1,143,534	26%
Carpooled:	3,720	5%	140,478	3%
In 2-person carpool	2,952	4%	109,971	2%
In 3-person carpool	637	1%	18,646	0%
In 4-person carpool	84	0%	6,814	0%
In 5- or 6-person carpool	40	0%	2,995	0%
In 7-or-more-person carpool	7	0%	2,052	0%
Public transportation (excluding taxicab):	1,886	2%	45,236	1%
Bus or trolley bus	1,853	2%	38,096	1%
Streetcar or trolley car (carro publico in Puerto Rico)	24	0%	2,755	0%
Subway or elevated	9	0%	374	0%
Railroad	0	0%	3,760	0%
Ferryboat	0	0%	251	0%
Taxicab	0	0%	523	0%
Motorcycle	31	0%	8,736	0%
Bicycle	146	0%	10,027	0%
Walked	761	1%	42,991	1%
Other means	200	0%	10,666	0%
Worked at home	2,363	3%	102,357	2%
	81,066	100%	4,478,822	100%

4.2 EXISTING CONDITIONS

The street system within the Planning Area includes major roadways, which are broken down into three primary functional classifications: arterials, collectors, and local roads. Figure 4-1 identifies the locations of these various roadway typologies within the Planning Area. In addition, a fourth designation that focuses more on qualitative instead of quantitative throughput of roadways are referred to as community corridors (see Figure 4-2). A community corridor is subdivided into Multi-modal streets, “Main Street Type” retail streets, Green Streets and Urban Trail overlays.

4.2.1 ROADWAY CLASSIFICATIONS

Arterial: A major local traffic channel, providing circulation across the city and access to major destination points throughout the region. These are usually comprised of four to six driving lanes, often with synchronized signals to help traffic flow.

Collector: A local conduit that distributes vehicular traffic from neighborhoods or business districts onto arterials and sometimes to other collectors. These may serve as alternate routes to arterials for movement across the city.

Local: A low capacity, low-speed road providing direct access to individual properties within neighborhoods. These roads usually consist of two driving lanes.

Community Corridors: This street type overlay is applied to arterials, collectors, and local streets and are intended to increase the comfort of walking and/or bicycling on these roads through traffic calming measures. Traffic calming measures can include on-street parking, bulb-outs, street trees, medians, and lane or road diets. Pedestrian enhancements, such as wider sidewalks, safe mid-block crossings, improved intersection crossings, street furniture, and street trees can be used to improve walking. Bicycle improvements, such as designated bicycle lanes, multi-use paths, and bike rack facilities can be included. Green streets include urban forestry based street trees, low heat gain surface materials, and various stormwater runoff treatments. These streets also include the incorporation of urban trails, which consist of wider pathways or designated routes for walking that encourages healthy activities and connections to different parts of the downtown area. Figure 4-2 identifies the location of designated community corridors in National City and Figure 4-3 through Figure 4-6 identify sample cross sections for community corridors to illustrate the types of improvements they may contain within the right-of-way.

Figure 4-1: Existing Roadway Classification

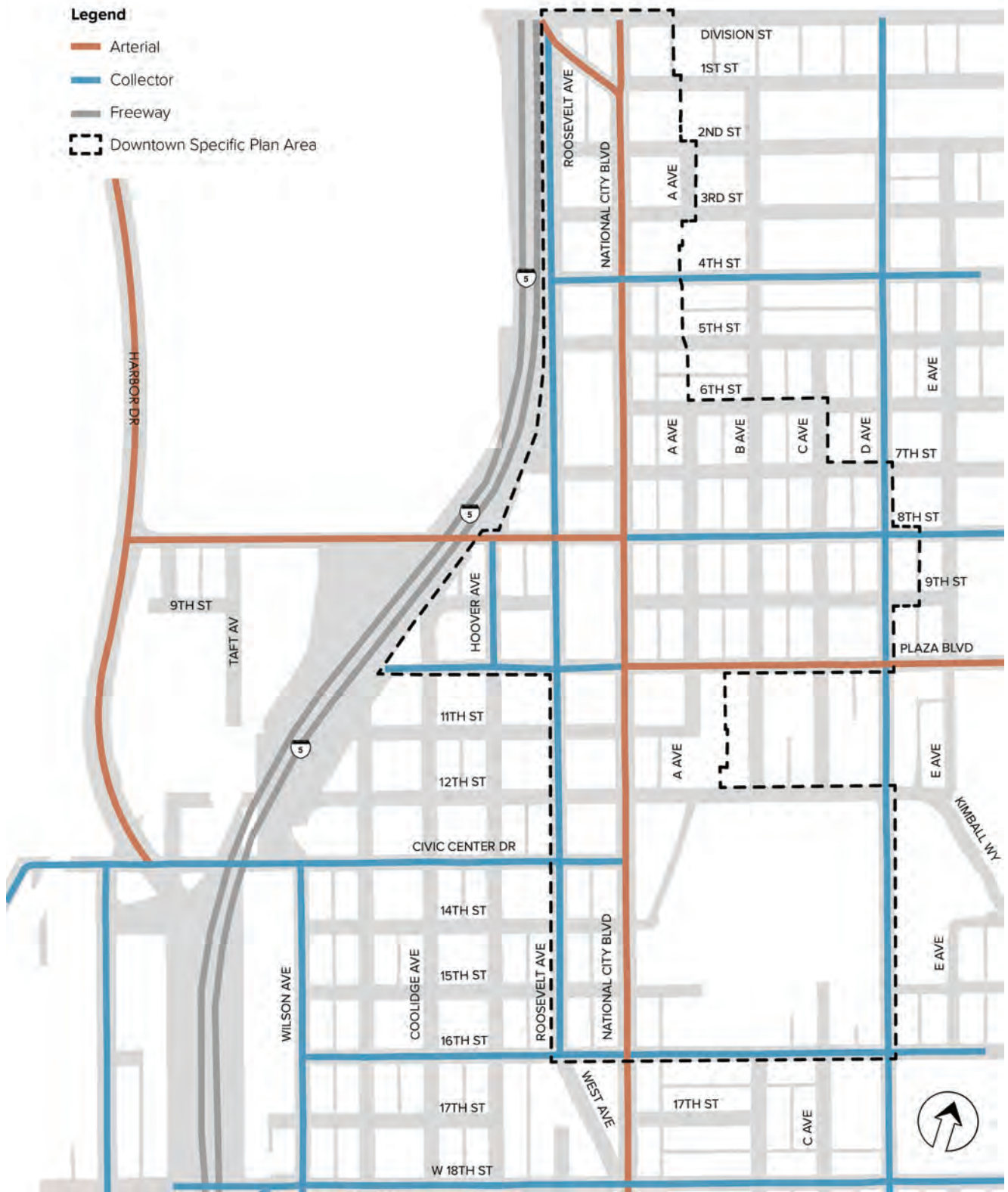

Figure 4-2: Existing and Proposed Community Corridors

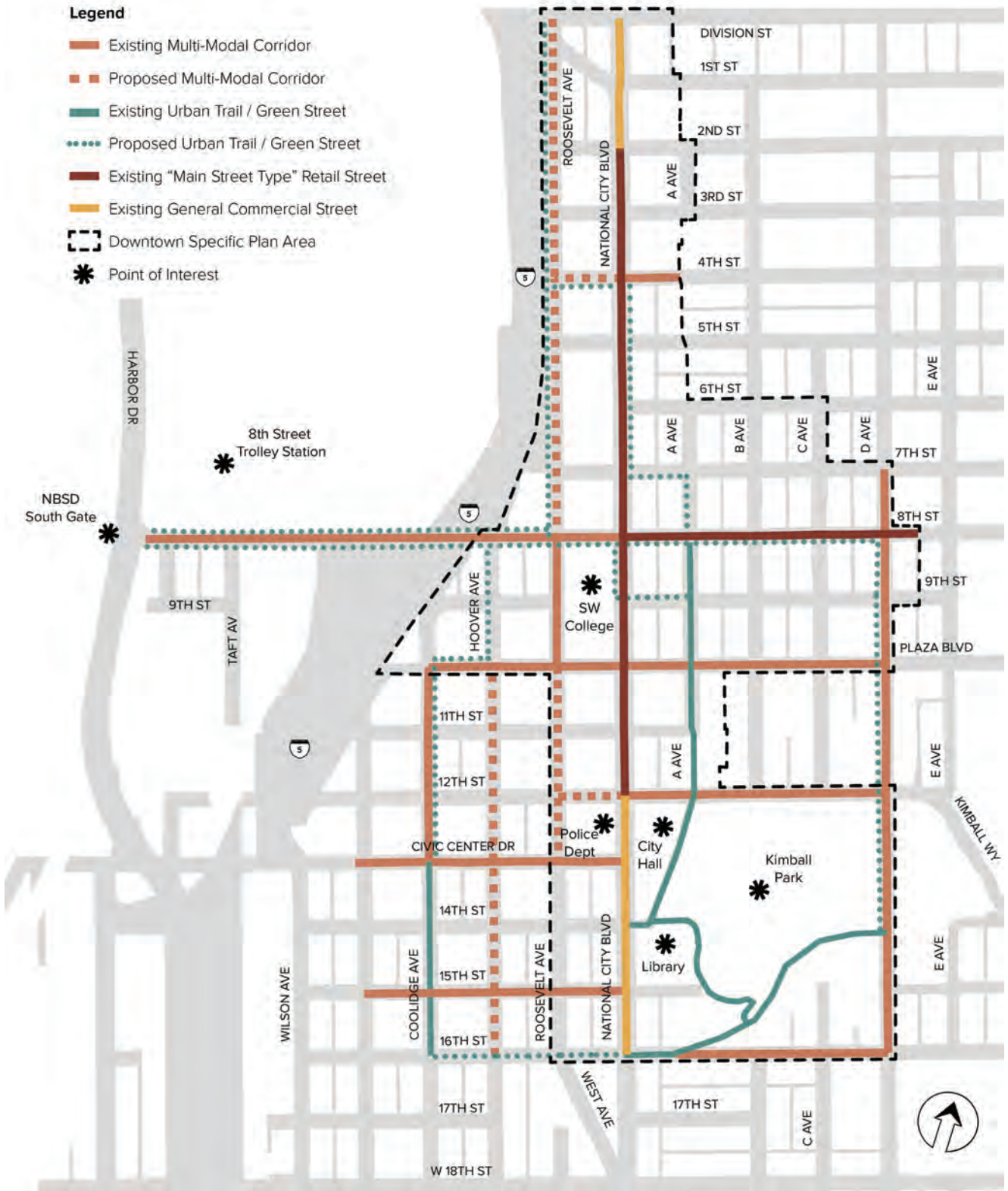

Figure 4-3: Main Street - 8th Street



- ① Banners
- ② Themed street furnishings
- ③ 10 feet wide walkways
- ④ Angled parking
- ⑤ Bulb-outs for shortened pedestrian crossing
- ⑥ Highly visible and short pedestrian crossing distances
- ⑦ Medians for scale and design treatments

Figure 4-4: Main Street National City Boulevard



- ① Lighting
- ② Themed street furnishings
- ③ 10 feet wide walkways
- ④ On-street Parking
- ⑤ Highly visible pedestrian crossing distances
- ⑥ Landscaped median

Figure 4-5: Multi-Modal Corridor

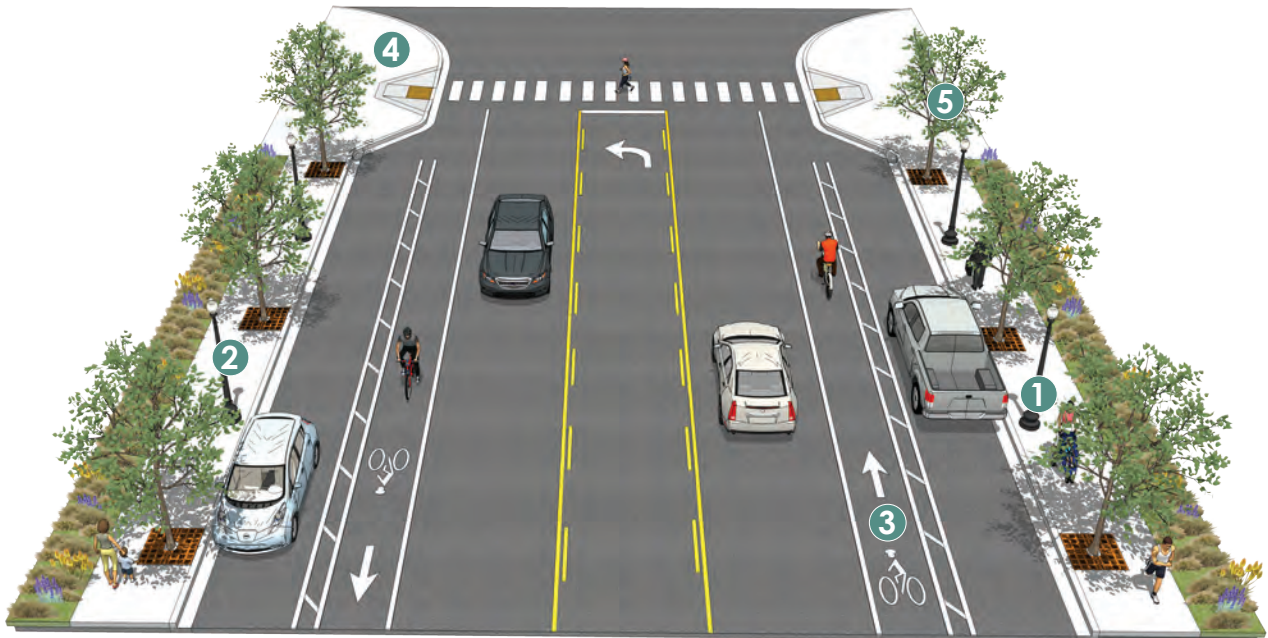

- 1 Widened sidewalks
- 2 Lighting
- 3 Buffered bike lanes on each side
- 4 Bulb-outs
- 5 Street trees for pedestrian safety and comfort

Figure 4-6: Urban Trail/Green Street



- ① Interpretative panels
- ② Urban trail markers and art
- ③ Permeable surfaces for parking
- ④ Large canopy trees for urban forestry, urban heat island reduction, stormwater runoff reduction, traffic calming, and safety
- ⑤ Bioswales

4.2.2 EXISTING CLASSIFICATION OF STREETS IN DOWNTOWN

Division Street is a two-lane collector roadway running on an east-west alignment, which serves as the northern border of the Planning Area. The roadway provides one lane of travel per direction, divided by a two-way left turn lane. It begins at Main Street/National City Boulevard and extends east, past the city limits, where it curves to the south and ends at Plaza Boulevard. The speed limit is not posted, and parking is permitted along both sides of the roadway. Land uses along this roadway throughout the project vicinity are mostly residential with commercial uses near Osborne Street and National City Boulevard. There are no specific improvements planned for this roadway.

1st Street is a local road running on an east/west alignment. It begins at National City Avenue and extends east to Highland Avenue. The roadway provides two lanes of travel per direction, with no striping. Parking is allowed on both sides of the roadway. The roadway, mostly uncontrolled, has a stop sign at D Avenue, and is controlled by a signal at National City Boulevard.

2nd Street is a local road running on an east/west alignment. It begins at Roosevelt Avenue and extends east to Laurel Avenue. The roadway provides two lanes of travel per direction, with no striping. Parking is allowed on both sides of the roadway. The roadway has stop signs at most intersections.

3rd Street is a local road running on an east/west alignment. It begins at Roosevelt Avenue and extends east to Highland Avenue. The roadway provides two lanes of travel per direction, with no striping. Parking is allowed on both sides of the roadway. The roadway is controlled by stop signs at all intersections, including Roosevelt Avenue and National City Boulevard.



Division Street



2nd Street



4th Street

4th Street is a residential collector roadway running on an east/west alignment. It begins at Roosevelt Avenue and extends east past the downtown area to Harbison Avenue. The roadway provides two lanes of travel per direction divided by a double yellow line. Parking is allowed on both sides of the roadway. The roadway is controlled at most intersections. This street has Class 2 bike lanes from Harbison Avenue to National City Boulevard and a Class 3 bike route from National City Boulevard to Roosevelt Avenue.

5th Street is a local road running on an east/west alignment. It begins at Roosevelt Avenue and extends east to Highland Avenue. The roadway provides two lanes of travel per direction, with no striping. Parking is allowed on both sides of the roadway. The roadway is controlled by stop signs at most intersections in the downtown area.

6th Street is a local road running on an east/west alignment. It begins at National City Avenue and extends east to Highland Avenue. The roadway provides two lanes of travel per direction, with no striping. Parking is allowed on both sides of the roadway. The roadway is mostly uncontrolled, but does have a stop sign at National City Boulevard.

7th Street is a local road running on an east/west alignment. It begins at Roosevelt Avenue and extends east to Highland Avenue. Past Roosevelt Avenue, the roadway serves as an on-ramp to the Interstate 5. Parking is allowed on both sides of the roadway. The roadway is mostly uncontrolled, but does have a stop sign at National City Boulevard and Roosevelt Avenue.



8th Street

8th Street is a four-lane collector roadway running on an east-west alignment. The street becomes an arterial roadway from National City Boulevard all the way to Harbor Drive. The roadway provides two lanes of travel per direction, divided by a double yellow line. It begins west of the Interstate 5 at Harbor Drive and extends east to Paradise Valley Road, near the eastern city limits. The speed limit is posted at 35 mph, and parking is permitted along both sides of the roadway. Land uses along this roadway throughout the project vicinity are mostly commercial with some residential uses. Class 2 bike lanes run from Roosevelt Avenue to Harbor Avenue to the west.

9th Street is a local road running on an east/west alignment. It begins at Coolidge Avenue and extends east to E Avenue. Parking is allowed on both sides of the roadway. The roadway is controlled by stop signs at most cross streets.

Plaza Boulevard is a four arterial roadway running on an east-west alignment, which becomes a collector street from National City Boulevard all the way to the western limits of the Planning Area. The roadway provides two lanes of travel per direction, divided by a double yellow line. It begins at Interstate 5 and extends east past the city limits, as Paradise Valley Road. Parking is permitted along both sides of the roadway. Land uses along this roadway throughout the project vicinity are both commercial and residential. There is also a school on the southeast corner of the intersection with F Street.



Plaza Boulevard



Roosevelt Avenue



"A" Avenue



National City Boulevard

11 th Street is a local road running on an east/west alignment. It begins at Harding Avenue and extends east to A Avenue. The roadway provides two lanes of travel per direction, with no striping. Parking is allowed on both sides of the roadway. The roadway provides stop signs at all intersections.

12 th Street is a two-lane local road running on an east/west alignment. It begins in a cul-de-sac west of Harding Avenue and extends east past D Street where it curves to the south and becomes Kimball Avenue. The roadway provides one lane of travel per direction divided by a raised, landscaped median. Parking is allowed on both sides of the roadway. Land uses along this roadway are mostly residential to the north. On the south side of the roadway, east of National City Boulevard, are various community uses, including an amphitheater, the Kimball Senior Center, and the local Community Center. There are Class 2 bike lanes that run from D Avenue to National City Boulevard.

13 th Street is a small residential collector roadway running on an east/west alignment. It begins at Wilson Avenue and extends east past National City Boulevard to the Kimball Park. Parking is allowed on both sides of the roadway.

14th Street is a local road running on an east/west alignment. It begins at Wilson Avenue and extends east past National City Boulevard to the Kimball Park. Parking is allowed on both sides of the roadway. Land uses along this roadway are mostly residential with the Kimball Park to the east. There is no posted speed limit, so the prima facie limit of 25mph would apply.

16th Street is a residential collector roadway running on an east/west alignment. It begins west of Coolidge Avenue and extends past the National City limits. The roadway provides one lane of travel per direction, divided by a double yellow line. Parking is allowed on both sides of the roadway. The roadway is controlled by stop signs at most cross streets. The speed limit is posted at 35 mph, or 25mph in the school zone. The land uses are commercial near National City Boulevard, but mostly residential in the other areas.

Roosevelt Avenue is an industrial collector roadway running on a north/south alignment. It begins at Division Street and extends south to 22nd Street. The roadway provides one lane of travel per direction divided by a dotted yellow line. The land uses along this roadway are mostly commercial, with some scattered residential uses. Parking is permitted along most areas of the roadway, although some locations are restricted to truck parking only. This roadway has Class 2 bike lanes that extend from 4th Street to 8th Street.

National City Boulevard is a four-lane arterial roadway running on a north/south alignment. It begins at Division Street and extends south past the city limits, where it changes names to Broadway and ends at Interstate 805. The roadway provides two lanes of travel per direction divided by a double yellow line. The roadway provides traffic signal at most of the larger intersections, and left turn pockets at most intersections. South of 12th Street, the roadway is divided by a raised, landscaped median. Parking is allowed on both sides of the roadway. Land uses along this roadway are mostly commercial. The speed limit is posted at 35 mph.

“A” Avenue is a local road running on a north/south alignment. It begins at 6th street and extends south to 11 th Street. Land uses along this roadway are mostly residential, with commercial uses near 8th Street. The roadway is also closed

for traffic calming purposes at 9th Street. Parking is allowed on both sides of the roadway. There is no posted speed limit, so the prima facie limit of 25mph would apply.

“B” Avenue is a two-lane local road running on a north/south alignment. In the downtown area, it begins at the Kimball Park and extends north to Division Street. Parking is allowed on both sides of the roadway. The roadway has stop signs at most cross streets. Land uses along this roadway are mostly residential, with commercial uses near 8th Street. There is no posted speed limit, so the prima facie limit of 25mph would apply.

“C” Avenue is a local road running on a north/south alignment. It begins at 5th Street and extends south to the Kimball Park. The roadway provides two lanes of travel per direction, with no striping. Parking is allowed on both sides of the roadway. The roadway is controlled by stop signs at 7th, 8th, 9th, and 12th Streets and Plaza Boulevard.

“E” Avenue is a local road running on a north/south alignment which begins at 8th Street and extends north to 2nd Street. The roadway provides one lane of travel per direction, with no striping. Parking is permitted along both sides of the roadway and the land uses are residential. The roadway is controlled by a stop sign at 8th and 4th Streets and a yield sign at 5th Street. All other intersections are uncontrolled.



4.2.3 PUBLIC TRANSIT CONDITIONS

The Planning Area is served by a regional transit system operated by the San Diego Metropolitan Transit System (MTS). There are 10 bus routes running through National City with a total of 205 bus stops and two transit centers. There are seven bus lines that run through the Planning Area. Additionally, the Planning Area includes one MTS Trolley station, which is located on the Blue Line Trolley running from Old Town and Downtown San Diego to the US-Mexico border. The 8th Street Trolley Station is located near the intersection of 8th Street and Harbor Drive. The downtown is well served by transit, making it a qualified smart growth area as well as a well-served transit area that qualifies for special State of California streamlining and requirements for affordable housing, special tax credits, and infrastructure investments. The existing transit lines and stops are shown on Figure 4-7.

4.2.4 PEDESTRIAN CONDITIONS

Walkability within the Planning Area is serviced by a traditional grid of streets, all with adjacent sidewalks. A constraint to improving walkability in the Planning Area is the difficulty of providing safe, mid-block or intersection crossings between major controlled intersections along the city's major thoroughfares and within commercial districts. The limited number of controlled intersections are helpful for vehicular travel throughput but not as helpful for pedestrian crossings. These problems generally apply to streets where multiple lanes occur, where traffic volume is above 5,000 ADT or where speeds are above 35 mph. Overall, the gridded streets provide for a system whereby traffic is distributed over multiple streets instead of concentrated on a few major ones. This is also beneficial to pedestrians, since multiple lanes are not often needed and volumes of traffic are diluted across many streets. Urban trails proposed in the downtown area are shown on Figure 4-8.

4.2.5 BIKEWAY CONDITIONS

The Planning Area contains two regional bikeways: The Bayshore Bikeway and the Sweetwater River Bikeway. The Bayshore Bikeway is a 26-mile regional bicycle route that encircles the San Diego Bay and passes through the Planning Area along Harbor Drive and Tidelands Avenue, and provides a link to the nearby cities of San Diego, Coronado, Imperial Beach, and Chula Vista. This route also provides an alternative transportation option to many industrial and military job sites.

The Sweetwater River Bikeway is located along the southern border of National City with segments in Chula Vista. It runs parallel with the Sweetwater River Flood Control Channel. It is approximately 1.7 miles long and varies between eight and ten feet in width. It connects to the Bayshore Bikeway at the Sweetwater Channel near the Gordy Shields Bridge.

The Planning Area includes several on-street bike facilities, although many streets are missing them. However, many of these streets are low stress streets, making cycling without a special bike facility possible. The City of National City's Bikeway Master Plan identifies the location of several proposed local bike routes (see Figure 4-9).

Figure 4-7: Existing Transit Routes and Stops



Figure 4-8: Existing and Proposed Urban Trails

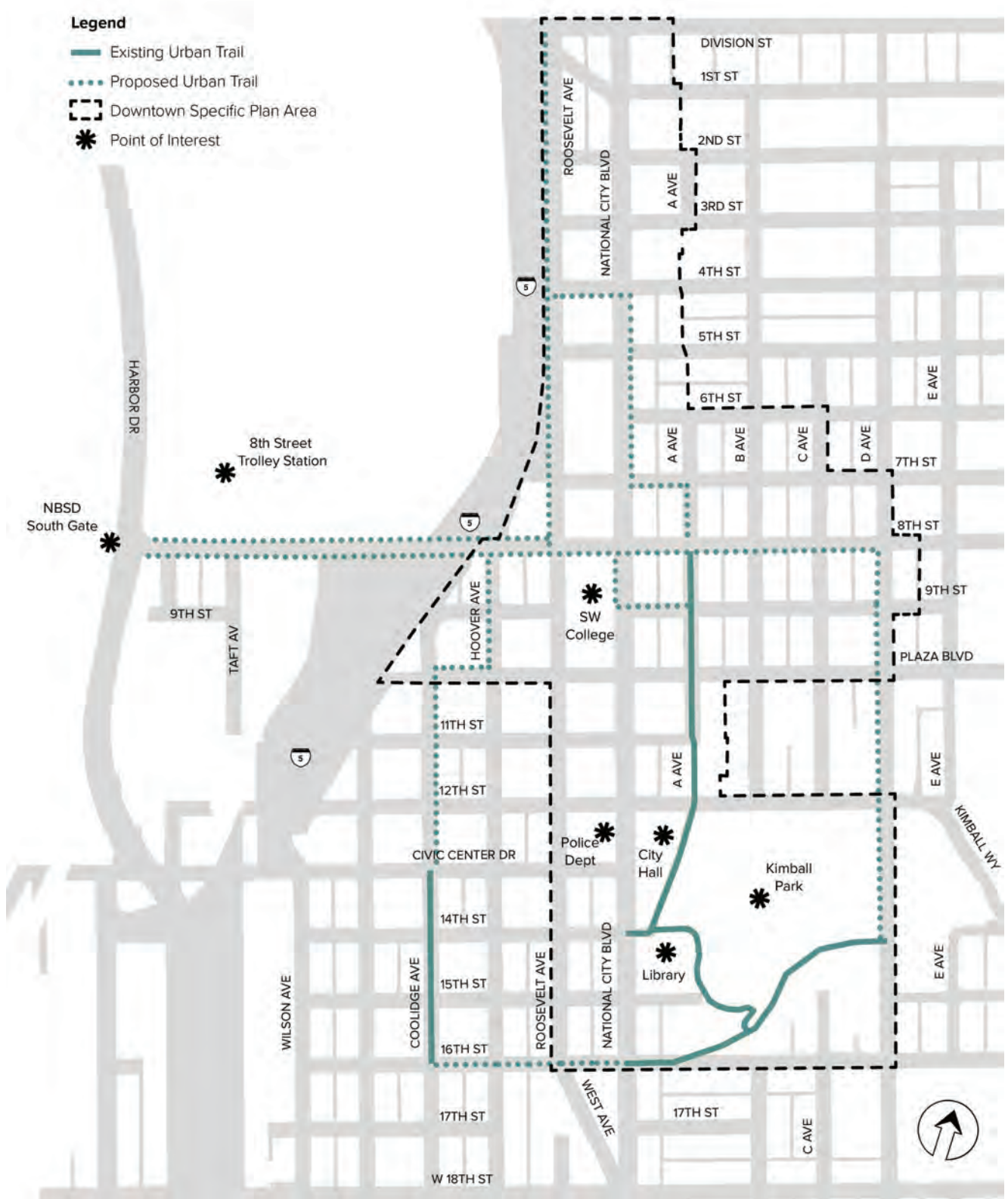
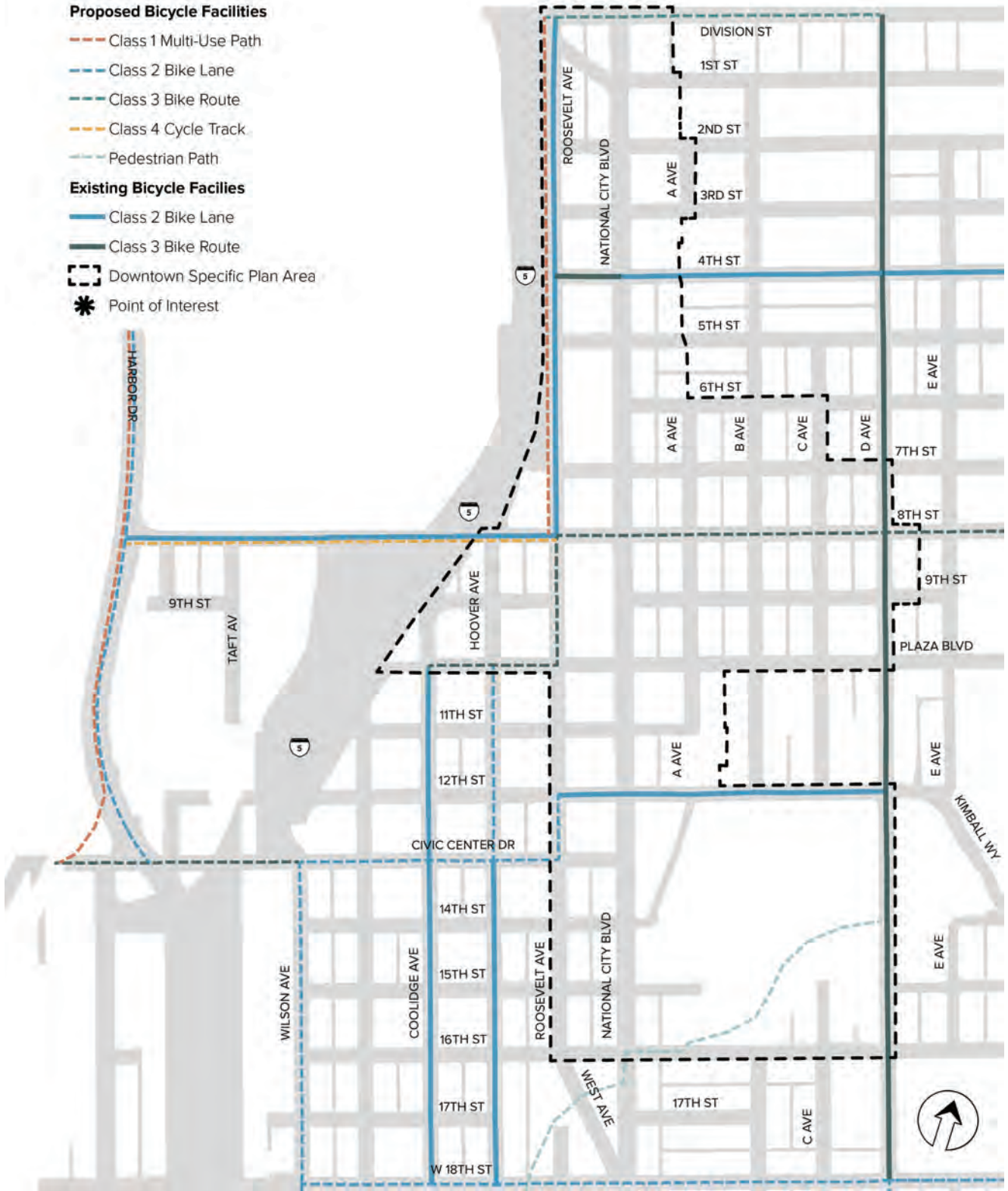

Figure 4-9: Existing and Proposed Bicycle Facilities



4.3 STATE AND FEDERAL ENABLING LEGISLATION AND DIRECTIVES

Several relatively recent statutes support increased bicycling and walking in California. Much of the newest legislation addresses greenhouse gas (GHG) reduction and employs bicycling and walking as means to achieve reduction targets. Other legislation highlights their intrinsic worth and treats bicyclist and walker safety and convenient accommodation as matters of equity. The most relevant legislation concerning bicycle and pedestrian policy, planning, infrastructure and programs are described in the following sections.

4.3.1 STATE LEGISLATION

4.3.1.1 *AB-32 Global Warming Solutions Act*

AB-32 calls for the reduction of greenhouse gas emissions and codifies the 2020 emissions reduction goal. This act also directs the California Air Resources Board to develop specific early actions to reduce greenhouse gases while also preparing a scoping plan to identify how best to reach the 2020 limit.

4.3.1.1 *SB-375 Redesigning Communities to Reduce Greenhouse Gases*

This bill seeks to reduce vehicle miles traveled through land use and planning incentives. Key provisions require the larger regional transportation planning agencies to develop more sophisticated transportation planning models, and to use them for the purpose of creating “preferred growth scenarios” in their regional plans that reduce greenhouse gas emissions. The bill also provides incentives for local governments to incorporate these preferred growth scenarios into the transportation elements of their general land use plans.

4.3.1.2 *AB-1358 Complete Streets Act*

AB-1358 requires the legislative body of a city or county, upon revision of the circulation element of their general plan, to identify how the jurisdiction will provide for the routine accommodation of all users of the roadway including drivers, pedestrians, bicyclists, individuals with disabilities, seniors and public transit users. The bill also directs the OPR to amend guidelines for general plan circulation element development so that the building and operation of local transportation facilities safely and conveniently accommodate everyone, regardless of their travel mode.

4.3.1.3 *AB-1581 Bicycle and Motorcycle Traffic Signal Actuation*

This bill defines a traffic control device as a traffic-actuated signal that displays one or more of its indications in response to the presence of traffic detected by mechanical, visual, electrical or other means. Upon the first placement or replacement of a traffic-actuated signal, the signal would have to be installed and maintained, to the extent feasible and in conformance with professional engineering practices, so as to detect lawful bicycle or motorcycle traffic on the roadway. Caltrans has adopted standards for implementing the legislation.

4.3.1.4 *AB-1371 Passing Distance/Three Feet for Safety Act*

This statute, widely referred to as the “Three Foot Passing Law,” requires drivers to provide at least three feet of clearance when passing bicyclists. If traffic or roadway conditions prevent drivers from giving bicyclists three feet of clearance, they must “slow to a speed that is reasonable and prudent” and wait until they reach a point where passing can occur without endangering the bicyclist. Violations are punishable by a \$35 base fine, but drivers who collide with bicyclists and injure them in violation of the law are subject to a \$220 fine.

4.3.1.5 SB-743 CEQA Reform

Just as important as the aforementioned pieces of legislation that support increases in bicycling and walking infrastructure and accommodation is one that promises to remove a longstanding roadblock to them. That roadblock is vehicular Level of Service (LOS) and the legislation with the potential to remove it is SB-743.

For decades, vehicular congestion has been interpreted as an environmental impact and has often stymied on-street bicycle projects in particular. Projections of degraded Level of Service have, at a minimum, driven up project costs and, at a maximum, precluded projects altogether. SB-743 could completely remove LOS as a measure of vehicle traffic congestion that must be used to analyze environmental impacts under the California Environmental Quality Act (CEQA).

This is extremely important because adequately accommodating bicyclists, particularly in built-out environments, often requires reallocation of right-of-way and the potential for increased vehicular congestion. The reframing of Level of Service as a matter of driver inconvenience, rather than an environmental impact, allows planners to assess the true impacts of transportation projects and will help support bicycling projects that improve mobility for all roadway users.

4.3.1.6 AB-1193 Bikeways

This act amends various code sections, all relating to bikeways in general, specifically by recognizing a fourth class of bicycle facility, cycle tracks. However, the following may be even more significant to future bikeway development:

Existing law requires Caltrans, in cooperation with county and city governments, to establish minimum safety design criteria for the planning and construction of bikeways, and requires the department to establish uniform specifications and symbols regarding bicycle travel and traffic related matters. Existing law also requires all city, county, regional and other local agencies responsible for the devel-

opment or operation of bikeways or roadways to utilize all of those minimum safety design criteria and uniform specifications and symbols.

This bill revised these provisions to require Caltrans to establish minimum safety design criteria for each type of bikeway, and authorizes local agencies to utilize different minimum safety criteria if adopted by resolution at a public meeting.

4.3.1.7 Caltrans' Deputy Directive 64-R1

Deputy Directive 64-R1 is a policy statement affecting Caltrans mobility planning and projects requiring the agency to:

"...provide for the needs of travelers of all ages and abilities in all planning, programming, design, construction, operations, and maintenance activities and products on the State highway system. The Department views all transportation improvements as opportunities to improve safety, access, and mobility for all travelers in California and recognizes bicycle, pedestrian, and transit modes as integral elements of the transportation system." The directive goes on to mention the environmental, health and economic benefits of more Complete Streets."

4.3.2 FEDERAL LEGISLATION

4.3.2.1 Safe Streets Act (S-2004/HR-2468)

This act encourages safer streets through policy adoption at the state and regional levels, mirroring an approach already being used in many local jurisdictions, regional agencies and state governments. The bill calls upon all states and metropolitan planning organizations (MPOs) to adopt Safe Streets policies for federally funded construction and roadway improvement projects within two years.

4.4 GENERAL PLAN GOALS AND POLICIES AFFECTING THE SPECIFIC PLAN

The following goals and policies have been included in this document to set the context for recommendations. These are directly taken from the 2012 General Plan Update.

4.4.1 LAND USE AND CIRCULATION LINKAGES

Policy C-1.1: Allow, encourage, and facilitate transit-oriented development, mixed-use, and infill projects in appropriate locations to reduce vehicular trips, especially near the 8th Street and 24th Street trolley stops, the future South Bay Bus Rapid Transit Station (BRT), and along major transportation corridors such as 8th Street, Highland Avenue, Plaza Boulevard, and 30th Street/Sweetwater Road.

Policy C-1.2: Require new development to provide and enhance connectivity to existing transportation facilities via the provision of key roadway connections, sidewalks, and bicycle facilities.

Policy C-1.3: Require new development and redevelopment to provide good internal circulation facilities that meets the needs of walkers, bicyclists, children, seniors, and persons with disabilities.

Policy C-1.4: Require new development and redevelopment to apply universal design standards.

Policy C-1.5: Work with state, regional, and local transportation entities to improve and expand transportation facilities and services that link residents to important land use destinations such as workplaces, schools, community and recreation areas, and shopping opportunities.

Policy C-1.6: Exact fees on new development and redevelopment sufficient to cover the fair share portion of that development's impacts on the local and regional transportation system, including multi-modal facilities, and/or directly mitigate its impacts to the transportation system through construction of improvements.



Mixed-use project



Bus shelters and trees create inviting streetscapes



Street amenities near shopping opportunities

4.4.2 MOBILITY POLICIES AND GOALS

Revisions in planning law recognize the importance of planning for multiple modes of transportation, which provide for the needs of all users (including pedestrians, bicyclists, mass transit riders, motorists, etc.). (See AB 1358 [2008]; SB 375 [2008].) Revisions in environmental regulations also recognize that the overall effectiveness of the transportation system should be considered. (See California Natural Resources Agency, Final Statement of Reasons for Regulatory Action: Amendments to the State CEQA Guidelines Addressing Analysis and Mitigation of Greenhouse Gas Emissions Pursuant to SB97, December 2009, page 75.)

In some instances, deterioration of vehicular level of service may result in improvements to other forms of transportation, such as walking or bicycling, which may in turn have beneficial effects on air quality, greenhouse gas emissions, energy consumption, and health. Walking and bicycling provide the additional benefits of improving public health and reducing treatment costs for conditions associated with reduced physical activity including obesity, heart disease, lung disease, and diabetes.

Policy C-2.1: Develop and maintain an interconnected, grid- or modified grid-based transportation system that sustains a variety of multi-modal transportation facilities.

Policy C-2.2: Enhance connectivity by eliminating gaps and barriers in roadway, bikeway, and pedestrian networks.

Policy C-2.3: Strive to attain an automobile Level of Service (LOS) of D or better (or an equivalent standard under another analytical methodology). An automobile LOS of E or F may be acceptable under the following circumstances:

- 1) improvements necessary to attain a automobile LOS of D or better would decrease the effectiveness of the nonautomotive components of the multi-modal circulation system (i.e. pedestrians, bicyclists, mass/public transit, etc.), or 2) improvements necessary to increase the effectiveness of



Intersection markings provide additional safety & comfort



Mid-block crossings eliminate roadway barriers



Multimodal transportation options are beneficial

the non-automotive components of the multimodal transportation system result in a decrease in automobile LOS.

Policy C-2.4: Work with Caltrans, SANDAG, MTS, and other responsible agencies to identify, plan, and implement needed transportation improvements.

Policy C-2.5: Encourage traffic circulation improvements that minimize land acquisition and major construction, such as, but not limited to, enhanced road markings, synchronized traffic signals, Intelligent Transportation System (ITS) network management and more left turn restrictions.

Policy C-2.6: Enhance the quality of life in the city's neighborhoods and minimize impacts on schools, hospitals, convalescent homes and other sensitive facilities through the implementation of traffic calming measures in these areas to reduce vehicle speeds and discourage cut-through traffic.

Policy C-2.7: Improve circulation for specific areas of the city such as at the Harbor Drive/Tidelands Avenue/Civic Center Drive Intersection and the area west of National City Boulevard, south of 22nd Street and north of Mile of Cars Way.

Policy C-2.8: Implement road diets, where appropriate, as a means to improve safety, increase efficiency of pick-up and drop-off operations at schools, and provide greater separation between pedestrians and vehicles.

Policy C-2.9: Maintain a roadway circulation system with multiple alternative routes, to the extent feasible, to ensure mobility in the event of emergencies, and to minimize the need for capacity increases on particular streets. As needed, use signage to direct traffic to alternative routes during peak periods.

Policy C-2.10: Consider traffic circles or roundabouts as an intersection traffic control option, where feasible and appropriate.

Policy C-2.11: Maintain safety throughout the circulation system by taking opportunities to introduce a safe design speed of any new roadways or during improvements to existing roads or intersections.

Policy C-2.12: Reduce crash risk on arterial streets by consolidating and minimizing driveways whenever possible.

4.4.3 TRANSPORTATION DEMAND MANAGEMENT POLICIES AND GOALS

Reducing vehicular trips, especially at peak commuting times, can be accomplished through: improvements to pedestrian circulation, bike and transit systems; increased use of carpooling; and accommodations made by employers to allow for flexible work schedules, including work from home provisions. Trip reduction, by whichever means, translates into less traffic congestion, fewer greenhouse gas, emissions and improved regional and local air quality.

Policy C-4.1: Encourage businesses to provide flexible work schedules for employees.

Policy C-4.2: Encourage employers to offer shared commute programs and/or incentives for employees to use transit.

Policy C-4.3: Require new uses to provide adequate bicycle parking and support facilities.

Policy C-4.4: Encourage carpooling and other shared commute programs.

Policy C-4.5: Encourage the use of alternative transportation modes.

Policy C-4.6: Prioritize attention to transportation issues around schools to reduce school-related vehicle trips.

Policy C-4.7: Seek opportunities to reduce vehicle trips before requiring physical roadway improvements.

4.4.4 PUBLIC TRANSIT POLICIES AND GOALS

Expanding use of the transit system will help the community meet numerous goals and objectives set forth in the General Plan including, increasing mobility, preserving and enhancing neighborhood character, improving air quality, reducing storm water runoff, reducing paved surfaces, and fostering compact development and a more walkable city.

Policy C-7.1: Encourage responsible agencies to provide a well-designed transit system that meets the needs of the community, commerce, and visitors.

Policy C-7.2: Improve bus stop and shelter facilities to increase the comfort of users.

Policy C-7.3: Provide multi-modal support facilities near and to/from transit stops for bicyclists and pedestrians, including children and youth, the seniors, and persons with disabilities.

Policy C-7.4: Encourage transit providers to post route maps and pick up/drop off times at each stop.

Policy C-7.5: Work with transit providers to maintain and enhance services within the city that are timely, cost-effective, and responsive to growth and redevelopment.

Policy C-7.6: Encourage responsible agencies and affected businesses to provide shuttle service between transit stations to major activity centers.

Policy C-7.7: Work with responsible agencies to provide convenient bus stop locations.



Santa Monica bus-only lanes



San Diego MTS bike racks



OCTA transit day pass



Wide, enhanced pedestrian walkway with safety buffer



Enhanced midblock crossing near school



Attractive pedestrian improvements at intersection

4.4.5 PEDESTRIAN CIRCULATION POLICIES AND GOALS

Improving the pedestrian system through enhancements to walkability – more attractive streetscapes, continuous, well-paved sidewalks, proximity of destinations, adequate lighting, safe street crossings, etc., is found to encourage pedestrian activity within the community. An increased reliance on walking and decreased dependence on vehicular transport poses both health and environmental benefits.

Policy C-8.1: Provide connectivity of wide, well-lit walking environments with safety buffers between pedestrians and vehicular traffic, when feasible.

Policy C-8.2: Require new development and re-development to incorporate pedestrian-oriented street designs that provide a pleasant environment for walking.

Policy C-8.3: Identify and implement necessary pedestrian improvements with special emphasis on providing safe access to schools, parks, community and recreation centers shopping districts, and other appropriate facilities.

Policy C-8.4: Promote walking as the primary travel mode to schools.

Policy C-8.5: Improve pedestrian safety at intersections and mid-block crossings.

Policy C-8.6: Reduce architectural barriers that restrict full movement and access by less mobile segments of the population consistent with the Americans with Disabilities Act.

Policy C-8.7: Apply universal design standards to the pedestrian system.

Policy C-8.8: Provide a continuous pedestrian network within and between neighborhoods to facilitate pedestrian travel free from major impediments and obstacles.

4.4.6 BIKEWAY POLICIES AND GOALS

Bicycling provides a very viable alternative to most in-town trips that are typically taken by car, if the necessary infrastructure to provide for cyclist safety is in place. Bicycling offers many benefits to both the community and the individual cyclist. Bicycling is a non-polluting and sustainable form of transportation that with greater use can help reduce greenhouse gas emissions and the city's carbon footprint. Also, it serves as a form of physical activity, resulting in health benefits for the cyclist.

Policy C-9.1: Expand and improve the bikeway system and facilities by establishing bike lanes, separated paths, and bicycle storage facilities at major destinations.

Policy C-9.2: Require new development and redevelopment to provide safe, secure bicycle parking facilities.

Policy C-9.3: Require new development and redevelopment to provide connections to existing and proposed bicycle routes, where appropriate.

Policy C-9.4: Encourage existing businesses and new development or redevelopment projects to promote bicycling and provide bike rack facilities, personal lockers, and shower rooms.

Policy C-9.5: Encourage bicycling through education and promotion programs in conjunction with the local school districts.

Policy C-9.6: Keep abreast of bicycle facility innovations in other cities and regions, and seek to incorporate these into the bicycle network.



Separated bicycle facilities



Green conflict striping increase comfort and safety



Secure bicycle parking in commercial zone

4.5 FUTURE TRANSPORTATION IMPROVEMENTS

National City, through both its Capital Improvement Program and the previous Specific Plan and General Plan dated 2012, have identified a number of projects that will improve local roadways, walkability, pedestrian safety, and streetscapes within the community (See Figure 4-10). Some projects are planned to be funded by projects with associated transit facilities, or are associated with bikeways and regional circulation projects funded by SANDAG (Transnet) and Caltrans. Some of the projects that can be found either in or nearby the downtown area include:

4.5.1 PHYSICAL IMPROVEMENTS IMPLEMENTED SINCE THE PREVIOUSLY ADOPTED PLAN

This section looks at specific physical improvements that occurred since the traffic study was completed based on the adopted Specific Plan.

4.5.1.1 *National City Boulevard*

Since the 2012 adopted plan, National City Boulevard was physically altered with the addition of raised, landscaped medians. There were no changes to the number of traffic lanes, so the traffic flow was not affected. The medians improved the aesthetics of the area, but did not negatively affect the traffic circulation patterns. While some left turns for minor side streets were prohibited, they were limited to low volume streets with low volume turning movements. All of the traffic from the closed medians were diverted to intersections to the north or the south.

4.5.1.2 *8th Street*

Since the 2012 adopted plan, the 8th Street Corridor, from National City Boulevard to Highland, was modified from a 4-lane roadway to a two-lane roadway with left turn lanes and raised medians. Some of the excess roadway was used to create angled parking where parallel parking existed before. Bulb-outs were also added in order to reduce the crossing distances for pedestrians. Overall, the traffic calming project has lowered the speed of most vehicles, resulting in a minor amount of diversion of through traffic from 8th to Plaza. Class 2 bike lanes were added from Roosevelt Avenue to Harbor Drive.

4.5.1.3 *“A” Avenue and Civic Center*

The previous plan indicated the need to provide an enhanced pedestrian crossings at A Avenue at Civic Center. Since these streets do not cross, it is assumed that the crossing was meant to be at A Avenue and National City Boulevard at 14th Street. This crossing has been constructed.

4.5.1.4 *Plaza Boulevard from I-5 to A Avenue*

Traffic calming measures and enhanced pedestrian crossings were implemented along Plaza Boulevard from Interstate 5 to A Avenue. All-way stop control and a pocket park were added at the intersection of Plaza Boulevard and Hoover Avenue.

Figure 4-10: Circulation Improvements

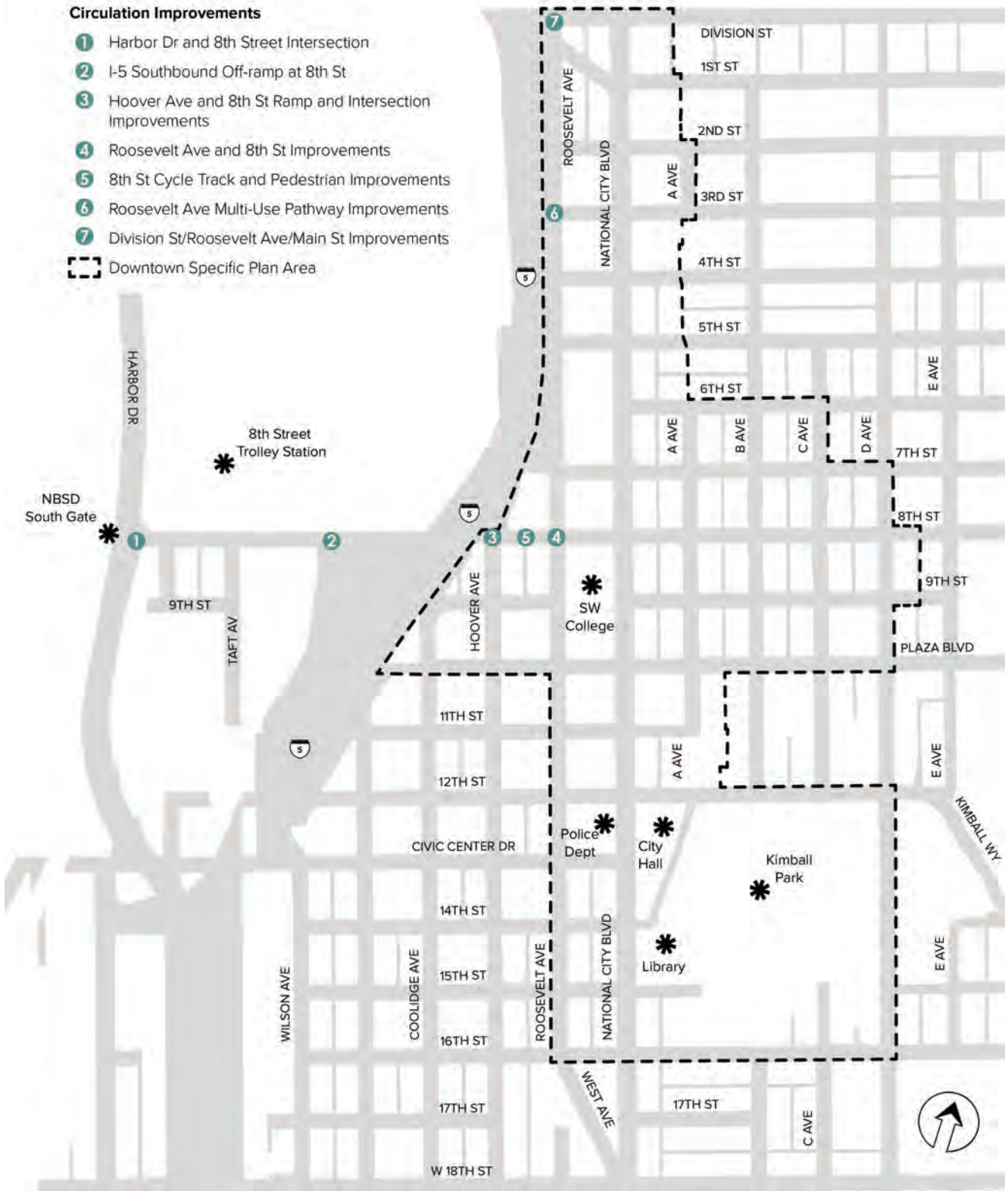

4.5.2 PHYSICAL IMPROVEMENTS ASSUMED IN THE PREVIOUS PLAN NO LONGER RECOMMENDED IN THE UPDATE

This section looks at those previously proposed improvements that are either no longer needed or not supported by this update.

4.5.2.1 7th Street

The previous plan had recommended that 7th Street between National City Boulevard and D Avenue be widened to add a three-lane cross-section. This would have allowed for the existing two-lane roadway to be divided by a two-way left-turn lane, providing easier access for left-turns and improving the roadway operations.

4.5.2.2 8th Street and “A” Avenue

The previous plan had recommended that A Avenue be modified as a full signalized intersection. With the road diet that changed from four lanes to three lanes (one lane each direction with left turn pockets), this signalization is no longer warranted. The pedestrian crossings are considerably safer based on the shorter crossing difference and with the lower speed and vehicular volumes.

4.5.3 PHYSICAL IMPROVEMENTS RECOMMENDED IN THIS UPDATE, NOT IN THE PREVIOUS PLAN OR MODIFIED IN SOME MANNER

New circulation improvements suggested in this update that were not in the previous updated include the following:

4.5.3.1 Harbor Drive and 8th Street Intersection (Project #1)

Currently, pedestrians and cyclists are not allowed to enter Naval Base San Diego using gate 9, which discourages from using the nearby 8th Street trolley station. The proposed project would create such connections, improving access to the base, including public transit users.

4.5.3.2 Interstate 5 Southbound Off-ramp at 8th Street (Project #2)

The proposed project would also consider improvements to the intersection of the Interstate 5 southbound off-ramp and 8th Street. Caltrans has previously indicated that the current configuration of this off-ramp is not beneficial to cyclists and pedestrians using 8th Street. A signalized intersection is warranted and the elimination of the high speed free right turn should be part of this project. Caltrans would need to take the lead on this project.

4.5.3.3 Hoover Avenue and 8th Street Intersection (Project #3)

Hoover Avenue is envisioned as a signalized intersection with direct access to the Interstate 5 northbound on-ramp. Currently, a raised median restricts access to northbound Interstate 5. With future development, south of 8th Street and west of National City Boulevard planned for in the Specific Plan, this direct connection would serve to lower traffic on Roosevelt Avenue, National City Boulevard, and on the eastern portions of 8th Street.

4.5.3.4 Roosevelt Avenue and 8th Street Improvements (Project #4)

The proposed project improvements to the intersection of Roosevelt Avenue and 8th Street are focused on accommodating the proposed cycle tracks and multi-use pathway transitions and to provide for a safe crossing of these bike and pedestrian facilities at this intersection. Curb extensions and enhanced crosswalks for both bike and pedestrian crossings would be included. Areas to the south of 8th Street on Roosevelt Avenue would transition into angled and parallel parking with wrap around bulb-outs at the intersection protecting and defining these parking areas.

4.5.3.5 8th Street Improvements (Project #5)

Although portions of the proposed improvements are outside of the Planning Area, their proximity to the boundary makes them relevant to this study. A one-way Class 4 cycle track is proposed on each side of 8th, in addition to the presence of the existing pedestrian walkway. The southbound off-ramp would be modified to become a standard intersection with standard pedestrian crossings. This would eliminate the high speed right turns from Interstate 5 onto 8th Street. The proposed improvements would proceed all the way down to the trolley station as well as the back gate to Naval Base San Diego at Harbor Drive. This pathway would then connect into the constructed Bayshore Bikeway.

4.5.3.6 Roosevelt Improvements (Project #6)

Roosevelt Avenue is envisioned as a major multi-modal street, with an urban trail/green street overlay. This includes the addition of a 2-way Class 1 multi-use path that would be available to pedestrians, as well as shuttle riders using the proposed neighborhood electric vehicle on both the roadway and the pathway. Additional stop signs would be added at locations where shuttle pickups are envisioned. Parking would be increased along this roadway and the prohibition of truck parking would be considered as well. The parking spaces would be defined by the use of tree bulb-outs that would prevent trucks from parking in sub-standard spaces. The prohibition on truck parking along Roosevelt Avenue could be phased, allowing some segments to remain on an interim basis to allow the adjacent hotels that do cater to truck drivers, some ability to modify their off-site parking for trucks or make other arrangements for shuttles or other approved truck parking. In the future, with the implementation of the Roosevelt Avenue and 8th Avenue bike and shuttle improvements, drivers could be picked up and brought to the hotels from other remote areas where the truck parking would not be as problematic or in competition with vehicle parking, the proposed multi-use path, and the proposed shuttle NEV system.

4.5.3.7 Division Street/Main Street and Roosevelt Avenue Improvements (Project #7)

Image 5 shows the reconfiguration of Roosevelt Avenue where National City Boulevard meets Main Street and where Division Street comes in from the north. This intersection is currently difficult to cross from the south and north. A full intersection is needed and the geometry of the roadway will need to be adjusted to provide more favorable design for signalization and safe traffic lane alignments.

Figure 4-11: Proposed Roadway Improvements



Figure 4-12: Potential Roadway Improvements on 8th Street

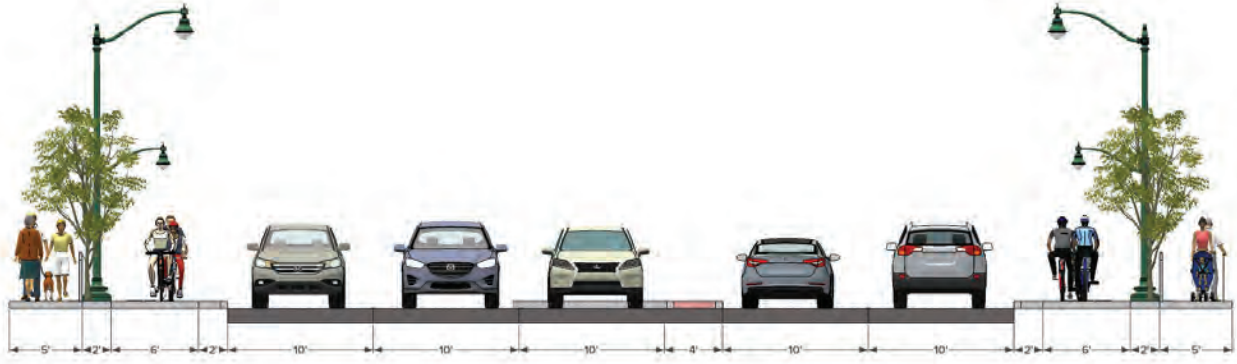
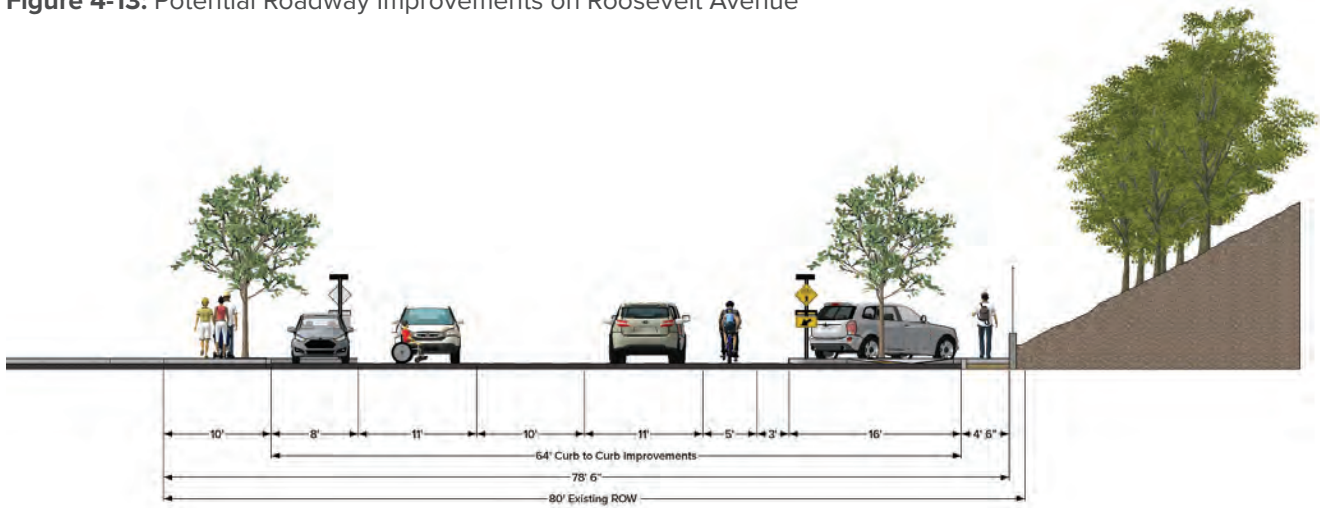

Figure 4-13: Potential Roadway Improvements on Roosevelt Avenue



4.5.4 DETAILED DESCRIPTIONS OF MAJOR TRANSPORTATION IMPROVEMENTS

4.5.4.1 *The Roosevelt and 8th Street Multi-modal Corridor and Shuttle Route*

National City is ideally situated to provide connections from downtown to local transit stops (8th Street and 24th Street trolley stations) and to major employers found adjacent to the city. Naval Base San Diego is a major employer in the area and the potential for Naval Enlisted 4 and above including officers (as either bachelors or married with families) are a potential market for housing development in the downtown area. In addition, if the connections between the military base are improved, better access and use of National City retail outlets, services, and hotels would be likely.

Roosevelt is currently an underutilized site that has had problems with the excess capacity and parking being used up by truck parking and overnight staging. Some of this is related to the high visibility of this roadway edge from Interstate 5, motivating some companies to display their adds and company logos next to the freeway. Another factor is Port truck traffic that often has to wait overnight to utilize the port trucking facilities in the early morning hours. Additionally, free and convenient parking on Roosevelt attracts driver to park there. In any case, residents have complained about a number of illicit activities, trash, and the domination of parking spaces by trucks. It is a recommendation of this plan to restrict overnight or daily truck parking in this location. Instead, the space can provide an improved edge that will improve the positive perception of the City of National City, provide a space for a multi-use pathway (bikes, peds and shuttle) and add needed on-street parking and street trees in this area of the downtown.

Figure 4-11 shows the overall two corridors as well as a series of three-dimensional models showing how this corridor can be improved. Image #1 shows the intersection of Harbor Drive and 8th Street (Project #1). Improved connections to gate 9 are possible, in cooperation with the Navy.

Image 2 shows the possible improvements to the Hoover and 8th Street intersection (project #3) that would include a full signalized intersection, providing northbound Hoover with access to the freeway on-ramp. Because of the proposed one-way cycle tracks on each side of 8th (Project #5), no right turn on reds would have to be instituted, which is difficult without a full intersection. The improvements for Project #3 would help provide an alternative roadway grid to the freeway for future development south of 8th Street and west of National City Boulevard. This would serve to reduce the traffic volume on these streets that are already providing a below standard level of service. Image 3 shows how the Roosevelt (south of 8th Street) could be improved with better pedestrian facilities, crossings and angle parking (Project #4). An improved streetscape plan would also encourage walking and biking more, making make this street more important.

The major change to 8th Street, however, would be the addition of the one-way cycle tracks and buffers between the cycle tracks and the walking environment (Project #5). This is all accomplished through the removal of the on-street bike lane, a slight reduction to lane widths, and the creation of a raised bike lane or cycle track. Pedestrians would be provided an additional buffer between vehicles and themselves through the creation of the cycle track. Existing street trees and lighting would remain in their current locations. The use of tree grates remains necessary for walking surfaces to meet minimum ADA standards. Figure 4-12 shows a cross section on how this plan would lay out on the street.

The plan for the Roosevelt corridor would be different than the 8th Street Corridor (Project #6). The plan suggests two options for the reconfiguration of Roosevelt Street. Option A (see Figure 4-14) shows how the street right of way can be reconfigured to accept a Class 1 Multi-use pathway. This option will not allow for angled parking, but will accommodate parallel parking on each side

of the street. The use of planted bulb-outs would help to prevent truck parking and would provide an urban street tree solution that can address urban heat island reduction, stormwater runoff and safety and traffic calming aspects for the street.

Option B would accommodate more parking by providing angled parking, but would not accommodate bikes in a very beneficial way (see Figure 4-15). A bike lane could occur along the west side, but a shared lane with sharrow would have to occur on the other side of the street. This would reduce the potential for funding or the improvements by way of active transportation related funding grants. However, it would increase on-street parking. Please refer to Chapter 5 on parking to discuss more of the parking specifics of this proposal. Image 4 shows the reconfiguration of Roosevelt where National City Boulevard meets Main Street and where Division Street comes in from the north (Project 7).

Images 5-8 show other components of the improvements along Roosevelt. It should be noted that the project will require both undergrounding of the utility lines (which could occur under the trail to provide for maintenance access), and will require grading and retaining wall construction to move into the existing Caltrans slopes. Image #9 shows how a new gateway monument could be added at the north end of Roosevelt. The first step in this project would be the verification of City and Caltrans right-of-ways and the technical feasibility of fitting these proposed elements of the plan.

Image 9 shows how the project will need to have a turnaround and a transit stop to support the proposed electric shuttle system. A creek exists in the area as well as a southbound I-5 on-ramp that would require a safe and controlled pedestrian crossing point to those using the proposed shuttle wishing access to gate 32 at Yama Street. This would need to be coordinated with the Navy and Caltrans.

Interstate 5 southbound off-ramp and 8th Street reconfigurations (Project #2) are shown in more detail on Image 10. Hoover and Interstate 5 on-ramp improvements (Project #3) are also shown in more detail on Image 11. Finally, the Main Street, Division Street and Roosevelt Avenue changes (Project #7) have been shown in more detail on Image 12.



Image 1



Image 2



Image 3



Image 4



Image 7



Image 5



Image 8



Image 6



Image 9

Figure 4-14: Option A - Parallel Parking and Multi-Use Path

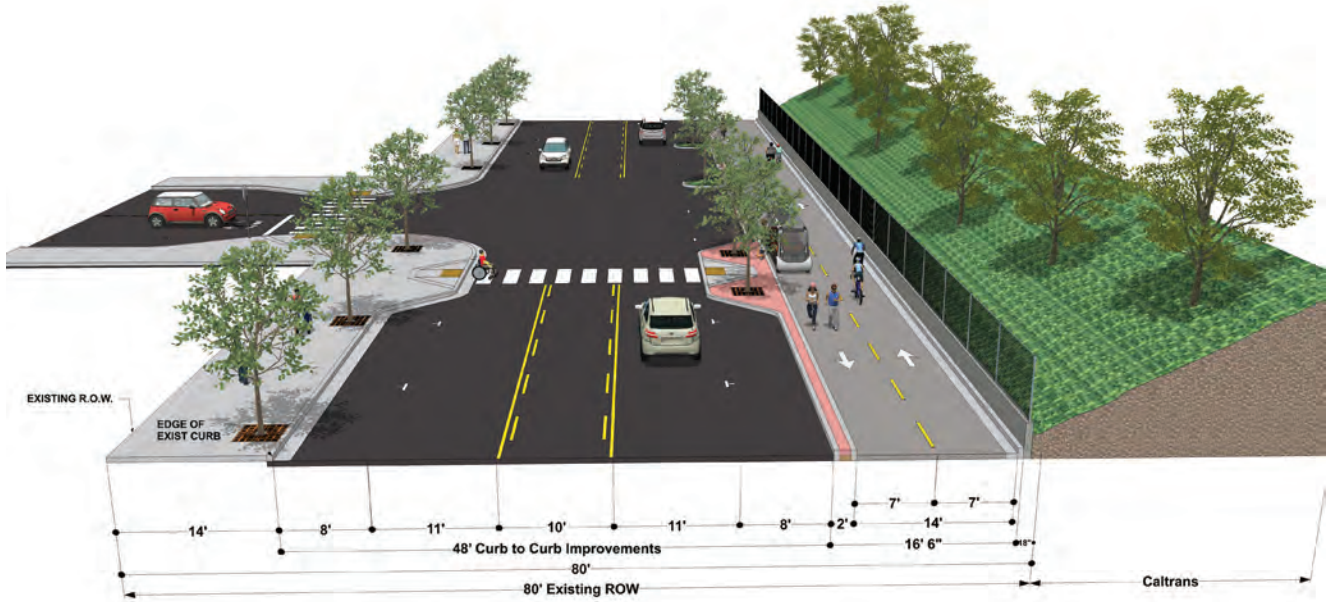

Figure 4-15: Option B - Angled Parking

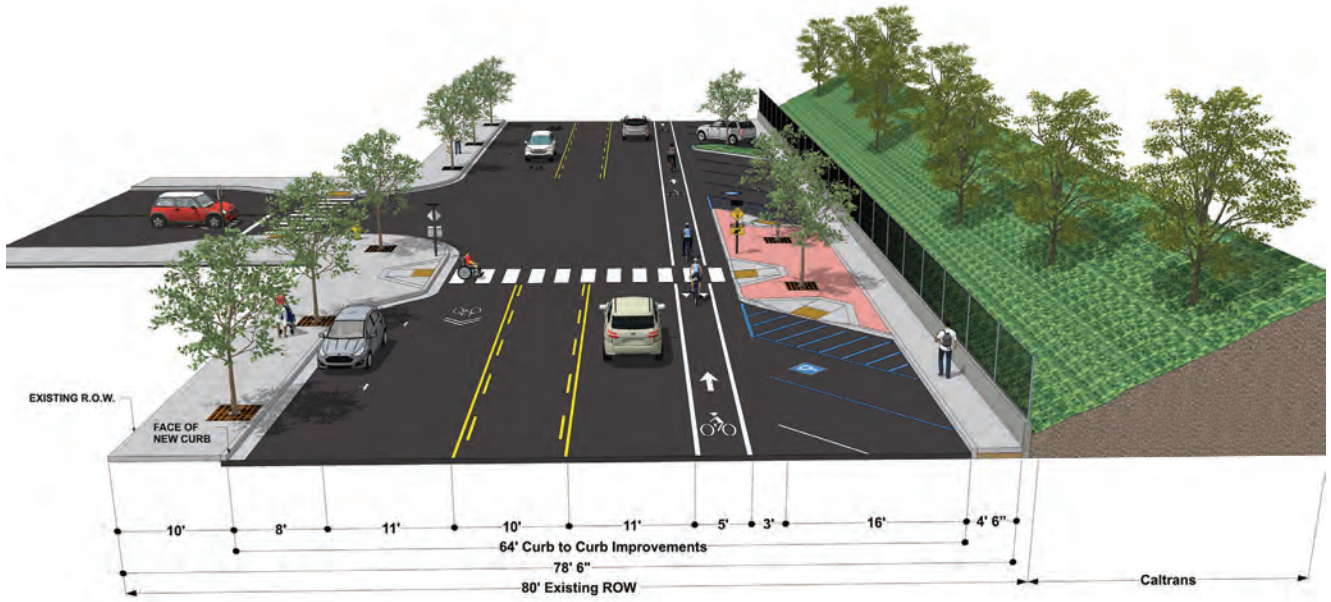



Image 10



Image 11



Image 12

4.5.4.2 Proposed Electric Shuttle System

The basic underlying transportation concept identified for the Roosevelt and 8th Street corridor is the accommodation of both on-street and off-street neighborhood electric vehicle (NEV) and on-demand and scheduled shuttle system using an enlarged street legal electric vehicle. These vehicle types (see photos) are street legal by the DMV and the California Highway Patrol on any street that is posted at 35 miles per hour or less. These vehicles are skinny enough to be used on the multi-use pathways and the one-way cycle tracks. However, they would be able to leave these routes to get a broader reach into downtown National City. The system is envisioned as being managed by the Chamber of Commerce, a future Business Improvement District, or a Parking Management organization. The proposed Parking Bonus Program could also fund some of these operations as part of their developer funding pro-

grams to reduce parking and trip generation rates. Parking meter revenues could also partially fund this program. The program could include both regularly scheduled transit shuttle routes to and from the trolley stations and the Naval Base San Diego gates during morning and afternoon employment based schedules, and then on-demand throughout the rest of the day. The on-demand could be accommodated through smart phone apps that could query and request a ride, and provide real time information on when the shuttle should arrive. The system could be provided free of charge or a nominal fee could be charged. Figure 4-16 shows possible routes in and around the Planning Area, eventually expanding into other areas of the west side of National City including the 24th Street trolley station and the Marina Waterfront areas.



NEV stop with shelter

Figure 4-16: Proposed NEV Shuttle Routes



4.5.4.3 Proposed Parking Bonus Plan that Affects Trip Generation

Part of the Smart Growth emphasis in this update is related to Smart Parking Policies. The following chapter indicates the proposed parking reduction or development bonus program envisioned to provide incentives for developments to adopt Transportation Demand Management (TDM) measures. These measures are required if the developer wants to obtain a parking reduction lower than the standard off-street parking rates generally required in the downtown area. The incorporation of many of these elements will also result in lowered trip generation or in mode-shifts to transit, walking, biking, carshare, or hail-sharing options. The number of vehicle miles reduced and/or greenhouse gases eliminated, however, will all depend on not only the number of daily trips reduced, but also on localizing trips to areas in the downtown that can service many of the daily needs of the community.

The following is a list of the TDM measures offered in the Parking Reduction Bonus Program (see Chapter 5) that could affect circulation modes, trips, and infrastructure requirements.

SITE DESIGN

- For employment uses, provide a changing room/shower
- Provide secure bike parking internal to building
- Widen adjacent public walkways beyond 8' in total width
- Provide work lofts with flex space for "at-home" work or small business

LAND USE / TENANT MIX

- Include mixed use for local serving retail & services in building
- Provide senior housing or assisted care housing

PROGRAMMATIC

- Provide cash out (money back if parking not used) for owners, renters or tenants
- Unbundle parking from leases or sales & require pay parking
- Unbundle free parking for commercial leases
- Provide priority parking for certified vanpool or carpool users
- Provide reserved space for carshare
- Tenant provided with rent credit for each employee allowed to telework

NEAR SITE FEATURES

- Provide a drop-off zone for Ridesharing such as Uber/Lyft/taxis
- Finance improvements for an enhanced transit stop
- Provide carshare reserved spaces on street (such as Car2Go)
- Provide small parking for NEV, motorcycles or scooters
- Provide additional off-site bike parking beyond on-site bike parking

FUNDING

- Provide membership in carsharing programs if available
- Provide membership in bikesharing programs if available
- Property manager to subsidize (75%) transit passes for one car tenants
- Property management to subsidize (75%) transit for on-site employers
- Property manager to subsidize (75%) passes for tenants to give to customers
- Property manager to offer links to SANDAG rideshare/iCommute/RideMatcher

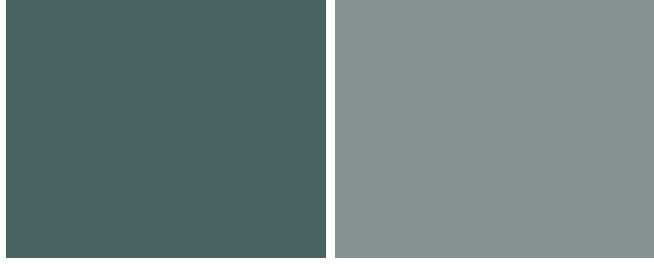

5

PARKING

5.1 PARKING IN DOWNTOWN NATIONAL CITY

The purpose of this chapter is to analyze existing parking conditions in downtown National City and plan for future growth and its associated parking demand. Recommendations and suggestions for an implementation plan to allow the City to accommodate new growth in a sustainable and innovative manner are also provided in this chapter.

5.1.1 KEY RECOMMENDATIONS

Key recommendations for Downtown National City include:

- Ensure consistent enforcement and invest in enforcement technology to make data driven decisions for implementing future regulations.
- Implement an online permit management system to improve customer service and transition to digital permitting and automated enforcement.
- Convert on-street parallel parking to angled parking where appropriate to increase parking supply and safety.
- Suggest parking ratio reductions through a bonus system that assures the implementation of parking demand management programs that will result in a lower demand for parking.
- Continue to review and update parking regulations and fines to encourage compliance and reach the City's occupancy goals.
- Implement paid parking in high occupancy areas, if required for obtaining turn-over rates.
- Establish a framework where off-street shared parking agreements can be negotiated in areas with high parking demand.
- Integrate parking equipment and infrastructure needs in the City's capital improvement planning and budgeting process.
- Establish a downtown parking benefit district.

5.1.2 IMPLEMENTATION NEXT STEPS

The implementation of the parking recommendations will occur as follows:

Table 5-1: Plan Implementation

Phase 1 (1-3) Years	Phase 2 (3-5 Years)	Phase 3 (5-20 Years)
Review enforcement program and ensure consistent enforcement	Transition to digital permitting	Add parking availability signage
Invest in enforcement technology	Complete angled parking conversion	Establish In-lieu fees
Implement online permit management system	Implement active monitoring	Continue active monitoring
Begin converting parallel parking to angled parking	Enhance enforcement	Plan infrastructure for autonomous vehicles
Review restrictions & fines	Implement parking/transit shuttle system	Implement shares parking
Establish parking bonus system for off-street parking/shared parking	Create parking manager position	
Reform off-street requirements	Initiate and refine the parking bonus system	
Establish paid parking	Integrate parking updates into budget	
Expand residential permit zones	Establish a downtown parking benefit district	
Implement oversized vehicle parking restrictions	Invest revenue	

5.2 EXISTING CONDITIONS

National City’s dense and compact urban form makes it a suitable environment for mixed-use and pedestrian friendly-development, and the urban core is well-served by multi-modal transportation options including public transit service that allows for many local and regional trips to be made without a car. National City desires to build on these existing assets and investments by pursuing “smart growth” planning and infrastructure policies to incentivize development patterns that are more environmentally and financially sustainable. By encouraging new development to occur around existing public transit nodes and bike/pedestrian infrastructure, National City is endeavoring to better accommodate projected future growth while minimizing quality of life impacts (e.g. traffic congestion) and fiscal impacts (e.g. new road infrastructure) associated with conventional, auto-dependent, sprawling development.

In order to achieve its smart growth vision, National City is undertaking a number of initiatives, including a “Smart Parking” Plan to understand how to best meet the community’s parking needs (both now and in the future) and to propose a comprehensive parking management framework based on unique local conditions and national best practices. While National City has adopted several effective parking management policies over the years, a more comprehensive plan is needed to address new parking issues that have recently become important to residents, the business community, and other stakeholders.

These issues include:

- Reducing the visual dominance of parking.
- Requiring off-street surface parking for new development be located in areas that are not visible to the primary circulation routes.
- Focusing improvements in areas that are well-served by regional transit and supported by local walking/biking infrastructure.

- Identifying cost-effective parking demand management tools that will protect residential neighborhoods from the impacts caused by parking “spillover” from adjacent commercial or mixed-use areas.
- Improving the City’s parking management functions (including integrated pricing, signage, and enforcement) to make the most efficient use of the existing parking supply and help ensure the creation of new parking supply as necessary to meet future demand.

5.2.1 DEMOGRAPHICS AND TRANSPORTATION CHARACTERISTICS

As part of the parking management study, existing demographics and transportation characteristics that could affect parking demand in National City were analyzed. This analysis focused primarily on data for commute trips from the US Census Bureau’s 2014 American Community Survey (ACS). The focus on commute trips was based on the fact that peak parking demand conditions were identified during commuter travel periods. A summary of the most relevant ACS data and findings derived from that data is summarized below.

5.2.1.1 Commuter Mode Splits

There were an estimated 25,807 workers (16 years and older) in National City in 2014. Mode splits for workers’ commute trips are:

- Drove alone/single occupant vehicle (SOV): 65%
- Carpooled: 16%
- Transit: 6.7%
- Walk, bike, taxi, motorcycle, work from home, or other means: 12.3%

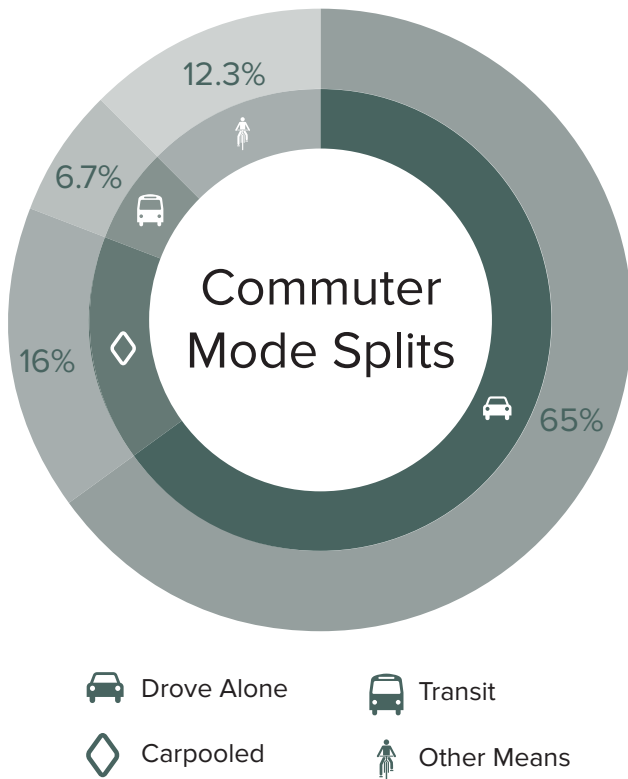

The key finding from this data is that currently over one-third of National City workers commute by more efficient and sustainable modes than single-occupant vehicles. This suggests that additional planned investments in transit and other mobility choices in the future (as discussed below), supported by appropriate parking management policies, could feasibly reduce even more of the employee commuter trips that contribute to peak period traffic and parking congestion.

5.2.1.2 Commuter Travel Times

The average commute time for all National City workers in 2014 averaged 25 minutes. Of those individuals commuting by vehicle, the average was just under 24 minutes, while those that took public transit to work spent an average of nearly 53 minutes traveling to work. The key finding from this data is that those who utilized public transpor-

tation to their place of employment, spent on average more than twice as much time commuting compared to those who drove, and reducing this “time penalty” for driving versus taking transit will be important to reducing parking demand along transit corridors and in the vicinity of transit nodes.

5.2.1.3 Household Vehicle Availability

National City households included in the 2014 ACS survey reported the following rates of vehicle availability:

- 3 or more vehicles: 38.5%
- 2 vehicles: 33.6%
- 1 vehicle: 22.3%
- No vehicle available: 4.6% (with 30.6% of public transit commuters reporting they reside in a household with no vehicle available to them)

There are two key findings from this data: 1) over one-fourth of National City households are already “low-car/no car” households and 2) a significant majority of National City workers are “choice transit riders” in that they reside in households with access to a vehicle (as only 31% of National City workers who commute by transit are “transit dependent,” residing in households without access to a vehicle). Implementing parking management policies and parking regulations for new development that accommodate existing “low car/no car households” and “choice transit riders” will be an important part of ensuring the success of this Plan and in incentivizing the growth of these markets.

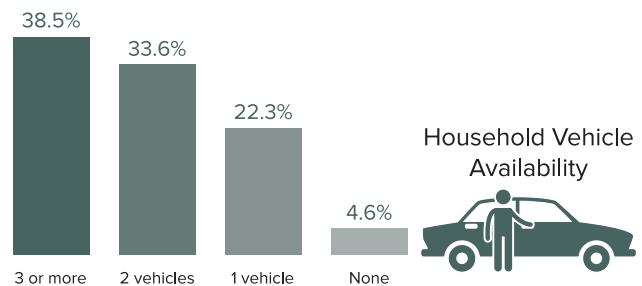

5.2.2 CURRENT PARKING POLICIES, REGULATIONS, AND PROGRAMS

After analyzing existing key demographics and travel characteristics in National City, the City’s existing parking policy framework was reviewed. The following section provides a high-level summary of the City’s current parking policies.

5.2.2.1 2030 General Plan (2012)

National City’s General Plan contains several components relevant to parking, including:

- Growth and travel demand projections through 2030 that anticipate future transportation and parking constraints. With significant population growth expected by 2030, National City will likely face growing parking congestion unless a comprehensive parking management program is implemented in the near term.
- Goals and objectives that call for parking-related policies to respond to current parking issues and mitigate against potential future parking congestion include:
 - » Establish design standards for parking facilities that reduce the visual impacts of parking lots and garages and contribute to more pedestrian-oriented and aesthetically appealing streetscapes.
 - » Maximize the efficiency of both existing and new parking facilities through expansion of shared off-street parking and angled on-street parking.
 - » Encourage transit-oriented development (TOD) and mixed-use development to reduce the parking demand associated with new development.
 - » Enforce existing on-street parking time limits.
 - » When necessary to encourage turnover and increase availability of on-street parking, implement new time limited and/or priced parking zones.

5.2.2.2 Downtown Specific Plan (2012)

Relevant parking policies in the Downtown Specific Plan (DSP) tailored to downtown include:

- Parking siting, design, and access. A primary goal of the DSP is to preserve the quality and pedestrian-friendliness of downtown streets. To support the goal of pedestrian-friendly downtown streets, the DSP includes regulations on parking locations, design, and access that:
 - » Prohibits parking facilities from being sited in any of the following locations:
 - facing National City Boulevard;
 - placed in front of buildings (prioritizing parking locations behind buildings and/or within block interiors instead); and
 - on street corners.
 - » Incentivize pedestrian-friendly parking design and operations including:
 - tree canopies and proper lighting of surface lots to ensure pedestrian comfort and safety; and
 - shared parking among different uses to reduce the overall parking “footprint” in downtown.
 - » Encourage multimodal access to and from parking facilities be provided:
 - for vehicles: via alleys and secondary streets; and
 - for pedestrians: via dedicated pedestrian and bike connections to nearby streets and transit nodes.

- **Off-Street Parking Requirements.** The DSP outlines parking requirements tailored for new development in the unique context of a walkable, mixed-use downtown that is well-served by transit. These requirements are summarized in Table 5-2 below. The Plan includes some flexibility in how development projects can meet off-street parking requirements including:
 - » requirements for most uses (including retail uses) are intended to be met with on-site parking, but consideration will be given to offsite and shared parking; and
 - » requirements for low-intensity residential uses can be met with tandem parking (one vehicle parked behind another).
- **Downtown Parking District:** The DSP also recommends the formation of a Downtown Parking District to provide parking demand management programs and support the development of additional public parking options. The stated goal of such a parking district would be to meet downtown’s overall parking needs while still accomplishing the goal of downtown revitalization by ensuring that off-street parking requirements do not create barriers for redevelopment of individual (often small) parcels in downtown. Implementation details regarding a potential downtown parking district are included in the Implementation chapter of the DSP.

5.2.2.3 San Diego Forward (2015)

The most relevant regional plan potentially affecting future parking conditions in National City is the San Diego Association of Governments’ (SANDAG) San Diego Forward plan. Key parking-related initiatives in this Plan include:

- Additional Bus Rapid Transit (BRT) and local bus routes along the I-805 corridor and throughout the city. This planned increase in local and regional transit service could help reduce parking demand along major transit corridors and in the vicinity of key transit nodes.
- Expansion of managed high-occupancy vehicle (HOV) or high-occupancy toll (HOT) lanes on I-5. HOV lanes can act as an incentive for carpooling and HOT lanes can generate revenue to fund increased investment in transit, biking, walking, and shared mobility options.

Table 5-2: Off-Street Parking Requirements for Downtown Development

Residential Uses	Required Off-Street Parking Spaces
Studio & One Bedroom Units	1
Two Bedroom Units	1.2
Three or More Bedroom Units	1.4
Non-Residential Uses	Required Off-Street Parking Spaces
Per 1,000 Square Feet of Gross Floor Area*	2.5**

Notes:

*Includes Gross Floor Area (GFA) and Below Grade Floor Area, but excludes floor area devoted to parking.

**For all non-residential uses except a) eating and drinking establishments that have a common parking area with other uses and b) outdoor dining areas.

Source: National City Downtown Specific Plan (2012)

5.2.2.4 Citywide Off-Street Parking Requirements

Citywide parking requirements for new development from Chapters 18 of the Municipal Code are summarized in Table 5-3 below.

With the exception of the mixed-uses zones, National City’s off-street parking requirements are fairly conventional. While these citywide requirements may be appropriate for more suburban parts of the city, the citywide requirements appear to be incompatible with most types of smart growth that includes infill/mixed-use development.

Section 18.45.080 of the Municipal Code includes some flexibility in how development projects can satisfy the off-street parking requirements, including:

- The Planning Commission has the quasi-judicial authority to approve a reduction in the amount of off-street parking spaces that would otherwise be required by National City zoning laws, subject to the following considerations:

- » Project applicants must demonstrate to the Planning Commission that a reduction in spaces would not negatively affect the surrounding areas, and that the parking spaces are not necessary to the development.
- » One factor the Planning Commission considers in requests for reducing off-street parking requirements is proximity to transit. Project applicants must demonstrate that a reduced number of parking spaces is feasible based on projected parking demand around transit hubs. A quarter-mile radius defines acceptable proximity in order to ensure that transit hubs are within a reasonable walking distance from the development. The transit hubs must already exist or will exist by the completion of the proposed project.

Table 5-3: Key Citywide Off-Street Parking Requirements

Residential Uses	Required Off-Street Parking Spaces
Single-family detached (less than 4 bedrooms or 2,500 SF)	2
Single-family attached	1.5
Multi-family	1.3 per 1-bedroom dwelling unit, plus 1.5 per 2-bedroom or more unit, plus guest parking (½ per unit for 20 units or less and ¼ space for each unit over 20 units). Fifty percent of guest parking may be provided along public side streets adjacent to the site.
Non-Residential Uses	Required Off-Street Parking Spaces
Bank	3 per 1,000 SF
Lodging	1 per guest bedroom, plus 1 for the manager’s unit
Medical Office	1 per 300 square feet floor area
Restaurant / bar	10 per 1,000 square feet floor area
Retail sales	1 per 250 square feet of floor area
Other Nonresidential uses	2 per 1,000 square feet
Residential units (studios, 1 bedrooms, 2 bedrooms)	1 per unit
Residential units (3 bedrooms)	1.5 per unit

Source: National City Municipal Code

- » Shared parking potential is another factor that the Planning Commission considers when deciding on requests to reduce off-street parking requirements. According to the current Municipal Code, off-street parking facilities may be utilized to meet parking demand for different uses so long as the shared parking is located no farther than 500 feet from the development(s) that are utilizing it.
- In residential projects, a reduction of one (1) off-street parking space for every carsharing vehicle space leased by a carsharing program for every 60 dwelling units.
- A provision that one (1) vehicle parking space may be replaced with multiple motorcycle spaces for every 40 parking spaces in an off-street parking facility. The motorcycle parking spaces must be located within 100 feet of the building entry. In addition to creating an incentive for space-efficient motorcycle parking, this provision also helps ensure that motorcyclists are not taking up vehicle parking spaces.
- Section 18.45.080 of the Municipal Code allows for a reduction in off-street parking requirements for new development if the project applicant creates and implements a Transportation Demand

Management (PTDM) program for the proposed project. The criteria that the PTDM program must meet are discussed in the “Parking/Transportation Demand Management” section of this document.

While the flexibility above is consistent with best practices, there are some provisions of the parking requirements that appear to undermine National City’s goals for revitalization and economic development. One example is that the current requirement associated with changing or intensifying uses requires the new use (and sometimes even the existing use) to comply with off-street parking requirements. Many communities have found that this kind of requirement acts as a:

- Barrier to the redevelopment/rehabilitation of existing structures that were built without off-street parking and are on small parcels that do not have enough area to meet the off-street parking requirements.
- Burden small/local entrepreneurs that wish to expand their growing business or start a new business by reinvesting in an existing structure but are unable to meet the off-street parking requirements for the expanded/new use.



Off-Street Parking Along National City Boulevard



Resident Only Parking Sign



Parking Enforcement Officer

5.2.2.5 Residential Permit Parking Program

National City has a residential parking permit program in place which designates permit-only parking districts in neighborhoods that consistently experience on-street parking occupancy rates over 70% (see Figure 5-1 for a map showing the extent of these areas). An annual fee is charged to residents for each permit, and this program helps to ensure that streets in residential neighborhoods primarily serve the parking demand generated by residents of these neighborhoods (and their guests) by reducing parking spillover impacts from downtown and other commercial or mixed-use areas.

5.2.2.6 Parking Enforcement Program

A ride-along with the National City Parking Enforcement Department in November 2015 provided insight into the following enforcement challenges:

Staffing and Oversight. At the time of the audit the City had three full-time Parking Regulations Officers (PROs). This number fluctuates, but the maximum number of officers the City has had at any time is five. There is little daily direct oversight of the department, although the Director of Neighborhood Services meets with staff once every two weeks to keep track of what they are doing and what their numbers are.

Jurisdiction and Routes. PROs only manage on-street parking in the downtown area. The PROs have no defined routes or designated area which each officer enforces. Often times a PRO will issue a citation as a result of being dispatched by the local Police Department. A lot of time is spent responding to Police requests.

Equipment. PROs have handhelds, but they are outdated and in need of replacement. PROs carry paper logs which have to be entered manually into the computer system when they return to the office. This results in not only a manual process but an inefficient and time consuming effort. The Enforcement Department has four vehicles which are managed through a lease agreement with Enterprise. The fleet is comprised of two recent model Toyota Tacoma pickup trucks, an older Ford Ranger pickup truck, and a Cushman golf cart. The Ford Ranger however is nearing the end of its useful life and due for replacement.

Restrictions and Time Limits. Section 11.32.190 of the Municipal Code describes on-street parking restrictions and how these restrictions are indicated with varying curb colors and sometimes supplemented with signage. The restrictions are indicated with the following curb markings:¹

- Red: No stopping, standing, or parking at any time except as specifically permitted by the Vehicle Code (e.g. a bus may stop in a red zone marked or signed as a bus zone).
- White: No stopping, standing, or parking for any purpose other than loading or unloading of passengers, which shall not exceed 3 minutes. Such restrictions shall apply between 7am and 6pm of any day except Sundays and holidays. When a white zone is in front of a hotel or hospital, the restrictions shall apply at all times. When a white zone is in front of a theater the restrictions shall apply at all times except when such theater is closed.
- Yellow: No stopping, standing, or parking at any time between 7am and 6pm of any day except Sundays and holidays for any purpose other than the loading or unloading of passengers or materials. The loading or unloading of passengers shall not exceed 3 minutes and the loading or unloading of materials shall not exceed 20 minutes.
- Green: No standing or parking for longer than 15 minutes at any time between 7am and 6pm of any day except Sundays and holidays. Green zones must be specifically designated by resolution of the City Council.



Parking Enforcement Handheld Device



Time Limit Parking Sign



Colored Curb Zone

Figure 5-1: Existing Residential Permit Parking Zones

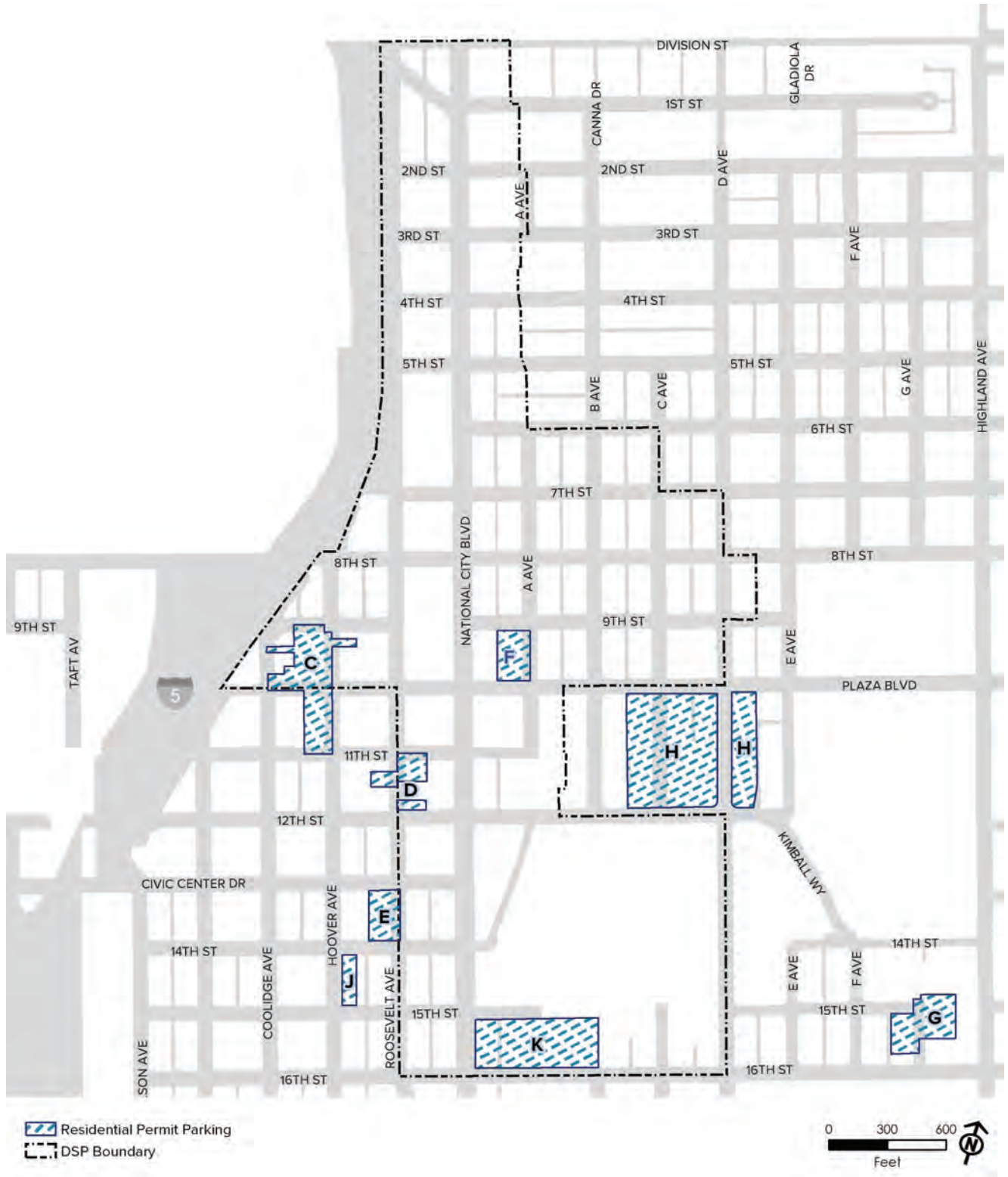

Where on-street parking time limits exist, they range from 1-hour maximum to 4-hours maximum. In the downtown area, time limits are in effect between 7am and 6pm (excluding Sundays and holidays) with a maximum of one hour. Observed time limits on some blocks are only denoted with one sign; this can add to confusion for motorists and can undermine the credibility and effectiveness of parking enforcement when time limit violations are routinely protested and/or dismissed if motorists complain that the time limits were not clearly posted.

Primary Violations. The primary violations the PROs spend most of their time enforcing are time limit violations, disabled parking violations, and red curb (no parking) violations.

A close review of National City’s parking violation fee schedule determined that the City does have a citation penalty in place for all of major parking violations, so there appears to be no deficiency in the City’s existing authority to issue parking citations.

One key finding that emerged from reviewing the enforcement program and the fine schedule for parking violations is that National City does not have a system in place for discouraging those violations which have the most negative impacts on the safety, efficiency, and sustainability of the transportation system, such as double parking, sidewalk parking, or exceeding time limits. Some communities focus increased enforcement resources or impose higher fine amounts for these and similar violations that have the greatest negative impacts on the overall functioning of the transportation system for other travelers (and quality of life for residents).

5.2.2.7 Parking/Transportation Demand Management Program

An important component of a comprehensive parking program is to invest in initiatives to help make the most efficient use of the existing parking

supply through parking/transportation demand management (PTDM). PTDM programs focus on reducing parking and traffic congestion and associated negative impacts through the deployment of financial incentives, multimodal choices, and information/marketing campaigns that encourage travelers to shift their mode of travel, time of travel, or route/destination of travel.

While National City does not have a comprehensive, dedicated PTDM program, there are several good PTDM policies in place, including the following:

- Businesses are encouraged to offer a flexible schedule for employees as well as incentives for transit use. Bicycle parking should be provided at new developments to help promote the use of alternative modes of transit.
- National City also works with local school districts and schools to try to ensure that school transportation programs are as streamlined and efficient as possible to further reduce vehicle trips.

In addition, Section 18.45.080 of National City’s Municipal Code allows for a reduction in off-street parking requirements for new development if the project applicant creates and implements a PTDM program for the proposed project. For the reduction in off-street parking requirements to be approved, the PTDM program must include the following:

- A projected reduction in parking demand expressed as a percentage of overall parking demand and the basis for such reduction.
- The PTDM program actions to be taken by the applicant to reduce the parking demand.
- A requirement by the applicant to periodically monitor whether the projected reduction is being achieved.
- A commitment and plan whereby the applicant shall provide additional parking spaces in an amount equivalent to the reduction should the PTDM program not result in the projected reduction in parking demand.

5.2.3 PARKING INFRASTRUCTURE

5.2.3.1 Off-Street Parking Supply

National City currently has no publicly available off-street parking facilities. A summary of a limited number of privately-operated off-street parking lots is shown in Table 5-5 and on Figure 5-2 below. It should be noted that this list is not an exhaustive inventory of all privately-operated off-street parking lots in National City. Instead, these facilities were selected if the lot met two criteria: 1) appeared to have a minimum capacity of 20 parking spaces and 2) was identified as a potentially feasible location for shared and/or public parking in the future.² A key finding of this inventory of privately-operated off-street lots is that they represent a significant and cost-effective opportunity to increase the supply of shared/public parking spaces by nearly 800 spaces.

5.2.3.2 On-Street Parking Supply

A inventory of the on-street parking supply in the four priority study areas has been shown in Figure 5-3. Additionally, the on-street parking supply in these four study areas is summarized in Table 5-6.

A key finding of this analysis is that there is a significant amount of on-street parking supply in the study areas: the 1,006 spaces represent 236 more spaces than the 771 spaces in the 24 privately-operated off-street parking facilities inventoried for potential shared/public parking use. Since on-street parking is the most cost-effective, land-efficient, and customer-friendly method for meeting parking demand generally and short-term parking demand specifically, it will be critical for National City to focus on enhancing the management of this “low hanging fruit” parking resource during implementation.



National City Education Village Parking Garage

Figure 5-2: Privately-Operated Off-Street Parking Lots

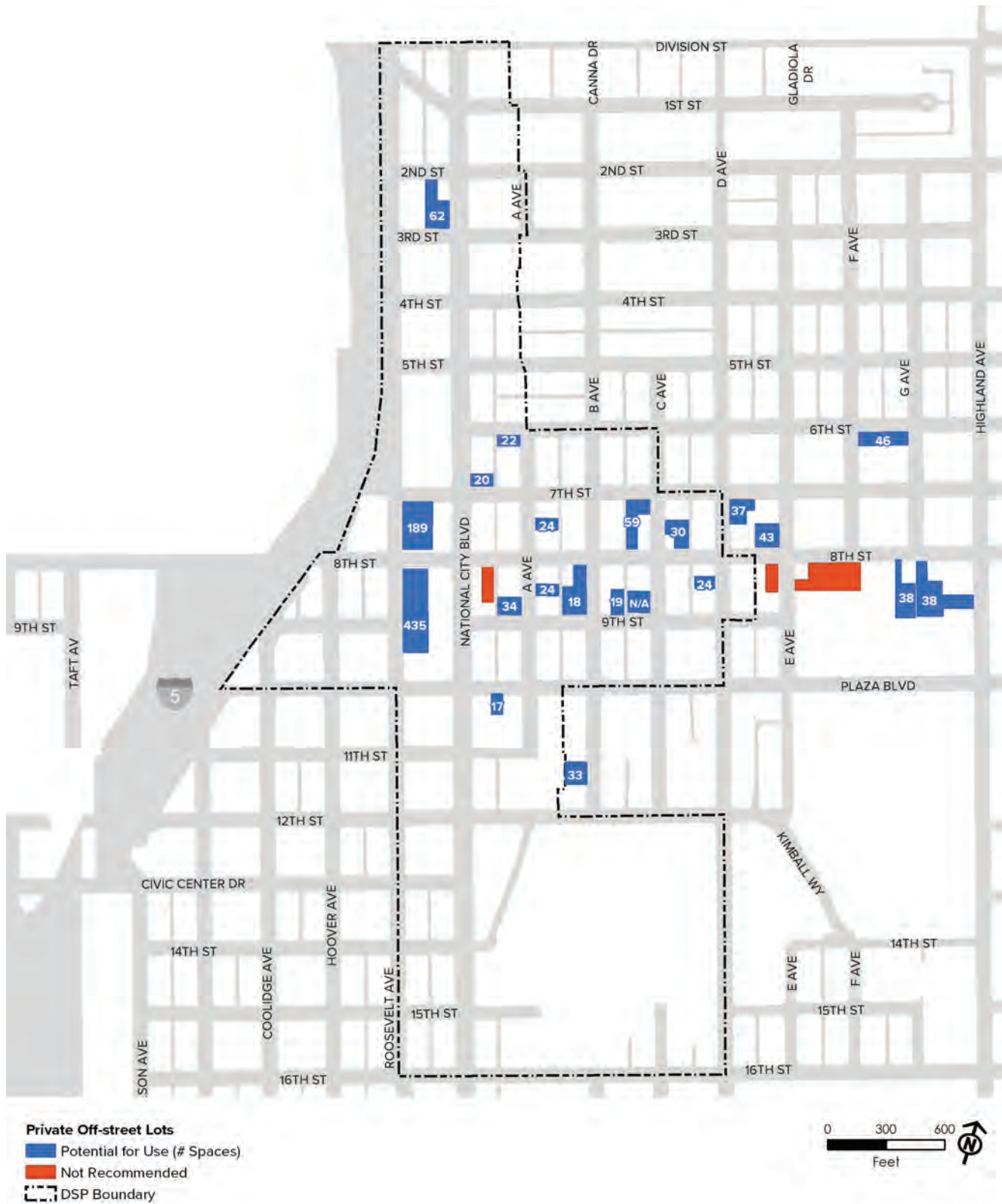

Table 5-4: Privately-Operated Off-Street Parking Lots

Name	Location	Spaces (20 min.)
Church & Tenant Parking	Corner of G St. & East 6th	44 (2 ADA)
St. Mary's Catholic Church (1)	Corner of East 8th & E St.	43 (2 Reserved Spaces)
St Mary's Catholic Church (2)	Corner of East 7th & D St.	33 (4 ADA)
Bank of America	Corner of East 7th & C St	56 (3 ADA)
Funeria Del Angel	Corner of East 6th & A St	22
McDini's Restaurant	Corner of East 8th & A St.	23 (1 ADA)
Old Schoolhouse Square Lot	8th & F	[Pending]
Tooth Fairy Dental Lot	Corner of East 8th & D St.	24
Empty Lot	Corner of East 9th & C St	[Pending]
Auction House Lot	Corner of East 8th & B St	18 Open
Appliance Parts Center Lot	Corner of East 9th & B St	18 Available (1 ADA)
G - Southwest Lodge	Corner of East 12th & B St.	31 (2 ADA)
Big Ben's Market & Grill House	Corner of East 8th & A St.	22 (2 ADA)
Union Bank	Corner of East 8th & A St.	32 (2 ADA)
NC Blvd. & Plaza Lot	Corner of NC Blvd & E Plaza Ave	16 (1 ADA)
Plaza Josha	Corner of East 8th & E St.	27 (2 ADA)
Multi-Use Lot	East 8th b/w Highland & G	36 (2 ADA)
International Bible Baptist Church	Corner of East 8th & G St.	36 (2 ADA)
Complete Family Medical Care	Corner of East 8th & C St	28 (2 ADA)
Bayview Condos	Corner of East 8th & NC Blvd	[Pending]
Community College	[Pending]	[Pending]
Empty Lot	Corner of NC Blvd & 7th	20
Aunt Emma's Pancakes	NC Blvd (Btw 2nd-3rd)	59 (3 ADA)
Clarion Hotel	[Pending]	183 (6 ADA)
TOTAL		771 (35 ADA)

5.2.4 ON-STREET PARKING FIELD SURVEYS

5.2.4.1 On-Street Angled Parking Survey

A survey of the potential for converting existing on-street parallel parking to angled parking was conducted in priority areas. The two study areas are shown in Figure 5-4 below, with the estimated net gain in parking spaces annotated for each block face where conversion from parallel to angled parking is potentially feasible.

Table 5-5: On-Street Parking Supply in the Four Priority Study Areas

Street	Spaces
West National City Blvd.	156
West Side Streets	216
East National City Blvd.	149
East Side Streets	169
8th Street	97
South Side Streets	95
North Side Streets	124
TOTAL	1,006



Angled Parking along 8th Street



Angled Parking on C Avenue

Figure 5-3: On-street Parking Inventory Map

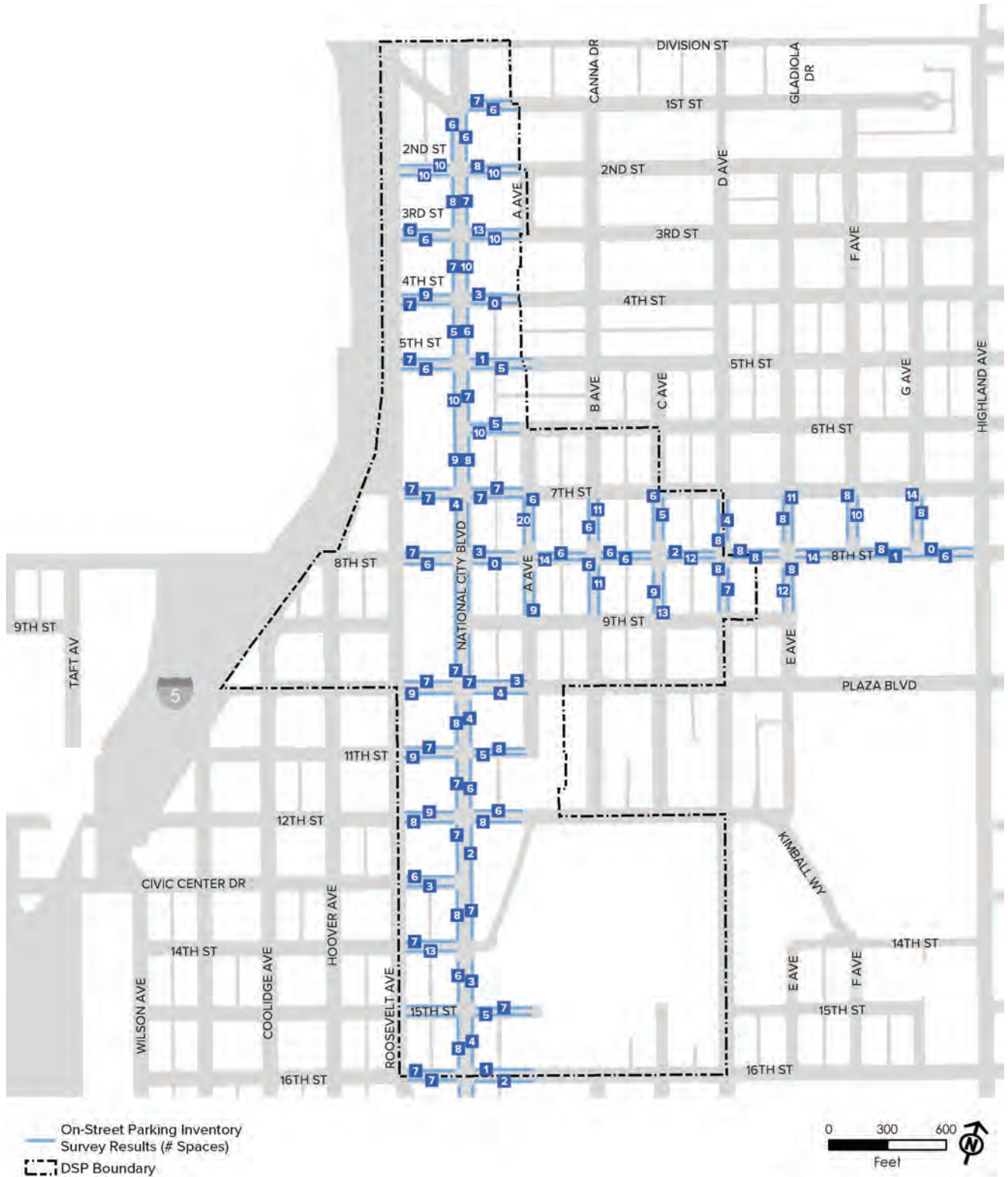
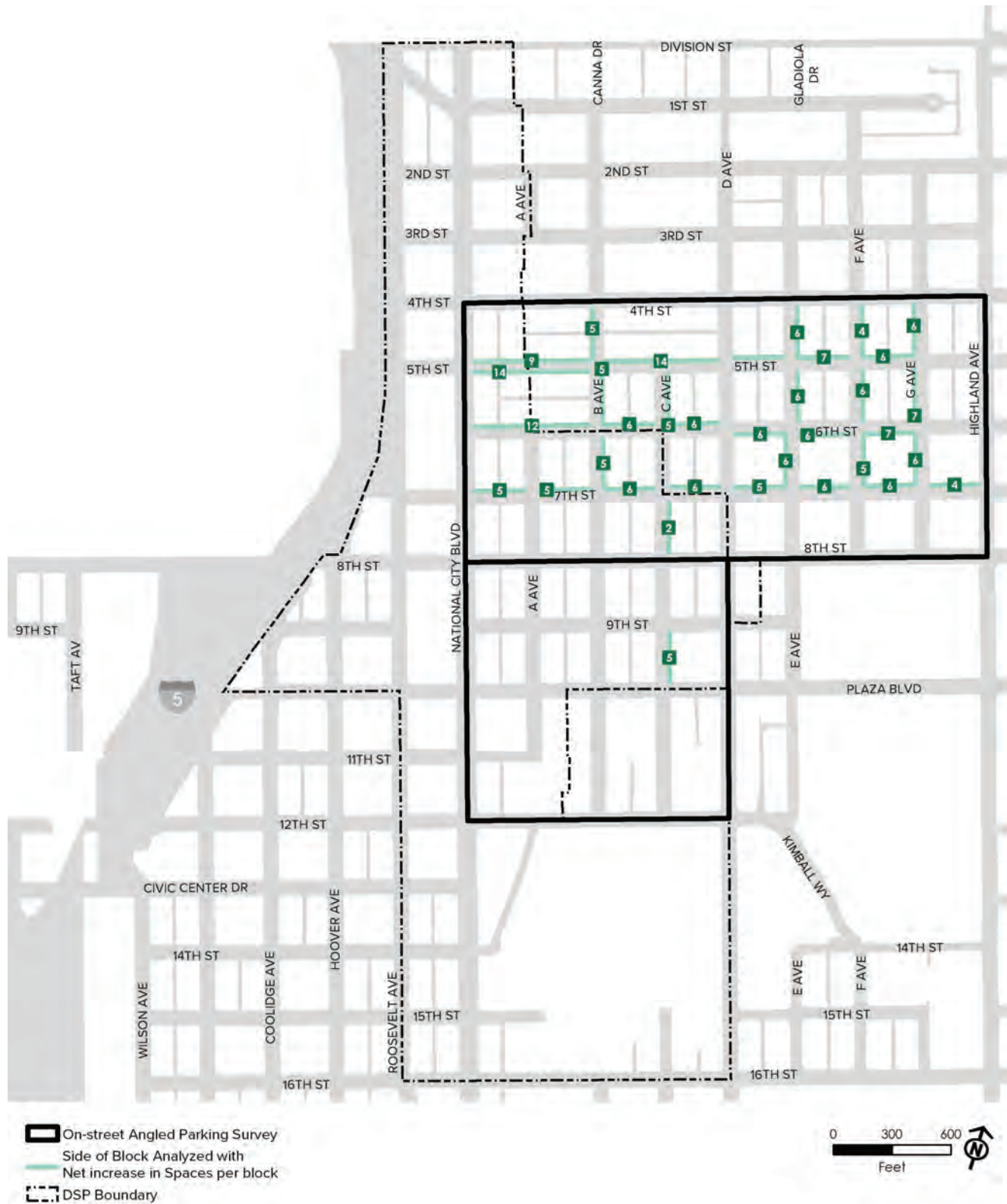

Figure 5-4: Potential On-Street Angled Parking Survey



A summary of key findings from the on-street angled parking survey data collection is below. See Appendix 9.2 for the complete dataset supporting these findings.

- 35 block faces were identified in the Grid 1 and Grid 2 study areas that were potentially feasible for conversion from parallel parking to angled parking.
- By converting to angled parking on those 35 block faces, the on-street parking supply could be increased from 394 spaces to 614 spaces, a net gain of 220 spaces.
- As a result, conversion to angled parking on these 35 block faces would provide a cost-effective way to increase the on-street parking supply in these 2 study areas by 36%.
- By narrowing the effective and/or perceived width of the through travel lanes on these streets and thereby potentially slowing vehicle travel speeds, the conversion to angled parking would likely also have some beneficial traffic calming and traffic safety effects as well.
- Roosevelt Avenue is being considered for conversion to angled parking. Under the current plan, the east side of the street would have its parking removed, but the west side would substantially increase in parking due to conversion of parallel to angled spaces. 162 spaces can be created that replace the existing 82 (there are currently a total of 172 spaces, but approximately 90 of them are taken up by trucks).

On-street parking occupancy survey. On-street parking supply numbers and demand data were collected in two (2) priority study areas. These two priority study areas are shown in Figure 5-5.



Potential Roosevelt Avenue Reconfiguration with Angled Parking

Figure 5-5: On-Street Parking Occupancy Survey: National City Blvd & 8th Street Study Area

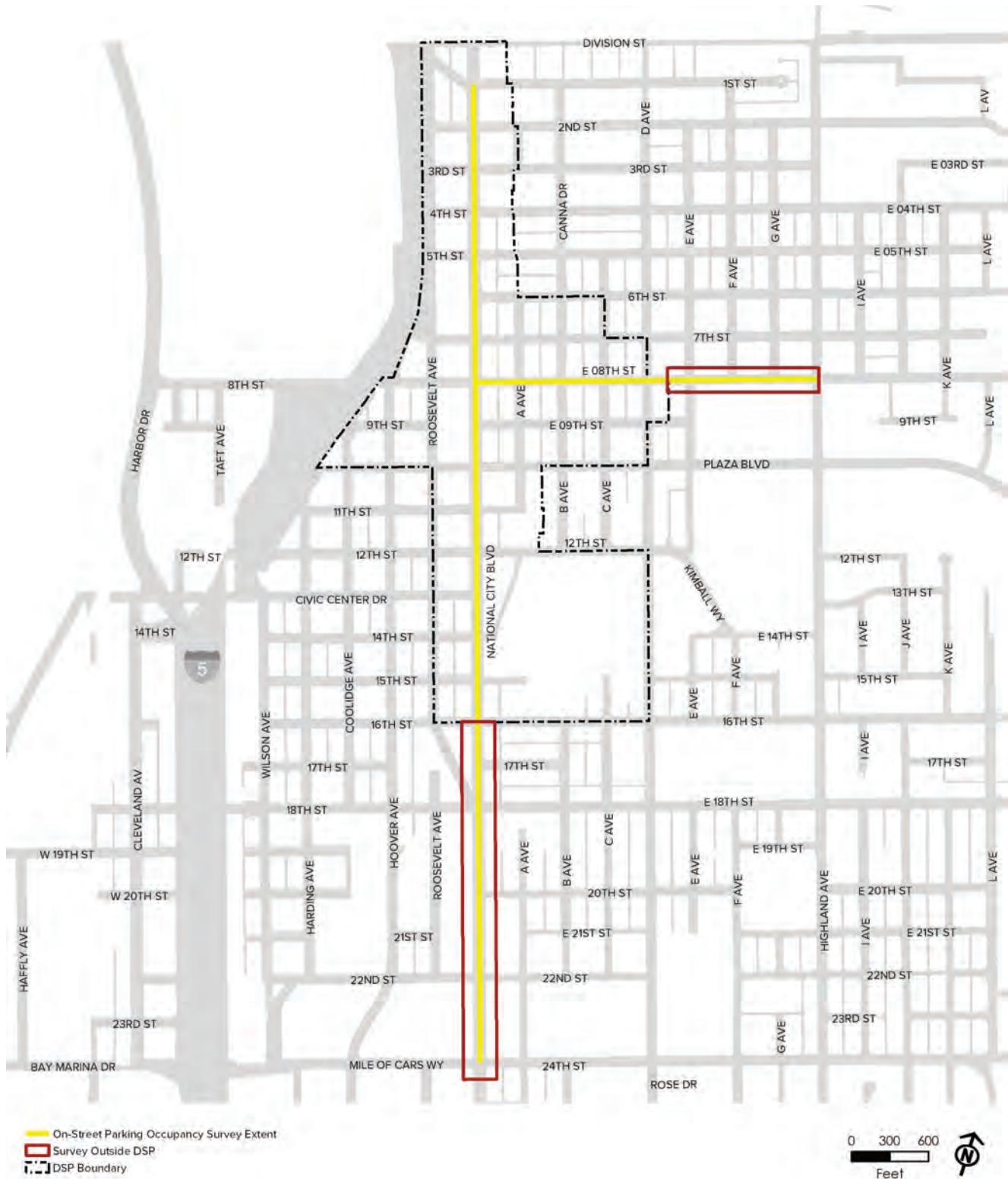

Table 5-6: On-Street Parking Average Weekday Occupancy Rates

Time Period	National City Blvd. West	National City Blvd. East	National City Blvd. Combined	8th St. South	8th St. North	8th St. Combined
4am-7am	7%	8%	7%	46%	18%	33%
10am-1pm	61%	51%	56%	67%	27%	47%
4pm-7pm	58%	51%	55%	63%	40%	52%

Data was collected on two typical weekdays (Tuesday, 2/25/16 and Wednesday 2/23/16) at the following three (3) time periods:

- Overnight: 4am-7am
- Late Morning: 10am-1pm
- Early Evening: 4pm-7pm

These three time periods were selected because they were determined by the project team to have distinctly different parking demand patterns. Table 5-7 above summarizes the average weekday occupancy rates (rounded up) for on-street parking observed in each study area across all the data collection periods.

A detailed breakdown of key findings from the on-street parking occupancy survey data collection is below. See Appendix X for the complete dataset supporting these findings.

- National City Boulevard:
 - » Parking availability was plentiful overnight along National City Boulevard, reaching over 80% occupancy on only 3 occurrences over the course of the two data collection nights.
 - » The 200 E Block of National City Boulevard did not have sufficient parking availability at any time on Tuesday.
 - » Late mornings and early evenings were busy times for the 1600 – 1800 blocks of National City Boulevard.
 - » Many blocks that are at 0% occupancy overnight become 100% occupancy for the rest

of the day in the downtown core (e.g. the 800 W, 1600 E, 2200 W, and 2300 W blocks of National City Boulevard).

- National City Boulevard West Side Streets:
 - » There were no blocks at 100% occupancy overnight within the National City Boulevard West study area on Tuesday or Wednesday. The highest occupancy percentage observed overnight between 4am and 7am on both days was 67%.
 - » During the late morning on Tuesday there were a total of eight (8) blocks with over 80% occupancy and during the early evening there were seven (7).
 - » Wednesday during late morning had the highest number of blocks with an occupancy percentage of 80% or more. Sixteen (16) out of the thirty-two (32) total blocks evaluated (50%)lacked sufficient parking.
- National City Boulevard East Side Streets:
 - » As opposed to National City Boulevard and the west side streets, the east side streets have some cases of over 80% occupancy overnight; six (6) cases were recorded on Tuesday and eight (8) on Wednesday. Additionally, the majority of these were at 100% occupancy.
 - » 17th E to 22nd E of the 10 blocks were heavily occupied during the late morning and early evening times on both Tuesday and Wednesday. The majority of these blocks were at 100% occupancy.
 - » Blocks that tended to be full in the late morning often stayed full in the early evening.

- East 8th Street:
 - » The 200 S, 400 S, and 600 S blocks of E 8th Street were above 80% occupancy for a significant amount of the data collection times on Tuesday and Wednesday. These were the three blocks that had the most consistent availability constraints.
 - » The peak parking demand times were late morning on Tuesday but early evening on Wednesday.
- 8th Street South:
 - » The 800 W block of A Avenue was at or around 100% occupancy during all three data collection periods across both days.
 - » Overnight on Wednesday was the time-period that had the most blocks over 80% occupancy, and many of these same blocks continued to have high rates of occupancy throughout the day.
- 8th Street North:
 - » On Wednesday, the 700 W block of G Avenue was the only block to experience over 80% occupancy overnight out of the two study days.
 - » Early evening on Tuesday had the most occurrences of blocks with over 80% occupancy.
 - » The 700 E block of G Avenue had high rates of occupancy throughout the day on both Tuesday and Wednesday.

On-Street Parking on 8th Street



5.3 RECOMMENDATIONS

5.3.1 OVERVIEW

Based on the key findings from the existing conditions analysis, including the field surveys of on-street and off-street parking, a number of recommendations are proposed to help National City create a comprehensive parking management framework necessary to achieve the future vision for the community. Because not all recommendations can or should be implemented immediately, a phased implementation plan that outlines the suggested time frame for moving forward with each of the recommendations in the short-term, medium-term, and long-term is proposed in Table 5-8.



Example of Time Restricted Parking Sign



Parking Enforcement Vehicle

Table 5-7: Summary of Recommendations and Suggested Implementation Phasing

National City Implementation Plan	
Phase 1 (1-3 Years)	
Review enforcement program and ensure consistent enforcement	Review program to ensure it has a clear strategic direction, appropriate oversight, and necessary financial resources.
	Improve enforcement that will allow the City to make data driven decisions for implementing regulations.
	Develop enforcement schedules and routing to maximize enforcement coverage and frequency.
Invest in Enforcement Technology	Conduct site visits and/or pilot program to test equipment.
	Purchase one license plate recognition system to improve enforcement efficiency.
	Purchase 1 dedicated enforcement vehicle for use with license plate recognition cameras.
	Purchase wheel imaging system to replace chalking methods for time limited parking enforcement.
	Integrate with online permit management system for seamless permit enforcement.
Implement Online Permit Management	Expand existing system to include an online permit management system.
	Implement an automation system that saves the City time and improves customer service.
	Create an online customer portal and provide other online applications.
Begin converting parallel parking to angled parking	Begin converting parallel parking to angled parking near 8th Street to add additional parking where occupancy is typically the highest.
Review Restrictions & Fines	Ensure restrictions and fines are tailored to encourage compliance and prevent those violations that have the most negative impacts on the parking/transportation system (e.g. violation of time limits), residents' quality of life, and non-residents' visitor experience.
Establish parking bonus system for off-street parking/shared parking	Establish a parking bonus system for off-street parking/shared parking that reduces parking requirements or awards unit bonuses to developers that work to reduce VMT and promote PTDM.
Reform Off-Street Requirements	Reform off-street parking requirements in conversation with technical stakeholders, business/property owners, and the real estate community.
	Ensure that parking needs are being met in the most efficient way possible.
	Reduce barriers to redevelopment in mixed-use districts and transit corridors through the addition of a parking reduction or development bonus system.
Establish Paid Parking	Install single space parking meters on E. 8th Street between National City Blvd and "D" Avenue, and "A" Avenue between E. 7th Street and E. 9th Street to increase parking turnover for local businesses and allow for more efficient enforcement.
	Implement paid parking in high occupancy areas to promote turnover and achieve availability targets.
Expand Residential Permit Zones	Protect primarily residential neighborhoods from spillover parking.
	Expand zones based on anticipated impacts of consistent enforcement.
Implement Oversized Vehicle Parking Restrictions	Prohibit oversized vehicle parking on Roosevelt Avenue to increase parking capacity for employees and customers of local businesses and future residents.

Table 5-7: Summary of Recommendations and Suggested Implementation Phasing (Cont.)

National City Implementation Plan	
Phase 2 (3-5 Years)	
Transition to Digital Permitting	Phase into solely digital permitting with the use of License Plate Recognition for Residential Permit Parking Zones.
Complete Angled Parking Conversion	Complete the angled parking conversion on all eligible streets.
Implement Active Monitoring	Assess downtown weekday and weekend day occupancy rates on an annual basis to determine any necessary adjustments to time limits and parking rates.
Enhance Enforcement	Purchase another dedicated enforcement vehicle.
Implement Parking/Transit Shuttle System	Obtain financing for the shuttle multi-use path, for electric shuttle vehicles and for staffing. This can be administered through the parking district, the chamber of commerce or through a private contract.
Create Parking Manager Position	Establish a position for a Parking Manager that will oversee parking operations. This will allow the City to have proper management and oversight of the parking program.
Initiate and Refine the Parking Bonus System	Utilize the Parking Bonus Worksheet to incentivize developers by allowing unit bonuses or parking reductions for locations that implement transportation demand management tactics and parking management tools.
Integrate Parking Updates into Budget	Integrate parking equipment and infrastructure needs into the City’s capital improvement planning/budgeting process.
Establish Parking Benefit District	Establish and formalize the downtown parking benefit district to allow the City to manage existing supply efficiently and implement improve district-wide programs to reduce parking demand and add new parking supply.
Invest Revenue	Invest revenue into parking & transportation improvements



Neighborhood Electric Vehicle

Table 5-7: Summary of Recommendations and Suggested Implementation Phasing (Cont.)

National City Implementation Plan	
Phase 3 (5-20 Years)	
Add parking availability signage	Add parking availability signage along major arterials and at garage entrances.
Establish In-lieu fees	Implement a program that allows developers to pay a fee per space in-lieu of providing the required spaces.
Continue Active Monitoring	Continue to assess downtown occupancy rates on an annual basis to determine the need for time limit adjustments and/or paid parking.
Plan Infrastructure for Autonomous Vehicles	Have a foresight for technological developments will allow for a smoother transition for National City, since autonomous vehicles will change parking demands in the future.
Implement Shared Parking	Negotiate off-street shared/public parking agreements in areas with high parking demand with owners of privately-operated off-street parking facilities.



Parking Availability Signage

This study recommends the implementation of the short-term recommendations to begin immediately upon the consideration and potential adoption of this Plan. For this reason, greater implementation details are generally provided for short-term recommendations. Some of the medium-term and long-term recommendations are linked to the successful completion of short-term recommendations. However, preliminary planning for some of the medium-term and long-term recommendations can and should begin as soon as opportunities and resources allow. This priority is needed due to the possibility that some of these recommendations may have an extended lead time (e.g. establishment of a Downtown Parking Benefit District) or likely ongoing, iterative nature (e.g. negotiation of off-street shared parking agreements).

5.3.2 PHASE 1 (1-3 YEARS)

Review enforcement program to ensure the program has clear policy/strategic direction, appropriate leadership oversight, and the financial resources to fully support the City's parking management priorities. It is imperative to have an effective enforcement operation to ensure residents and visitors can easily understand and comply with parking regulations. Quality enforcement will allow the City to make data driven decisions for implementing regulations in the future. Near-term opportunities that could significantly improve parking conditions are described below.

5.3.2.1 Curb markings and signage

Clearer curb markings and signage to indicate on-street parking time limits and other restrictions. The current time limits are located inconsistently and sometimes offer varying information on the same block. Curb markings are not present on many curbs that need them such as near a fire hydrant or a bus stop. Additionally, curb markings are inconsistent with their associated signage. An example is disabled parking signs: as shown in Figure 5-6, the sign on 8th Street is a completely different design to the signs on National City Boulevard and 6th Street.

Figure 5-6: Example of Inconsistent Signage



8th Street



National City Boulevard

Figure 5-7: Example of Inadequate Signage



Figure 5-8: Inadequate Curb Marking Example



Additionally, on-street parking with time restrictions or priced parking should also have a sign posted at the beginning and end of the parking area the regulations apply to so that drivers are aware of the parking rules regardless of the direction they are coming from. In the example from 8th Street shown in Figure 5-7, there is no sign indicating that parking on this block face is subject to 2-hour time limits except at end of the block (near the large truck in background of the picture) which is clearly not adequate to help motorists easily understand and comply with the relevant parking restrictions.

Furthermore, all curb markings should be paired with corresponding text on the curb and/or nearby signage to make sure that the meaning of the parking restrictions indicated by each colored curb is clear. Optimally, every parking restriction in every zone would have a curb color, curb text with a brief explanation, and nearby signage with more detailed explanation. Figure 5-8 below shows an example from National City Boulevard and 2nd Street that is an active “no parking” zone; the curb should be at least be painted visibly red, but the paint is extremely faded. This is just one example of numerous parking restricted areas in and around downtown area which require painting to improve the customer-friendliness of the on-street parking experience and the consistency of enforcement for existing parking restrictions.

5.3.2.2 Oversight

Based on site observations, there needs to be dedicated oversight of the parking enforcement department. Currently the department is managed by National City’s Neighborhood Services Manager. Although this manager has bi-weekly meetings with staff to review numbers, there is no direct daily supervision. It would also be advantageous for the City to have a dedicated shift supervisor assigned to oversee the operation. This person could help conduct random field audits of enforcement staff, along with management ride-alongs to ensure compliance.

In addition, detailed job guidelines and policy and procedures need to be created to cover all aspects of the enforcement work. A manual of policies and procedures is necessary for guidance and direction for the PROs. At the same time, there must be direction on the expected enforcement of each assigned beat/route. A manual is not just about personnel issues; it is also a “how to do the job” guideline, spelling out policies of enforcement so that every officer enforces in the same manner (in fact, many agencies may call this a training manual).

A beat plan with maps and listings of signage, meter zones, and priorities would also be a very helpful tool. This beat plan along with the manual both must be maintained and updated on a regular basis in order to be useful tools.

5.3.2.3 *Defined routes*

Defined routes (areas) should be created and should occur at specific times throughout the day. This will ensure that all areas of the city are being covered and appropriately enforced. The main focus and primary duty of a PRO should be to enforce priority parking violations along their route, especially time limits. Currently PROs are pulled in many different directions which inhibits their ability to do their core job functions.

In order to implement other longer-term recommendations (e.g. negotiate shared/public off-street parking agreements), the City must first confirm that the existing on-street parking supply is being managed and enforced as efficiently as possible. For example, the Southwestern College parking garage appears to have substantial capacity and is a primary target for a potential shared parking agreement. However, upon further assessment, it was identified that the time limits surrounding the college are not consistently enforced, therefore the school population primarily parks at various on-street locations surrounding the college. If the on-street parking time limits were consistently enforced, it would encourage the school population to use the garage which would not only reduce spill-over parking impacts but would also ensure that the utilization data for both on-street and off-street parking in this area were accurate, so that the correct data can inform decision-making about where off-street shared parking agreements will be beneficial (or where new off-street parking supply is actually needed).

Figure 5-9 outlines the short-term implementation plan for enforcement based on time restricted parking and future residential permit parking zones. It is recommended that the City implement a cyclical route that allows for a minimum of 3-4 patrols per shift for Areas 1 and 2. The route frequency for Area 3 is dependent upon the rules to be enforced.



On-Street Parking behind Southwestern College

Figure 5-9: Phase 1 Implementation Plan

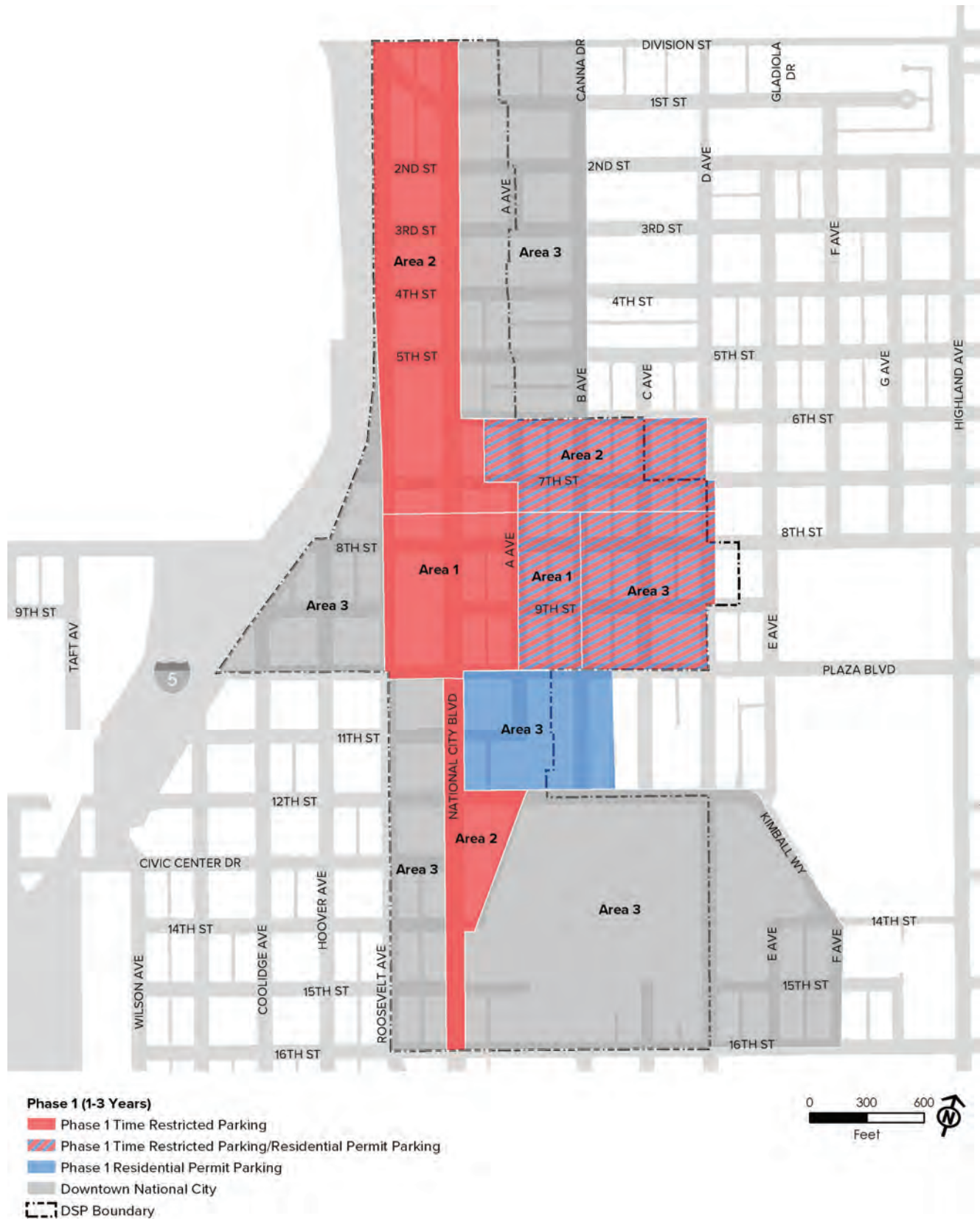

Enforcement Technology will allow for dynamic parking management and enforcement. Parking occupancy sensors, real-time information on parking availability, enforcement handhelds, License Plate Recognition (LPR), and wheel imaging systems can vastly improve program efficiency. Best practice technology will provide enforcement officers with the tools they need to do their difficult job more efficiently while providing consistent and transparent enforcement.

5.3.2.4 Vehicles/LPR

The Parking Enforcement Department has an aging fleet which is not fuel efficient. This study recommends replacement of the oldest vehicles that are reaching the end of their useful life with smaller, more maneuverable, and more fuel-efficient vehicles suitable for busy city streets. It is also recommended that these be dedicated enforcement vehicles because of their anticipated use with LPR. In the short-term, the City should purchase one new electric parking enforcement vehicle equipped with LPR technology to provide more efficient parking enforcement.

This Study recommends that the City concurrently phase in LPR technology as new enforcement vehicles are procured. LPR provides several key advantages:

- Enforcement routes can be completed faster and more frequently.
- Every vehicle is checked for compliance.
- Multiple permits are enforced at once.
- Scofflaws are automatically identified so repeat violators are caught on daily patrols.
- Automation removes the potential for human error.
- Customers take notice when enforcement is consistent resulting in increased compliance with rules and paying fines.

A wheel imaging system with the LPR can be utilized for digital chalking of vehicles. If the City decides not to opt for LPR there are certain enforce-

ment handhelds which have a digital chalking function. This saves time from the PROs having to manually chalk tires on all vehicles.

At the time of this writing, the current cost of a new vehicle with LPR technology attached is priced at around \$80,000. However, new vehicles with LPR technology and/or standalone LPR technology that can be used with existing vehicles leased for less (and many vendors will allow for short-term free use to pilot test the equipment). This study recommends that the City begin to pilot test new enforcement vehicle options and LPR technology.

5.3.2.5 New handhelds

The current handhelds are outdated and do not have the functionality required for a modern parking enforcement operation. The City should look at procuring new handheld enforcement technology linked to an intuitive backend system, in order to automate the process. In turn, this may eliminate the process of PROs manually entering all of their citations. As mentioned previously, not only is this time-consuming but it may lead to human error with the inputting of data.

Develop automated administration of parking citations and permits, including customer-friendly applications such as online payments. The City should immediately pursue automation of its existing parking operations, including those functions which in many communities typically generate the highest levels of frustration and complaints from motorists (e.g. paying parking tickets and applying for (or renewing) residential parking permits.

Particularly important, the introduction of automated citation processing will create a more transparent financial audit trail. To this end, six (6) main ways have been identified to improve National City's parking citation processing services, including:

1. Integrate permit management system with a LPR vendor.
2. Request a daily activity log feature through Data Ticket.

3. Update the handheld ticket writers to include the following:
 - a. real-time transmission;
 - b. ability to take, send, and view color photos;
 - c. ability to record, send, and view video and audio recordings;
 - d. ability to view prior citations, warnings, and valid permit information during the citation issuance process;
 - e. the use of a chalking feature;
 - f. the use of a default citation;
 - g. transition from the existing web user interface City Personnel utilize to an updated interface with enhanced capabilities; and
 - h. customize the public-facing web user interface to pay and appeal parking citation to mimic the City’s existing website.
4. Utilize franchise tax board services for enhanced collection efforts.
5. Utilize escrow banking services including:
 - a. daily, weekly, and monthly reconciliation of funds received;
 - b. weekly verification and disbursement of refunds due to the public;
 - c. monthly disbursement of County and State taxes; and

- d. processing of insufficient funds received.
6. Inclusion of administrative citation processing services including:
 - a. data entry of manually-issued citations;
 - b. notice generating and sending;
 - c. inbound call recorded customer service;
 - d. adjudication services; and
 - e. franchise tax board placement.

Introducing a more automated citation and permit management system will also reduce City resources currently required for manual administration of these functions.

5.3.2.6 Angle Parking Conversion

Begin converting parallel parking to angled parking in areas with high parking demand and based on preliminary feasibility analysis summarized in this Specific Plan. As discussed in the “On-Street Angled Parking Survey” section the study’s analysis found that 220 on-street parking spaces could be added in just the 2 small surveyed areas, a net gain of 36%. Where street widths and travel patterns allow, conversion to angled parking is one of the most cost-effective ways to quickly increase the parking supply in high demand areas, can provide some traffic calming and traffic calming benefits, and implements some of the policy goals of the General Plan. The implementation plan is outlined in Figure 5-10. All the street blocks that were measured during the angled



Potential Roosevelt Avenue Reconfiguration

Figure 5-10: On-Street Angled Parking Conversion Plan

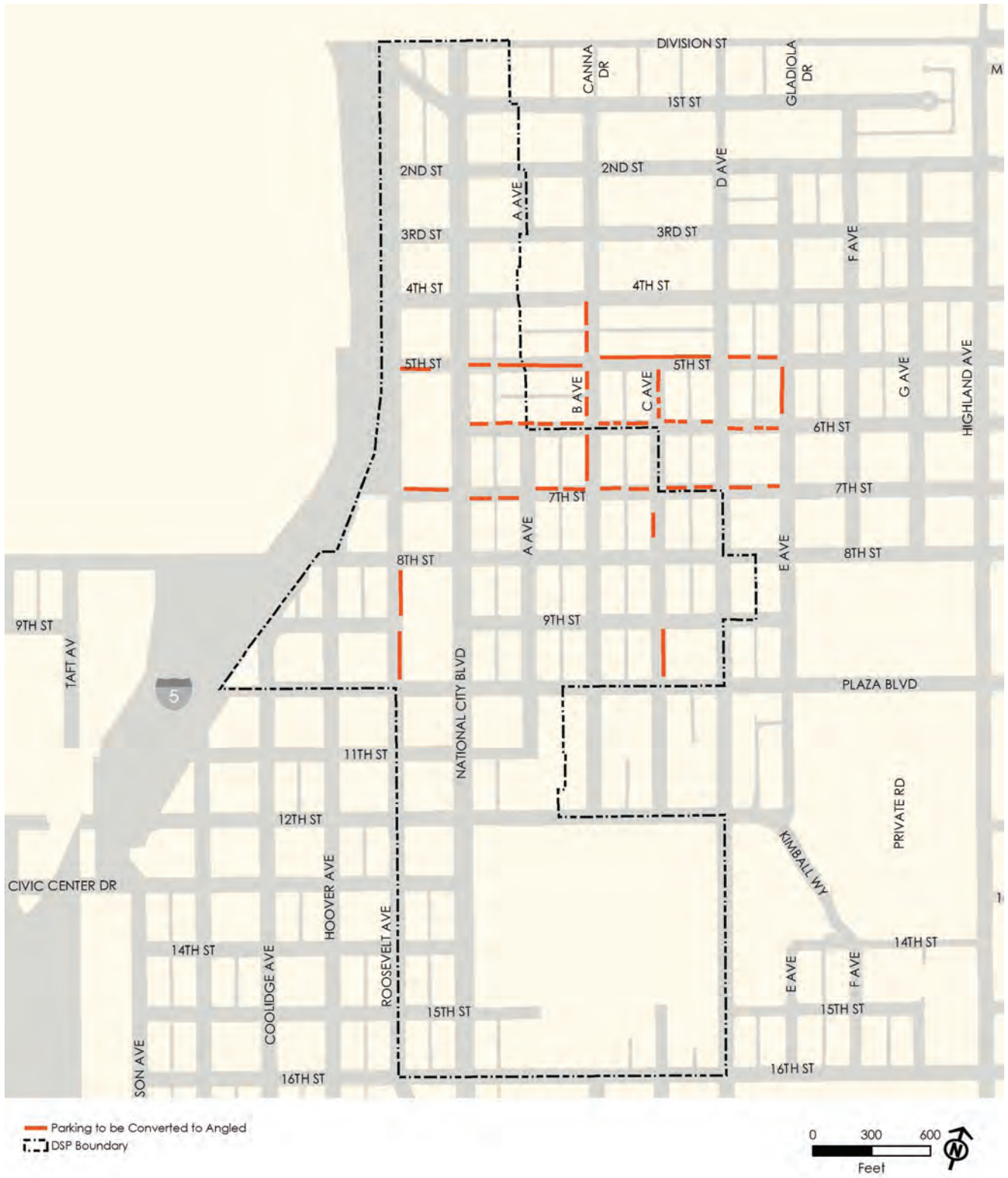

parking survey, as well as some additional locations that were identified as feasible, have been included in the angled parking conversion plan to maximize the on-street parking space inventory.

5.3.2.7 Restrictions and Fines

Review parking restrictions & fines to ensure they are both tailored to disincentive those violations that have the most negative impacts on the parking/transportation system (e.g. violation of time limits), residents' quality of life, and non-residents' visitor experience. Having the appropriate parking restrictions and violation fine amounts is important to ensure that the City can properly enforce on-street parking throughout the city based on the unique context and parking needs of different areas. Examples of potential priorities include:

- Time limit violations - Enforcing the time limits will ensure efficient turnover of vehicles parked in on-street spaces, especially within the downtown area.
- Parking in vehicle travel lanes, in bike lanes, or on sidewalks - These violations reduce the efficient and safe operation of National City's multimodal transportation system.
- Parking in designated red curb (no parking) or blue curb (accessible parking) zones - Parking

in red curb zones often blocks corner visibility and/or fire hydrants which creates safety issues. Fraudulent use of accessible parking spaces without proper authorization displayed inconveniences disabled motorists and is a violation of federal ADA (Americans with Disabilities Act) civil rights law.

- Safety or quality of life impacts - Restrictions related to recreational vehicle (RV) parking, overnight commercial vehicle parking, repairing and selling vehicles on the public streets should be enacted and/or consistently enforced in areas where these violations create safety concerns or generate complaints from residents or merchants in the vicinity.

A comparative analysis of National City's parking violation fee structure found that the fee amounts were generally lower than other communities. Table 5-9 shows the fee amounts for various parking violations assessed by National City and 10 other communities. A key finding was that National City's penalties are lower than the comparable cities in each category, with the exception of Handicap Parking. Because current fee amounts are so low, this represents an opportunity to strategically increase the fee amounts for violations that the City would most like to disincentive as described. For priority parking violations, fine amounts in National City could be increased by as much as 50%



Commercial Vehicles Parked Along Roosevelt Avenue

Table 5-8: Comparative Analysis of Parking Violation Fee Amounts

City	Double Parked	18" From Curb/Wrong Way	Handicap Parking Only	Expired Registration	No Plate	Blocking Sidewalk	72 Hour Storage on Public Street	Washing/Repairing on Street	Red/Yellow/White/Green Curb	Time Zone Violations
National City	\$25.00	\$25.00	\$330.00	\$30.00	\$30.00	\$25.00	\$50.00	\$35.00	\$35.00	\$25.00
Albuquerque	\$20.00	\$20.00	\$20.00	\$350.00	\$20.00	\$20.00	\$20 / 24 hrs	\$20.00	\$20.00	\$20.00
Anaheim	\$32.00	\$32.00	\$287.00	\$193.00	\$108.00	\$32.00	\$64.00	N/A	\$49 (r) \$34 (y,w,g)	\$34.00
Chula Vista	\$47.50	\$35.00	\$396.00	\$104.00	\$104.00	\$35.00	\$25.00	\$25.00	\$35.00	\$25.00
El Cajon	\$32.50	\$32.50	\$362.50	\$32.50	\$67.50	\$32.50	\$57.50	\$42.50	\$32.50 (y) \$42.50 (w,g,r)	\$32.50
La Mesa	\$42.50	\$42.50	\$348.00	\$57.50	\$32.50	\$42.50	\$57.50	\$57.50	\$57.50 (r) \$42.50 (y,w,g)	\$42.50
Long Beach	\$65.00	\$45.00	\$340.00	N/A	N/A	\$60.00	\$49.00	\$45.00	\$49.00	\$49.00
Oceanside	\$58.00	\$58.00	\$338.00	\$83.00	\$83.00	\$58.00	\$83.00	\$58.00	\$58.00	\$58.00
Salt Lake City	\$30.00	\$30.00	\$150.00	\$30.00	\$30.00	\$30.00	\$30 / 48 hrs	N/A	\$15 (g) \$30 (y,w,r)	\$15.00
San Diego	\$47.50	\$47.50	\$342.50	\$62.50	\$37.50	\$37.50	\$62.50	\$62.50	\$62.50	\$62.50
San Leandro	\$60.00	\$60.00	\$280.00	\$13.00	\$81.00	\$81.00	\$66.00	\$50.00	\$45.00	\$36.00

and would still be comparable with other cities in the region (e.g. La Mesa and Oceanside) while remaining lower than the City of San Diego.

It should be noted that the goal of increased fee amounts for parking violations is to promote the safe and efficient use of the transportation system generally and public parking assets specifically. Increasing revenue generation should not be the goal of increasing fee amounts; in fact, in a well-managed, customer-friendly parking system, revenue from parking violation fines should steadily decrease as reforms are implemented and remain at a consistently low level relative to other forms of parking revenues (priced parking revenue, in-lieu of parking fees, etc.).

Establish a Parking Bonus System for off-street parking and shared parking. It is suggested based on conversations with technical stakeholders, business/property owners, and the real estate community to a) ensure that parking needs are being met in the most efficient way possible and b) reduce barriers to redevelopment in mixed-use districts and transit corridors. Several new developments are currently planned in National City, and more development will inevitably occur to accommodate projected growth. As a result, the City is wisely taking a proactive approach to assessing future parking demand for new developments, including reforming off-street parking requirements in such a way to incentivize the rehabilitation of existing structures and infill redevelopment of smaller

parcels. This study recommends that parking demand projections be developed for every mixed-use district and transit corridor which are priority areas for where the City would like to direct new “smart growth” development.

The process of updating off-street parking requirements for mixed-use districts and transit corridors should be based on best practice research and modeling tools and should evaluate the feasibility of the following preliminary recommendations:

- Eliminate off-street parking requirements by right for use changes/intensification and for new development with staff-approved parking management plans that include (in order of priority) parking demand reduction strategies, shared parking, and/or off-site parking.
- For any uses where parking requirements are not eliminated, establish an in-lieu of parking impact fee to be paid for each required off-street parking space not constructed on-site or provided off-site. Use fee revenues to fund programs that (in order of priority) improve management of existing parking supply, reduce parking demand, and create new parking supply. An in-lieu parking fee will not only help National City attract the kind of low-traffic redevelopment and revitalization that it desires in older mixed-use districts and transit corridors but also generate funds to help improve parking conditions within the city.
- Convert existing off-street parking minimums to parking maximums. Allow development projects to provide more than the maximum allowed parking if all off-street parking provided is shared/public.
- Create other development incentives for projects that either reduce parking demand and/or create new shared/public parking supply, potentially including: density bonuses, reduction in vehicle trip impact fees, permit fee waivers, expedited entitlement approvals, and similar incentives that don't impact public health or safety.

One method of creating more innovative parking requirements is to offer a menu of options for a developer or landowner to agree to implement, in exchange for reductions in off-street parking requirements. Table 9 is an example of a system, where an applicant can select a variety of policy, program, land use, site plan and nearby site features. The applicant would receive a negotiated reduction in parking, based on the point system. This bonus system can be used either for a reduction in the amount of parking required for the desired number of units allowed on that site, or it can be used to add units without the need for parking, above the maximum units allowed under the adopted zoning and development requirements. Since this Plan is an alternative plan to the state mandated parking reductions in transit areas for affordable housing, it will still allow parking reductions but will require the developer or land owner to make commitments and engage in improvements that will help to assure there is a corresponding reduction in parking demand. This strategy would assume that the parking requirement as the base condition, be made the same in downtown as it is citywide. This will put more of an incentive on the applicant to agree to the parking improvement requirements of this bonus system and still allow the developer to save significant costs associated with parking development costs.

The bonus program has suggested a maximum of a 50% reduction in citywide parking standards. It has used a similar limit in a 50% increase in units above the normal maximum allowed. These restrictions are necessary to ensure that parking impacts to the residential and commercial areas in and around downtown are not negatively impacted by spill over parking. The rates could be adjusted in the future, once it has been verified that the bonus system is effectively lowering parking demand and is not impacting the public parking resources of the downtown. These preliminary recommendations will be vetted and refined during future stakeholder meetings including members of the real estate development community.

5.3.2.8 Roosevelt Avenue Reconfiguration

Changes to Roosevelt Avenue are proposed in the circulation chapter based on future development patterns, the opportunity to create a shuttle system, the development of a linear park and the improvement of the aesthetic edge to this portion of downtown. This parking chapter looks at Roosevelt Avenue for the potential of increased on-street parking, in a way that is more positive and efficient than the current situation.

Roosevelt Avenue currently allows for truck parking along the west side of the street, next to the I-5 freeway. Often, the entire length can be taken up by trucks parking overnight or throughout the day. There is no particular responsibility for National City to provide this truck parking. The truck parking has a number of problems associated with it other than taking up general purpose parking spaces. It blocks visibility into the city, results in trash accumulation, harbors some level of criminal activity and is a poor representation of what downtown National City is meant to portray.

The first action should be a change in the parking restrictions along this segment of roadway (from 7th Street to Main Street) that does not allow for oversized vehicle parking, as show in Figure 5-11. This short term solution is a cost effective way to resolve this problem, but a long term solution should strive to change the physical attributes of this area. Changes that will prevent truck parking would be more sustainable and would create less enforcement issues.

Table 5-10 shows the current parking resources found along the corridor, with three segments from Main to 7th Streets, 7th to 8th Streets and 8th Street to Plaza Boulevard. A total of 172 parking spaces exist, however, they are more than likely taken up by up to 30 trucks down the west side of the roadway. This leaves an average yield of 82 spaces along this corridor.

The conversion to parallel or angled parking are both shown in this section (see Figure 5-12 and Figure 5-13) as viable options. Table 5-11 shows a condition where both sides would remain parallel parking, with street trees being added at key lo-

cations in bulb-outs that will prevent truck parking. These tree bulb-outs will reduce the overall parking capacity, however, by eliminating the truck parking, a total of 134 spaces in the study area could be made available, where 82 currently exist. This option includes a multi-use path and shuttle route proposed for the west side of the street along with the addition of urban trees.

The conversion of the west side to angle parking in addition to keeping the east side as parallel parking is shown on Figure 5-12. This solution would produce a total of 162 parking spaces compared to the current 82 spaces. However, this solution does not provide a multi-use path and the shuttle would need to travel in the regular traffic lanes.

It should be noted that some level of grading and retaining wall construction would be necessary to make either of these options implementable. In addition, the existing above ground utilities would need to be moved underground in order for these options to work with current infrastructure. Though these elements may be expensive, they do provide a major improvement for this edge of downtown and provide mobility options through an urban trail with streetscape development all while increasing available on-street parking.

Figure 5-11: Oversized Vehicle Parking Prohibitions

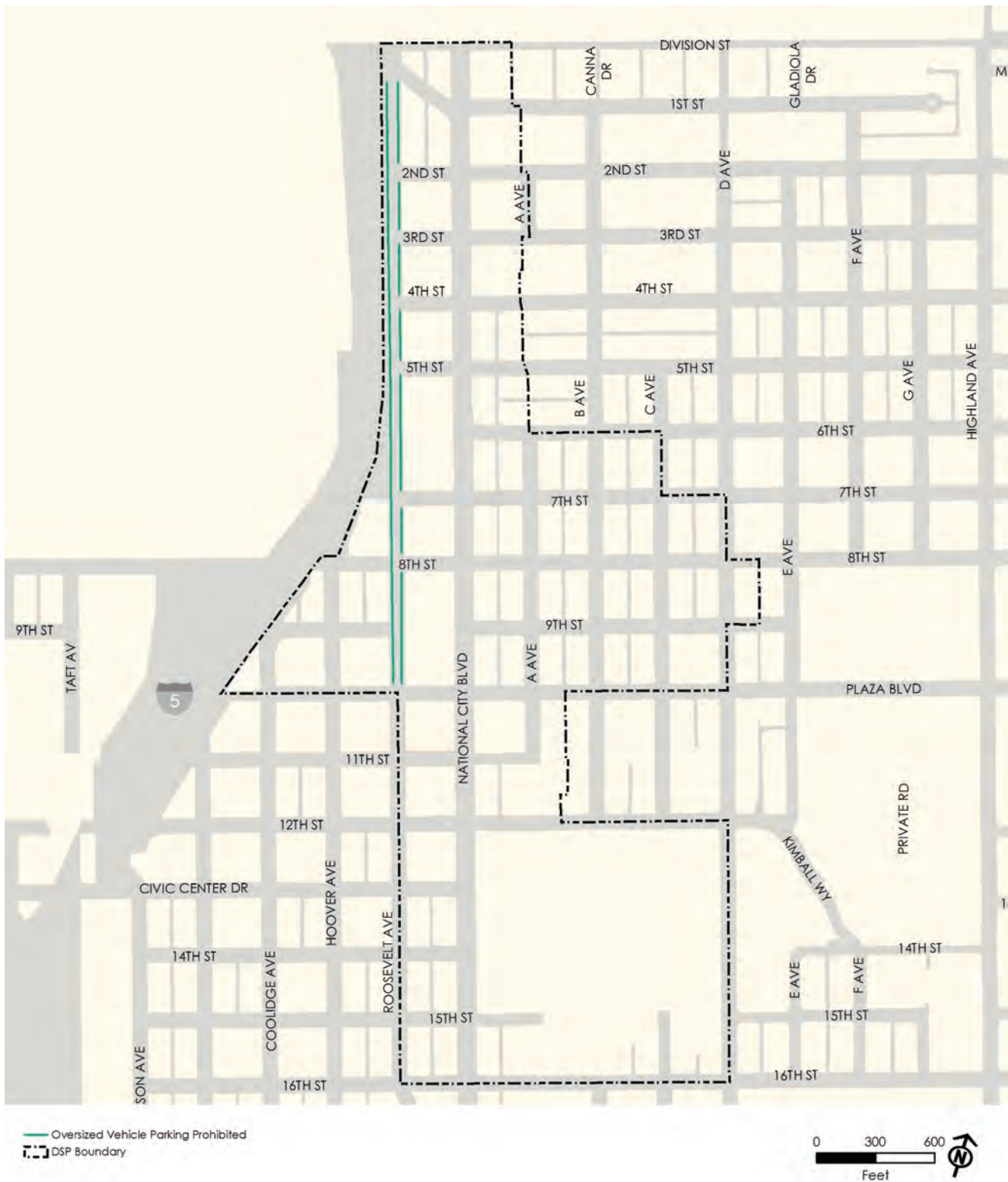

Figure 5-12: Roosevelt Avenue Angled Parking Option

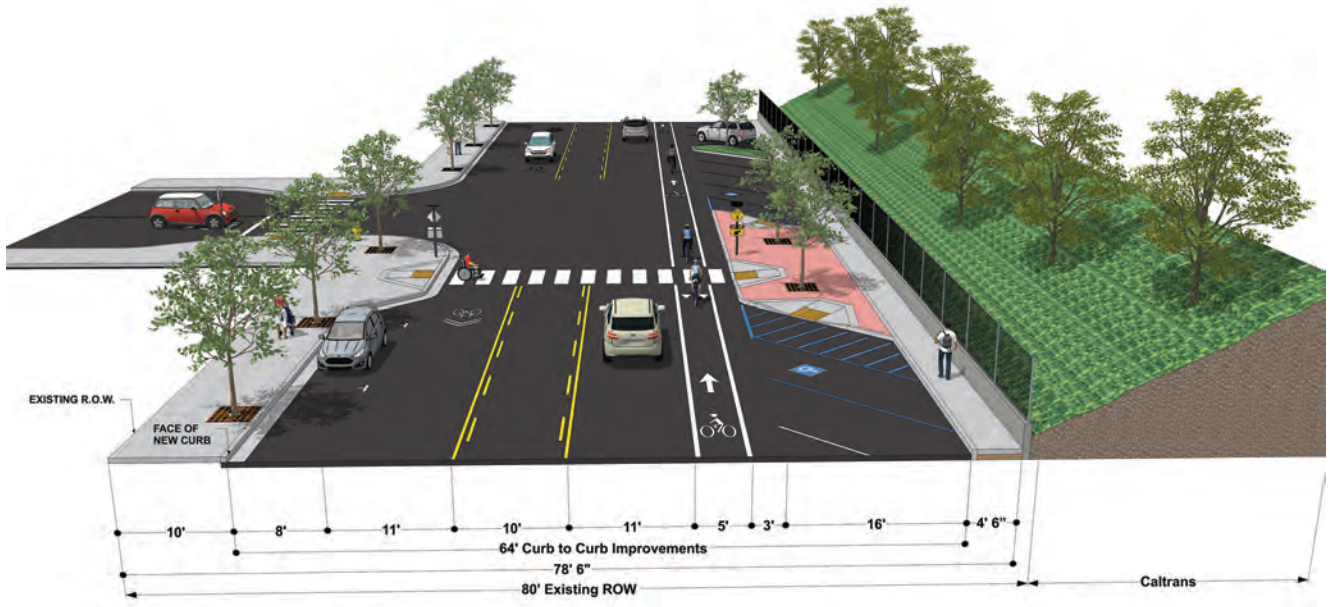

Figure 5-13: Roosevelt Avenue Parallel Parking and Multi-Use Path



Table 5-9: Roosevelt Existing Conditions

	Main St. to 7th	7th to 8th	8th to plaza
East Side Parallel	50	5	17
West Side Parallel	80	5	15
Existing Total Balance	130	10	32
			Grand Total 172
			Parking Taken up by Trucks (assume 30 trucks @ 60'= 90 automobile spaces) 90
			Likely auto parking currently available with truck parking impacts 82

Table 5-10: Future Conditions with Parallel Parking (Both Sides) and Multi-Use Path

	Main St. to 7th		7th to 8th		8th to plaza	
	Remaining	Proposed	Remaining	Proposed	Remaining	Proposed
East Side Parallel to Remain			7			
West Side Parallel to Remain	0		4		16	
East Side Parallel New		47				
West Side Parallel New		76				
East Side Angled New						31
West Side Angled New						
	0	123	11	0	16	31
New Balance		123		11		47
					Grand Total	134

Table 5-11: Future Conditions with West Side Angled Parking and East Side Parallel Parking

	Main St. to 7th		7th to 8th		8th to plaza	
	Remain	Prop.	Remain	Prop.	Remain	Prop.
East Side Parallel to Remain			7			
West Side Parallel to Remain	0		5		16	
East Side Parallel New		47				
West Side Parallel New						
East Side Angled New						31
West Side Angled New		103				
	0	150	12	0	16	31
New Balance		150		12		47
					Grand Total	162



Roosevelt Avenue Existing Conditions

5.3.2.9 Residential Permit Parking

Expand the residential permit parking zones where necessary to protect residential neighborhoods from anticipated parking spillover impacts, as shown in Figure 5-14. In order to help reduce parking spillover from future developments, the City should consider expansion of the existing residential parking permit program into the neighborhoods north and south of E. 8th Street. In addition, introducing on-street permits to allow carshare vehicles and employee vehicles to exceed parking time limits or other on-street parking restrictions should be considered. The City should begin transitioning to digital permitting with the use of LPR for the residential permit parking zones. A fully digital system will allow for more flexibility and efficient enforcement methods. The digital permits will be linked to license plate numbers. An online customer portal will allow residents to apply for a residential permit and upload supporting documents. Typically, residential permit parking programs also allow for a limited number of guest parking permits per household. It is important that adequate signage is posted throughout the residential permit parking zones to inform visitors of the rules.

5.3.2.10 Parking Transportation Demand Management

Downtown National City is well positioned to attract future development based on its proximity to key hubs in the region, bayfront location, and adjacency to transit. In addition, the market conditions are favorable to support smaller unit-sized apartments, condominiums and single-family homes to make housing more affordable and varied. The market trends for this portion of the San Diego region and for certain demographics, is an increase in urban living with mobility options other than driving. Technology is also a trend that is influencing parking supply and demand. Autonomous vehicles will likely start changing travel patterns, vehicle ownership and parking requirements over the next 5 to 10 years and should be taken into account when planning for the future.

This Specific Plan focuses future growth and public investment in policy and capital projects that support a "car light" lifestyle that in turn supports a more walkable and bikeable community as well.

The current parking standards for downtown National City are already transit supportive and are not considered to be excessive when compared to many other city's downtown areas. While some regions in the United State are becoming aggressive at lowering parking rates, this plan takes a slightly more conservative approach. Instead of just lowering rates to encourage more transit, biking and walking, this plan provides a bonus incentive program to investors, landowners and developers to consider. The primary focus of the bonus plan is to incentivize developers to make commitments and/or pay for certain improvements in exchange for lowered parking rates. This approach makes developers partners in improving the types of facilities and programs that can help to support mobility options and a car light lifestyle. Developer and City provided amenities and facilities will also help to attract people to live in the downtown area.

The Parking Transportation Demand Management (PTDM) offers choices to a developer that may be set up in a formal developer agreement (see Table 5-13). Some of the options will require designs and facilities integrated into project plans while others will require funding agreements to help support the City in its efforts to make physical changes to the circulation system and public spaces. In either case, the menu of options is only required if the developer wishes to reduce the the required parking and thus reduce the costs associated with structured or surface parking lot development. This proposed plan does function as a replacement for the State of California Government Code 65915 which mandates reductions in parking for projects qualifying for a density bonus and is located one-half mile from a transit stop. See the State of California Government Code 65915 for more details. Affordable housing units will be able to trigger some reductions in parking under this bonus system, but not without other commitments, which is allowed under the state laws. Finally, some level of funding is expected from developers

Figure 5-14: Expansion of Residential Permit Parking

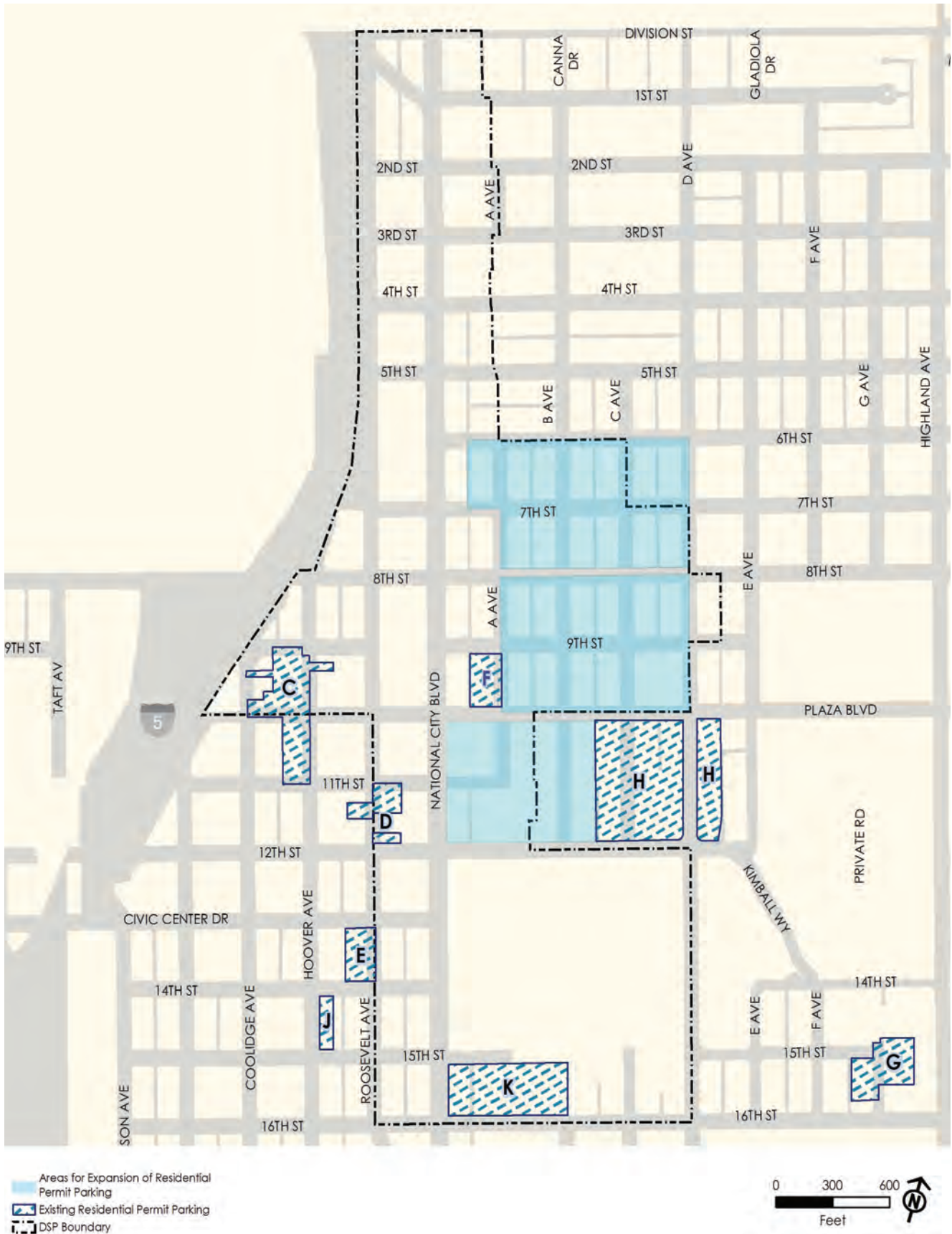

Table 5-12: Parking Transportation Demand Management Worksheet

PARKING TRANSPORTATION DEMAND MANAGEMENT
(Please fill in yellow cells only)

ENTER PROJECT NAME HERE		Very Effective		Effective		Partially Effective	
		Units	Points	Notes	Points	Notes	Points
City of National City- Downtown Specific Plan							
SITE DESIGN		Metrics to Use / Enter in Yellow Cells Only		1 Unit Point		1/2 Unit Point	
Access to garage by alleys that lowers on-street parking removals	Enter 3 on-street spaces saved by alley access						
Provide underground parking or street level structure fully screened / landscaped	Enter 1 for each face block screened						
Provide flex parking that can be converted later from parking to ground floor retail	Enter # of flex parking spaces						
Provide surface parking area that doubles as public realm space if not parked on	Enter # of convertible surface spaces						
Minimize curb cuts to protect on-street parking	Enter # of on-street spaces saved (2 per curb cut)						
For employment uses, provide a changing room / shower	Enter # of changing rooms						
Provide secure bike parking internal to building	Enter # of secured bike parking spaces						
Widen adjacent public walkways beyond 8' in total width	Enter # of feet above 8' for increased width						
Provide work lofts with flex space for "at-home" work or small business	Enter # of lofts with flex work space						
LAND USE / TENANT MIX							
Include mixed use for local serving retail & services in building	Enter a 1 for every 1,000 sf of services						
Include micro-units below 500 sf (gross including common areas)	Enter number of units below 500 sf						
Provide affordable housing with resale restrictions*	Enter # of affordable units						
Provide senior housing or assisted care housing	Enter # of sr. units						
PROGRAMMATIC							
Provide cash out (money back if parking not used) for owners, renters or tenants	Enter # of cash-out parking spaces offered						
Unbundle parking from leases or sales & require pay parking	Enter # of unbundled parking spaces offered						
Provide public use (free or pay) of unused parking resulting from cash out policy	Enter # of unbundled residential units						
Unbundle free parking for commercial leases	Enter # of unbundled tenant business units						
Arrange for shared parking agreements with on-site or near site providers	Enter # of off-site spaces in agreement						
Provide priority parking for certified vanpool or carpool users	Enter # of special spaces provided						
Provide reserved space for carshare	Enter # of carshare spaces provided						
Tenant provided with rent credit for each employee allowed to telework	Enter # of on-site jobs allowed to telework						
NEAR SITE FEATURES							
Help fund district parking conversions from parallel to angled parking	Enter # of spaces paid for (@\$1,000 per space)						
Provide a drop-off zone for Ridesharing such as Uber / Lyft / taxis	Enter # of drop off spaces						
Finance improvements for an enhanced transit stop	Enter # of transit stops @ 20k Commitment						
Provide public recharging facility	Enter # of public charging stations						
Provide carshare reserved spaces on street (such as Car2Go)	Enter # of reserved on-street spaces						
Provide small parking for NEV, motorcycles or scooters	Enter # of spaces with NEV counting as 3						
Provide additional off-site bike parking beyond on-site bike parking	Enter # of bike spaces						
FUNDING							
Provide membership in carsharing programs if available	Enter # of memberships offered @ \$100 per year						
Provide membership in bikesharing programs if available	Enter # of memberships offered @ \$50 per year						
Property manager to subsidize (75%) transit passes for one car tenants	Enter # of weekly transit passes offered						
Property management to subsidize (75%) transit for on-site employers	Enter # of weekly transit passes offered						
Property manager to subsidize (75%) passes for tenants to give to customers	Enter # of weekly transit passes offered						
Property manager to offer links to SANDAG rideshare / iCommuter / RideMatcher	Enter # 1 if offered						
Pay in-lieu fees for parking structure or lots	Enter # of in-lieu spaces paid for @ \$10k each						

Total Parking Bonus Points

GO UP WITH MORE UNITS WITH ZERO PARKING REQUIREMENTS

- 1) Total Voluntary Parking Bonus Points from Above **
- 2) Originally Proposed # of Units without Parking Bonus
- 3) Adopted Residential Parking Required
- 4) Calculated Residential Parking Rate
- 4) Adopted Non-residential Parking Required
- 5) Total Pre-bonus Parking Requirement
- 6) Maximum Bonus Units (50% of Proposed Units)
- 7) Total Number of Units with Bonus Points Applied
- 8) Calculated Increase in Units
- 9) Resulting Parking per Unit



OR

OR GO DOWN IN THE PARKING REQUIREMENT

- 10) Total Voluntary Parking Bonus Points from Above **
- 11) Originally Proposed # of Units without Parking Bonus
- 12) Maximum Bonus Units Allowed (50% of Proposed Units)
- 13) Bonus Points Converted to Units (Do Not Count Over Limit Above)
- 14) New Total Units using Bonus Units
- 15) Adopted Residential Parking Required for Base Condition
- 16) Calculated Parking per Unit Rates with Bonus
- 17) Calculated Decrease in Parking



ASSUMPTIONS

* State legislation requires parking reductions in transit areas, unless an alt. bonus program (such as this) is offered.

** The bonus program can not occur without the parking management district

*** Requires developer, prop. manager or owner to provide a PTDM report every 5 year

as part of exactions or to landowners property tax assessments to help fund the proposed downtown shuttle system. This on demand and scheduled electric vehicle system will need a steady funding source. Possible community facility development funding sources that apply an annual fee to property owners may be part of this funding stream.

The intent of the PTDM is to either lower the number of parking spaces that will be required of a new development or to allow the addition of more units without associated parking to be developed that may go beyond the current FAR, unit limits or height restrictions. This process will require a discretionary process that will need to be negotiated. Typically, in order to exceed entitlement limit adjustments, a public benefit is needed. The items from this bonus list would be part of those public benefit findings.

5.3.2.11 Paid Parking

The City should integrate parking equipment and infrastructure needs into the City's capital improvement planning/budgeting process to ensure appropriate resources are allocated on an ongoing basis for parking capital costs necessary to support an expanded comprehensive parking management program.

Maximizing parking utilization is a key component to a successful parking management program. Paid parking should be implemented where necessary to promote turnover and achieve availability targets, and the City should proceed with a paid parking pilot program. The locations for the installation of single space parking meters are illustrated in Figure 5-15. Paid parking should be implemented only after ensuring the appropriate resources are in place to provide consistent and effective enforcement, in order to ensure a successful pilot program. The parking meter pilot will provide the opportunity to vet the viability of paid parking and potential forecasted income. Based upon the pilot program results, the City could consider purchasing meters and potentially expanding the paid parking program.

A demand-responsive rate structure should be linked to average parking demand in each paid parking zone.

- Integrate on-street prices with off-street prices to incentivize parking in on-street spaces for shorter durations and parking in off-street spaces for longer durations (or in areas where on-street parking demand is high and/or supply is limited).
- Minimize the use of curb-side meter infrastructure through the use of single-space meters and/or mobile payment apps.
- Coordinate pricing technology with other parking management and enforcement technologies recommended in this Plan, including License Plate Recognition (LPR) enforcement, parking occupancy sensors, and real-time information on parking availability and prices.



Example of Single-Space Meter

Figure 5-15: Single Space Parking Meters and Time Restricted Parking

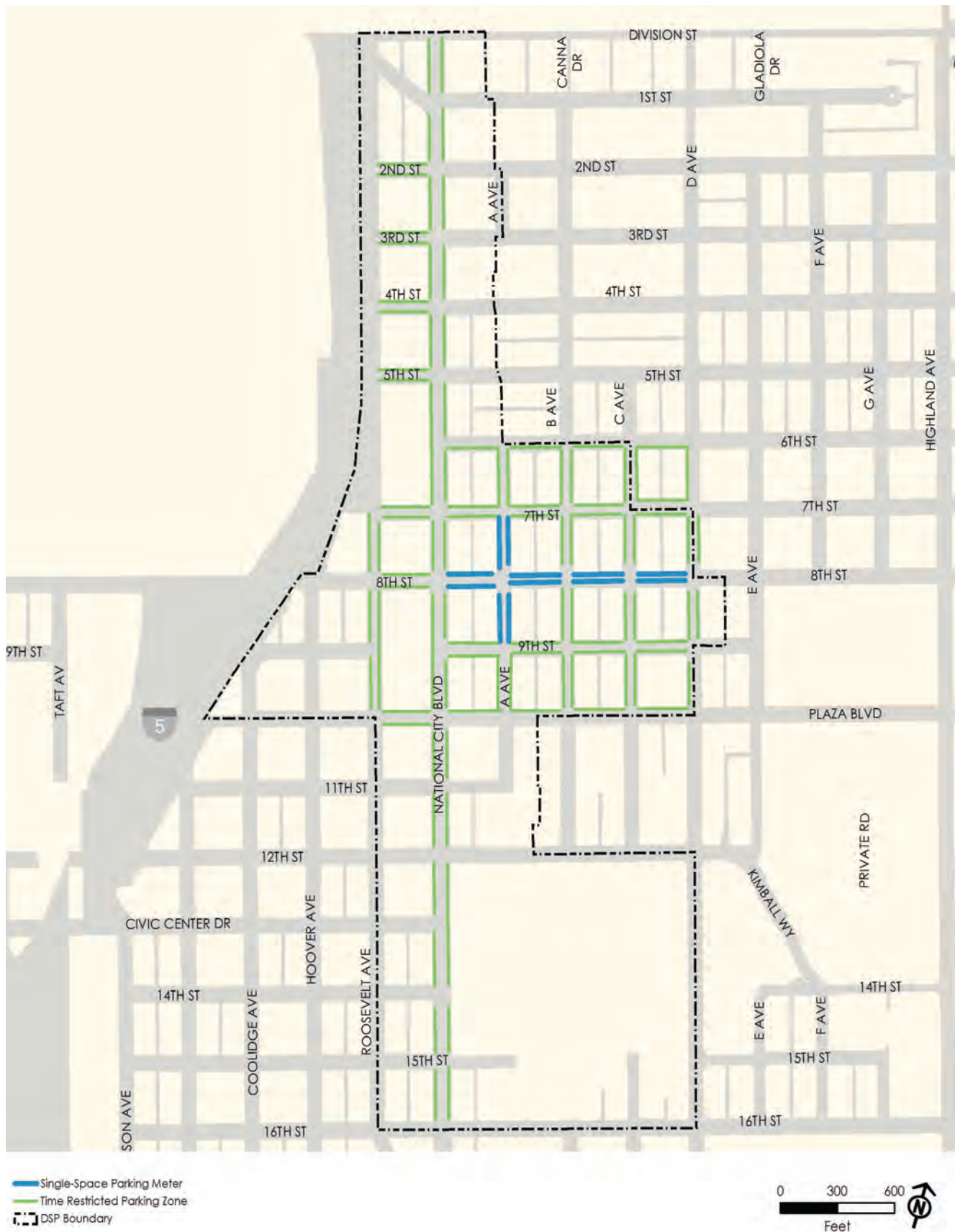

5.3.3 PHASE 2 (3-5 YEARS)

Implement active monitoring to review week day and weekend on- and off-street parking occupancy rates on at least an annual basis to determine any necessary adjustments to parking regulations or rates. It is the industry standard that occupancy should not exceed 85% ideally.

Complete the angled parking conversion downtown to maximize the available parking supply. This will help mitigate potential spillover parking issues due to increased development and decreased parking ratios.

Establish a new Mobility Manager staff position to Implement the Initial Phases of a Parking Benefit District and the Proposed Shuttle System. This position would be in the City and would focus on the creation and operation of an integrated Parking/Transportation Demand Management (PTDM) Program. Although the City already has some existing PTDM policies and programs, the creation of an expanded and strategically integrated program will be necessary to accommodate new growth while maintaining a high quality of life and business climate. The first step should be the establishment of a full-time, dedicated Mobility Manager staff position to:

- a) identify the most critical needs in conversation with community and technical stakeholders,
- b) create a workplan to provide strategic direction to guide future operations, including the introduction of programs such as a coordinated vanpool program, a comprehensive valet parking system, and provision of reduced-cost transit passes to residents and employees in high parking demand areas and
- c) initiated the parking benefit districts.

Some key functions of a Mobility Manager include:

- Serve as the liaison to community leaders to demonstrate the benefits of the program.
- Provide direct outreach to area employers and employment.

- Research and write grant applications for future funding of existing and expanded programs;
- Plan annual conference on issues relating to transportation and parking.
- Develop potential for future expansion of transit and multimodal travel options locally.
- Plan and coordinate promotional events and activities related to general public transportation.
- Make public presentations on the benefits of mobility management for the community.
- Build community networks to support a sustainable transportation system, including reduced parking demand, efficient use of existing parking supply, and the addition of new parking supply.

Figure 5-16 outlines the mid-term implementation plan for enforcement, future permit zones, and potential time limit expansions. The use of LPR for enforcement will increase program efficiency and effectiveness, which is reflected in the outlined beats. Beat 1 should have a defined cyclical route that allows for a minimum of 3-4 patrols per shift. Beats 2 and 3 are dependent upon the rules to be enforced. Once consistent enforcement is achieved during the short-term, the resulting occupancy rates will help determine whether a time limit expansion is necessary. This expansion will also be subject to the downtown development plan.

Establish a downtown Parking Benefit District (PBD) to manage existing parking supply as efficiently as possible, implement district-wide programs to reduce parking demand, and identify cost-effective opportunities to add new parking supply when district-wide occupancy thresholds are met. In a PBD on-street and off-street parking are managed as an integrated system, with as much parking as possible managed as shared/public parking, and parking revenue allocated to fund improvements (both parking and non-parking) in the district where the revenue is generated.

Figure 5-16: Phase 2 Implementation Plan



(Note: there should be continued conversion of angled parking spaces under Phase 2)

The concept of a PBD, whether public or private or both, can apply to the city's business district(s) and neighborhoods. The crucial factor for the success of any PBD is stakeholder engagement. When the City decides to implement this recommendation, a first step will be to engage community members, property/business owners, and the real estate community to inform the creation of a detailed plan for the establishment and long-term operation of a PBD. Instead of all revenue going to the General Fund, a parking benefit district can allow districts to keep some of the money for investment in new meters, increased enforcement, as well as other neighborhood projects. By setting up a dedicated local revenue stream, there will be more community support for paid parking. Over time, meter revenue will increase as local improvements continue to attract more visitors.



*National City Education Village Parking
on Roosevelt Avenue*

5.3.4 CASE STUDIES

5.3.4.1 Old Pasadena, CA

Old Pasadena installed meters in 1993 and established a commercial PBD district named Old Pasadena Parking Meter Zone (PMZ). The City was previously offering free on-street parking to customers, but decided to install meters in the district when an agreement was made with the surrounding businesses. The City provided assurance to the business about paid parking by promising that all parking revenue generated would stay in the Old Pasadena District and be used to fund strategies to enhance the amount of customer visits. The City also developed a board ran by business and property owners to oversee all decisions made within the PBD. Through Old Pasadena’s successful PMZ plan, the city generated \$1.5 million in revenue.



Parking Meter in Old Pasadena, CA

5.3.4.2 Portland, OR

In 1997, almost all of the on-street parking spaces were taken by employees working in downtown Portland, Oregon. In order to combat this issue, the City, district stakeholders, and local transit agency (TriMet) decided to create the Lloyd District Partnership Plan that involved the utilization of meters and 51 percent of generated funds to be dedicated to the board that ran the district. One of the main decisions made by the City was to invest in alternative transportation methods like building bicycle infrastructure, which increased transit use by 46 percent and bicycle use by 5 percent.



Lloyd District Bicycle Infrastructure Improvements

5.3.4.3 Austin, TX

Austin received a \$43,275 grant from the U.S. Environmental Protection Agency to transform the City’s unsustainable parking situation, and the City established the West Campus PBD. Meters were added into the district and 51 percent of the funds were dedicated to the West Campus District PBD. The remaining funds would be allocated to the City’s General Fund. Funds generated from this residential district average at about \$300,000 per year and are used to improve the availability of on-street parking, as well as, encouraging walking, transit use, and bicycling. Local improvements in the City of Austin involved fixing bike lanes, curb ramps, street trees, and sidewalks.



Improvements Made During the Pilot Parking Benefit District Program in West Campus

5.3.5 PHASE 3 (5-20 YEARS)

Add availability signage to improve wayfinding throughout downtown. The growth of a city's downtown is partially dependent on the capability of attracting outside visitors, and it is important that they can properly navigate and locate parking when visiting downtown for shopping, dining, or business. The clear communication of facility locations, space availability, time restrictions, and parking rates can help ensure that a city is offering an efficient and understandable parking system. It is important to avoid the perception that it is difficult to park downtown.

To install automated parking guidance signs (APGS), the City must have an accurate tool to count vehicles and provide accurate parking availability numbers. This dynamic signage allows the City to direct patrons towards underutilized parking locations. The APGS/wayfinding signage should indicate parking lot status (open/closed), space availability (full/available or the number of spaces available), event parking details (as applicable), alternative parking areas, and targeted messaging. Parking availability can also be linked to a variety of publicly available, free parking applications. The City may want to consider distributing the information for public access via an application program interface (API) in addition to transmitting the data to additional APGS signs placed at the primary entrances to the downtown, especially at freeway off-ramps and at major arterial roads. A typical APGS sign costs approximately \$10,000 per sign to purchase and install, with approximately \$1,000 per year for software licensing.

If the City wants to develop an integrated mobile application (provided by the APGS system provider), the City should estimate approximately \$5,000. The cost of the mobile application development varies depending on the type of information to be displayed, branding requirements, and additional features. There are also a number of existing, free parking availability and guidance applications, such as ParkMe and Parkopedia, that leverage available public parking information using their interactive

parking application. These systems have provided drivers with the ability to plan their parking before leaving their home. This can enable people to make more informed decisions about how to get to their destination, evaluate alternative modes of transit, and, if they choose to drive, reduce traffic congestion by letting drivers know where they will park. This methodology would allow the majority of patrons to prepare their direction of travel upon approach thereby possibly reducing the traffic flow impact, discouraging backups, and address maximum capacity concerns. This is often referred to the concept of "first mile/last mile," planning.

Establish in-lieu fees to incentivize development in downtown National City. A Parking In-Lieu Fee Program is a common strategy used throughout California municipalities to manage parking. Instead of requiring developers to provide all the spaces mandated by the City's zoning code, they will have the option to pay a set fee in place of some of the parking spaces. This is a voluntary option that will make it easier for projects to be developed in areas that have geographic constraints or financial shortcomings that would otherwise make parking requirements difficult to achieve. The Parking Bonus Worksheet (Table 9) recommends that the price per space be set at \$10,000.00. The revenue from parking in-lieu fees may be used to invest in parking program improvements, transit projects, or pedestrian infrastructure for example. A sample in-lieu of parking fee matrix is outlined in Appendix X.

Plan infrastructure for autonomous vehicles. Autonomous vehicles will change parking demands for cities in the future. While this is not an immediate concern, having foresight for technological developments will allow for a smoother transition for National City. Many vehicle companies are expected to release autonomous vehicles around the year 2020. Additionally, Uber is expected to be completely driverless by 2030 with the early adoption by fleet programs anticipated. Autonomous vehicles may eventually affect parking by making convenient parking less of a concern. Once vehicles can drop off passengers at their destination, it will be less important to have park-

ing within the downtown core. This will increase the need for safe and efficient drop-off locations, and it will make building parking on the outer-ring of downtown more appealing and cost-effective. Vehicles may also have the ability to park in multiple rows, one behind the other with the ability to move when needed. This is a more efficient use of space and vehicles will have a smaller footprint in cities. A product of autonomous vehicles and the new approach to parking would likely include a reduction in the traffic congestion caused by drivers looking for parking spaces. This would ultimately make traveling downtown quicker and more appealing as parking would no longer be a major concern for downtown businesses.

These aspects of autonomous vehicles can be kept in mind when planning for the future of National City, but there will likely be a long enough timeframe to make the adjustments and retrofits to land use and parking as they become necessary. While it is never too early to begin planning for future transportation technology, in the case of autonomous vehicles there are many factors that must first be addressed by the transportation industry that include, but are not limited to, legislative requirements, safety standards, testing, cyber security, and enforcement before autonomous vehicle adoption will begin in the United States. The current California legislation and Department of Motor Vehicle (DMV) requirements govern the testing of autonomous vehicles on public roads. While 15 companies retain permits to test, the CA DMV regulations are considered prohibitive and the regulations clearly indicate that a driver must be ready to take control of the steering wheel at all times.³ While the restrictions are limiting, it is anticipated that rideshare programs, like Uber and Lyft, will likely be the early adopters of autonomous vehicles.

Set up a framework on a negotiation process for off-street shared/public parking agreements in areas with high parking demand. This process would be between owners of privately-operated off-street parking facilities and property owners and applicants for new developments. It should

be based on the Study's preliminary feasibility analysis summarized in this Plan. Shared parking means that parking spaces are shared by more than one user, which allows parking facilities to be used more efficiently. Shared parking takes advantage of the fact that most parking spaces are only used part-time by a particular motorist or group, and many parking facilities have a significant portion of unused spaces, with utilization patterns that follow predictable daily, weekly, and annual cycles. Shared parking between multiple land uses is an effective way to reduce the amount of space devoted to parking and reduce parking burdens on neighborhood streets. Efficient shared/public parking can also allow off-street parking requirements for new development to be reduced significantly.

A total of twenty-four (24) private parking lots were identified in the downtown area that contained twenty (20) or more parking spaces and where it appeared that shared/public parking could potentially be established in partnership between the City and the private property owner. Of these, three private parking lots were determined to be infeasible upon first inspection. However, as shown in Figure 5-2 and Table 5-5, a number of these private parking lots are located close to retail and restaurants, making them ideal candidates for shared/public parking programs. For example, the Bank of America and Union Bank lots (in particular) are ideal candidates. Between these two lots, an estimated 88 additional spaces could be added to the downtown parking inventory. Banks make an ideal partner for shared/public parking agreements due to their almost exclusive daytime and weekday parking demands (bank parking lots generally go unused during evenings and the majority of weekends). It is very common to see banks in other cities participate in shared/public parking programs. Another private parking facility of note is Southwest Community College lot located on Roosevelt Avenue south of 8th Street. This parking lot was identified as the largest in the Planning Area with an estimated 435 parking spaces, which is approximately ten times larger than any other parking lot observed in the Planning Area.

Figure 5-17: Phase 3 Implementation Plan

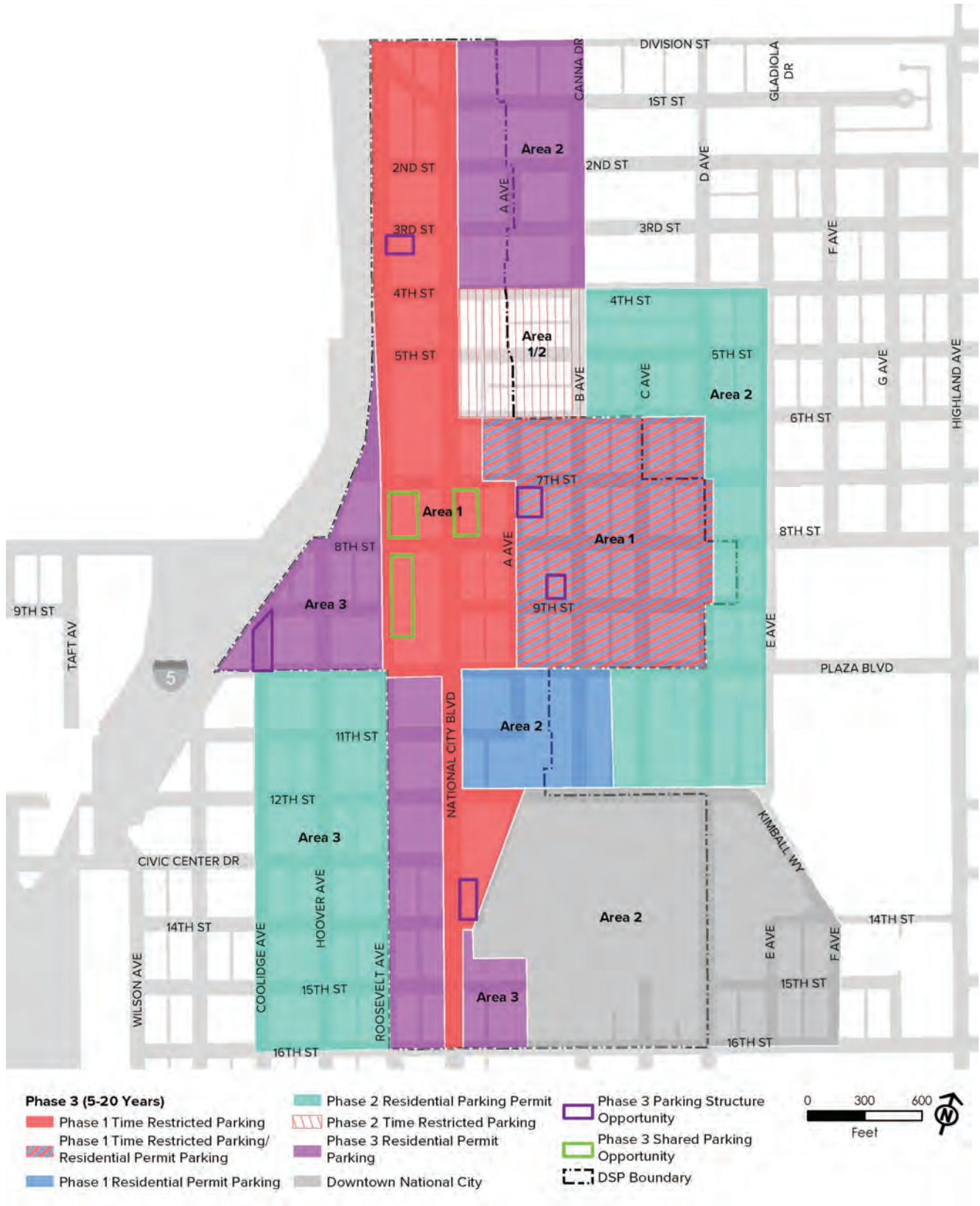

For example, the Bank of America and Union Bank lots (in particular) are ideal candidates. Between these two lots, an estimated 88 additional spaces could be added to the downtown parking inventory. Banks make an ideal partner for shared/public parking agreements due to their almost exclusive daytime and weekday parking demands (bank parking lots generally go unused during evenings and the majority of weekends). It is very common to see banks in other cities participate in shared/public parking programs. Another private parking facility of note is Southwest Community College lot located on Roosevelt Avenue south of 8th Street. This parking lot was identified as the largest in the study area with an estimated 435 parking spaces, which is approximately ten times larger than any other parking lot observed in the study area.

If the City wishes to utilize shared parking a number of considerations must be evaluated. These include:

- Term and extension of agreement
- Use of facilities
- Maintenance (responsible parties)
- Operations (responsible parties, revenue allocation, customer service, etc.)
- Utilities and taxes
- Signage
- Termination (cancellation and other considerations)
- The reputation/image of the City
- Regulatory & minimum design standards (zoning)
- Leases
- Parking competition (free adjacent parking);
- Staffing/capacity
- Insurance and liability

Invest revenue into parking & transportation improvements. When the In-lieu fee program starts to collect funding, it must be implemented in a timely manner to ensure that parking impacts do not occur. This could be planned for by the pur-

chase of surface parking lots that could later be transitioned into parking structures. Possible parking structure locations have been conceptualized on Figure 5-17. Partnerships with private developers, parking operators and property managers that have excess space in their garages due to parking cash out and unbundling programs, should all be part of the joint agreements and in-lieu fee program, and in the development of these publicly available parking resources.

Figure 5-17 outlines the long-term implementation plan for enforcement beats, permit districts, and a potential paid parking zone. Based on continuous occupancy monitoring, the City should determine what adjustments are necessary to achieve the City's goals and objectives as National City continues to grow and develop.

Notes

- ¹ While section 18.45.090 of the Municipal Code discussed accessible parking for disabled persons, there is no mention of denoting accessible on-street parking with blue painted curbs. Instead, the section only discusses requirements for accessible off-street parking spaces for disabled persons.
- ² The feasibility assessment of this potential is included in the Recommendations section of this Plan.
- ³ Los Angeles Times, California's proposed DMV rules for driverless cars could change in the wake of federal guidelines, Samantha Masunnaga, September 20, 2016

Page intentionally left blank



6

**DEVELOPMENT REVIEW
PROCESS**

6.1 APPLICATION

As part of the Development Review Process, all projects in the Planning Area involving new construction or the revitalization/rehabilitation of existing buildings or structures shall submit an Application for Consistency Review to be evaluated and processed by for the consideration of approval of City staff and in some cases by the City Council. All applications must provide the following information:

1. Identification of the Developer, Project Architect(s), and other members of the development team or consultants who would be responsible for implementing the proposed project (name of individual, firm address, telephone number, fax number, and e-mail address).
2. A completed and detailed narrative “Project Description” of the proposed project, including an explanation of how the proposed project complies with the Project Development Findings, individually addressing each finding.
3. Site Plan, drawn to scale, including all adjoining street/public improvements.
4. Floor Plans of all levels.
5. Exterior Elevations of all sides.
6. Cross Sections (minimum of two).
7. Parking Plan.
8. Preliminary Landscape Plan.
9. Colored Renderings.
10. Materials Sample Board.
11. Project Pro-Forma.
12. Twenty (20) copies of all drawings.
13. Electronic File of all exhibits.

6.2 PROJECT DEVELOPMENT FINDINGS

All proposed projects shall comply with the following policies:

1. Comply with the Specific Plan – The project complies with all of the requirements and standards of the Specific Plan.
2. Create a Place for People – The project enhances the pedestrian experience with attractive and distinctive design and amenities.
3. Enrich the Existing – The project enriches the qualities of the existing downtown by exhibiting a distinctive design that arises from and complements its setting, including the scale of the downtown, the block, and the street.
4. Make Connections – The project is integrated physically and visually with its surroundings by exhibiting attention to how to get around by foot, bicycle, public transportation, and the car – in that order.
5. Work with the Landscape – The project strikes a balance between the natural and man-made environment and utilizes each site’s intrinsic resources – the climate, landform, landscape, and ecology to maximize energy conservation and create distinctive amenities.
6. Mix Uses and Forms – The project weaves together different building forms, uses, textures, and densities.
7. Design for Change – The project is designed for energy and resource efficiency, creating flexibility in the use of property, public spaces (including the sidewalk), and the service infrastructure, and introduces or acknowledges through design new approaches to transportation, traffic management, and parking.

6.3 LAND USE REGULATIONS AND DEVELOPMENT STANDARDS

All projects must be in conformance with the regulations, development standards, and policies of the Municipal Code, the General Plan, and the Specific Plan.

6.4 CRITERIA FOR EXEMPTION FROM THE DEVELOPMENT STANDARDS

The City Council may consider and approve an exemption from the development standards based on one (1) of the following findings:

1. The project includes a significant public amenity that would otherwise not be required, including more than fifteen (15%) percent of affordable housing units or commercial rental space that is twenty-five (25%) percent below the market rate; or
2. The project makes a significant contribution to off-site public space in downtown National City, such as street improvements, public plazas, public park improvements and other improvements that are called for in the Specific Plan.

6.5 LEVELS OF REVIEW

6.5.1 MINISTERIAL REVIEW

To accommodate expedited review, urban infill projects that are in compliance with the Specific Plan, General Plan, Municipal Code, and any other applicable polices and codes, may be able to go through a ministerial review process. The descriptions below explain the requirements for a Level One ministerial review process (Figure 6-1 and Figure 6-2).

6.5.1.1 Level 1

The proposed project must meet the following:

1. Meets all applicable General Plan, Specific Plan, and Municipal Code codes and policies.
2. No request for variance or deviation.

Review process

1. The applicant submits the Application for Consistency Review and required plans, reports, and information.
2. The application and plans will be reviewed by departmental staff to determine if the project is consistent with all of the development standards and appropriate design guidelines. If deemed that the project is consistent, then the project may be submitted for building permits.



Figure 6-1: Planning Process Flow Chart

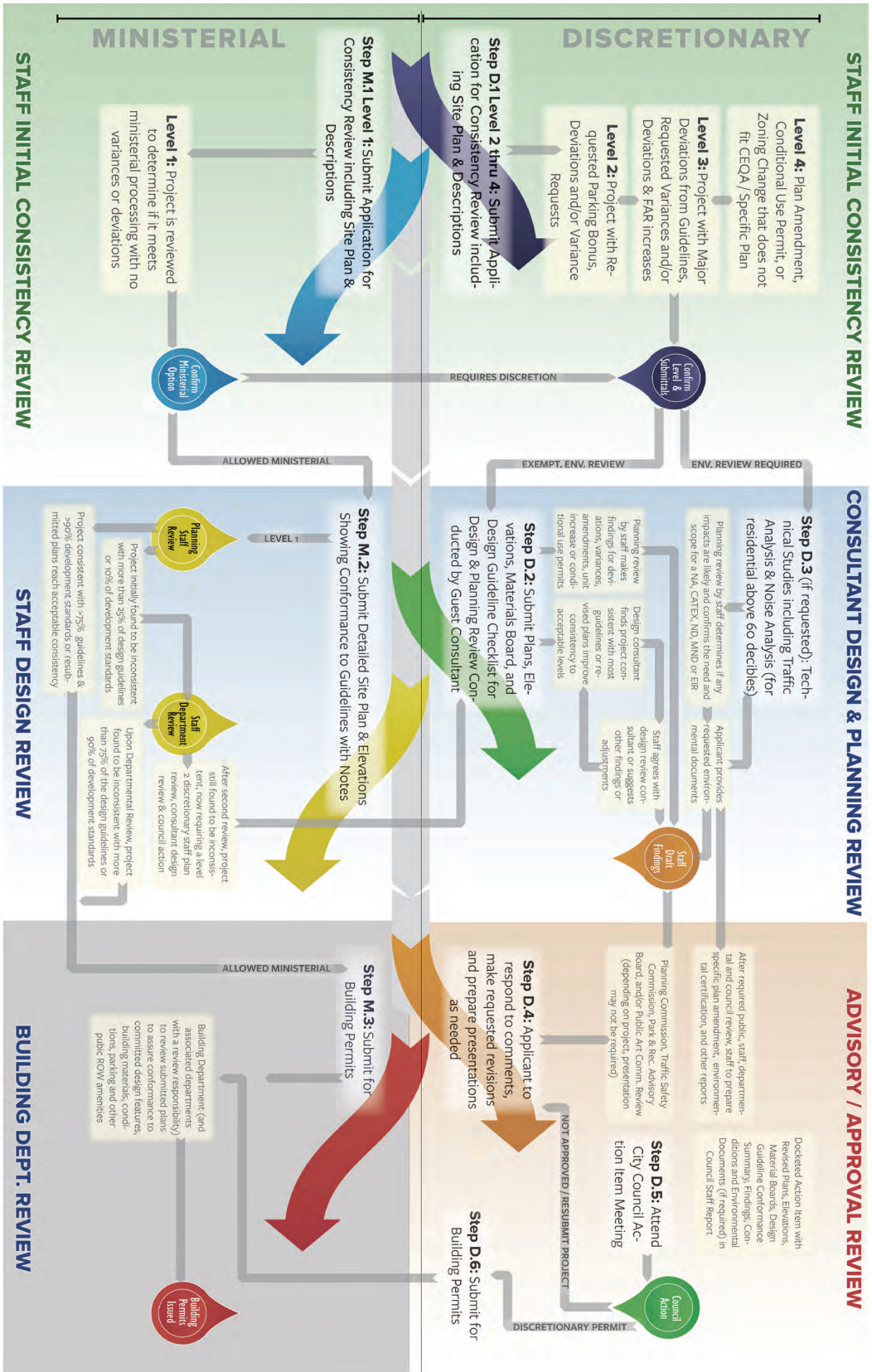
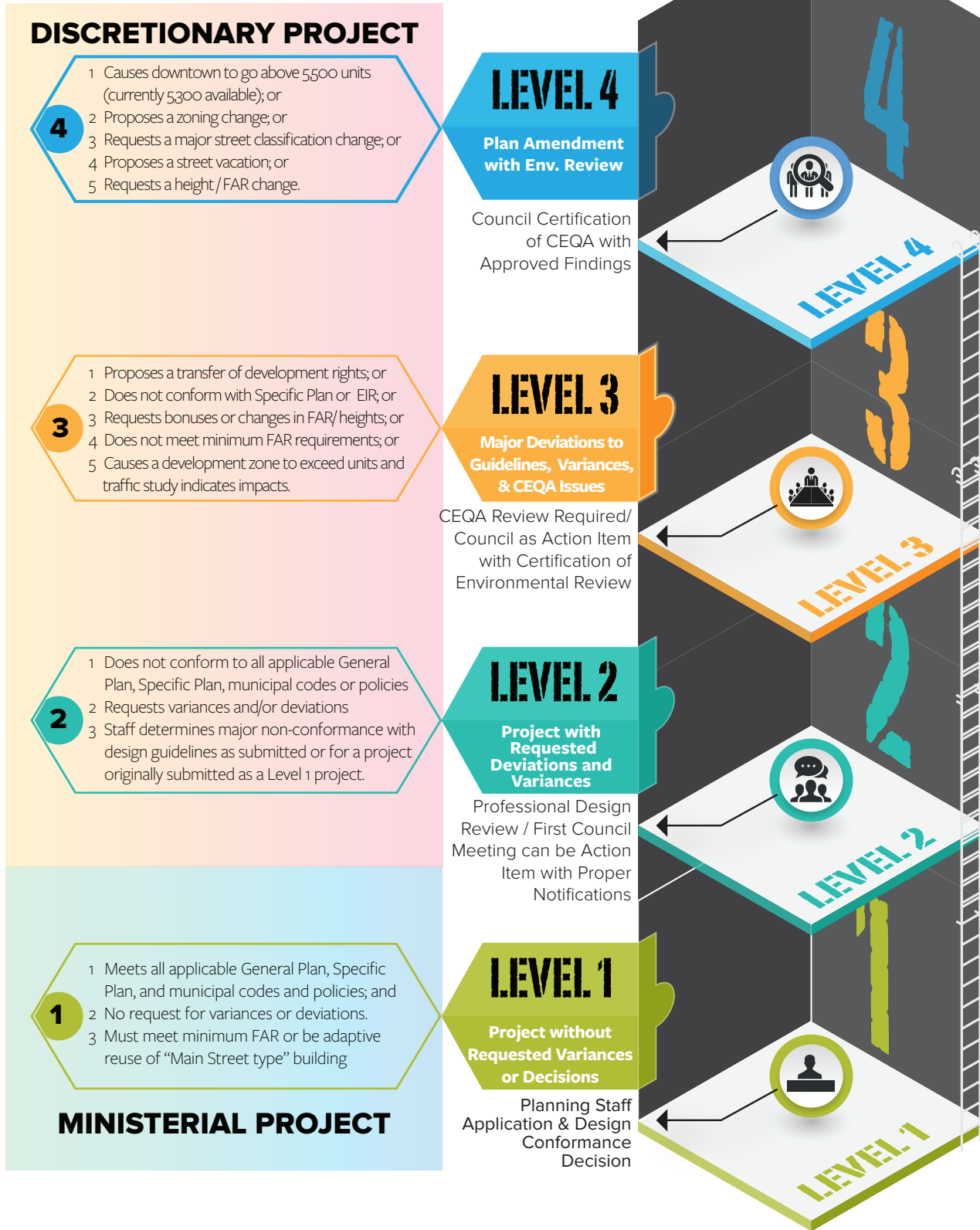

Figure 6-2: Project Levels and Review Process



6.5.2 DISCRETIONARY REVIEW

For proposed projects not meeting the requirements of the ministerial review, a discretionary level of review is required. The descriptions below describe the requirements for a Level Two, Three and Four discretionary review process. Please see Figure 6-1 and Figure 6-2 for additional clarification.

6.5.2.1 Level 2

If the proposed project meets the following, then it is a level 2 review:

1. Does not conform to all applicable General Plan, Specific Plan, and Municipal Code requirements; or
2. Is determined by staff that there are major issues to guidelines conformance of a Level 1 project; or
3. The project is requiring variances and/or deviations.

Review process

1. The applicant submits the Application for Consistency Review and required plans, reports, and information.
2. The application and plans will be reviewed by departmental staff and by a design consultant to determine if the project is consistent with all of the development standards and appropriate design guidelines. Multiple review cycles may be needed.
3. Once all issues have been resolved and the plans/reports are acceptable to staff and the design consultant, the project may then be presented to the Planning Commission, Traffic and Safety Commission, Park and Recreation Advisory Board, and/or Public Art Committee (depending on the project, a presentation may not be required).
4. After presenting to the various commissions/boards above, the project will then go to the City Council as an action item to approve or deny.

5. If approved, the project is then eligible to be processed for building permits.

6.5.2.2 Level 3

If the project proposes the following, then it is a level 3 review:

1. Transfer of Development Rights; or
2. Is not in conformance with the Specific Plan or EIR; or
3. Requests bonuses or changes in FAR/heights resulting in a 50 percent increase in entitled size; or
4. Causes a development zone to exceed units and traffic study indicates impacts.

Review process

1. The applicant submits the Application for Consistency Review and required plans, reports, and information.
2. The application and plans will be reviewed by departmental staff and by a design consultant to determine if the project is consistent with all of the development standards and appropriate design guidelines. Multiple review cycles may be needed.
3. Technical studies, if requested, such as a traffic analysis and/or noise analysis, to be submitted and reviewed by staff.
4. Staff determines if any impacts are likely and confirms the need and scope for the appropriate environmental document.
5. Once all issues have been resolved and the plans/reports/environmental document are acceptable to staff and the design consultant, the project may then be presented to the Planning Commission, Traffic and Safety Commission, Park and Recreation Advisory Board, and/or Public Art Committee (depending on the project, a presentation may not be required).
6. After presenting to the various commissions/boards above, the project will then go to the City Council as an action item to approve or deny.

7. If approved, the project is then eligible to be processed for building permits.

6.5.2.3 Level 4

If the project proposes the following, then it is a level 4 review:

1. Causes downtown to go above 5,500 units (5,300 available at the time of the approval of the Specific Plan); or
2. Proposes a zoning change; or
3. Requests a major street classification change; or
4. Proposes a street vacation; or
5. Proposes a height/FAR deviation in a transition area.

Review process

1. The applicant submits the Application for Consistency Review and required plans, reports, and information.
2. The application and plans will be reviewed by departmental staff and by a design consultant to determine if the project is consistent with all of the development standards and appropriate design guidelines. Multiple review cycles may be needed.
3. Technical studies, if requested, such as a traffic analysis and/or noise analysis, to be submitted and reviewed by staff.
4. Staff determines if any impacts are likely and confirms the need and scope for the appropriate environmental document.
5. Once all issues have been resolved and the plans/reports/environmental document are acceptable to staff and the design consultant, the project may then be presented to the Planning Commission, Traffic and Safety Commission, Park and Recreation Advisory Board, and/or Public Art Committee (depending on the project, a presentation may not be required).

6. After presenting to the various commissions/boards above, the project will then go to the City Council as an action item to approve or deny.

7. If approved, the project is then eligible to be processed for building permits.

6.6 ENVIRONMENTAL REVIEW

The Environmental Impact Report (EIR) that was prepared and certified by the former Community Development Commission addressed, as thoroughly as possible and without speculation, the potential environmental impacts that could be expected to occur with the implementation of the Specific Plan based on the information available at the time. The EIR for the Specific Plan has been prepared with the intent that, if future projects comply with the development standards provided in the Specific Plan, subsequent environmental analysis pursuant to the requirements of the California Environmental Quality Act (CEQA) will not be required. For all projects that are found to be consistent with both the Specific Plan and the EIR, a Notice of Previous Environmental Determination pursuant to the requirement of CEQA will be prepared. Likewise, if any future projects do not comply with the Specific Plan or the EIR, subsequent environmental analysis in the form of an Addendum to the EIR will be required pursuant to CEQA in conjunction with the approval process.

6.7 CONSISTENCY REPORT

Upon the submittal of an application of a proposed project, the City staff shall thoroughly evaluate the proposed project and prepare a Consistency Report. Once the Consistency Report has been completed, the City staff shall schedule the proposed project for a Public Hearing to be conducted by the City Council, unless the requirements listed in Figure 6-1 are met.

6.8 NOTICE OF PUBLIC HEARING

Upon the completion of the Consistency Report, the City staff shall publish a Public Hearing Notice at least ten (10) days prior to the date of the Public Hearing to be conducted by the City Council.

6.9 CITY COUNCIL ACTION

The City Council shall conduct the duly advertised Public Hearing for the proposed project in order to review and consider the Consistency Report and to receive public testimony. Upon the conclusion of the Public Hearing, the City Council shall adopt a Resolution of its action on the proposed project.





7

URBAN DESIGN GUIDELINES

7.1 URBAN DESIGN GUIDELINES

Urban design draws together the many strands of planning and design, including place-making, environmental sustainability, social equity and economic vitality. Urban design can help to create places of beauty and distinct identity. Urban design is derived from related professional practices such as site planning, transportation planning, architecture, landscape architecture and engineering. In the past 50 years, southern California has seen very extensive urban development and redevelopment. While there are exceptions, a great deal of this development is lacking in creating a “sense of place”. At worst, the results have been uninspiring, unpleasant, and has created environments that are dominated by traffic. The fine grain of the historic urban fabric of National City was diminished in the past through the process of suburban development patterns and lack of investment that brings along good design and high quality materials.

The primary purpose of Urban Design Guidelines is to equip project applicants, decision-making bodies, investors, and interested citizens with guidance on achieving high quality urban design in redeveloping and restoring the downtown.

7.2 URBAN DESIGN FRAMEWORK

This chapter provides guidelines that support broader development and investment goals of the Planning Area. All projects built in downtown and all property that is improved or enhanced, needs to contribute to the quality of the downtown experience and support economic land value increases, that will in turn increase private investments and demand for housing and businesses.

These guidelines are not standards that must be met with strict adherence. They are guideline topics that must be considered by a landowner, applicant or developer. Since most projects will require Council discretionary approval, and applicant is expected to address all guidelines that apply to the project’s location and building type. How well a project meets the goals of these urban design

guidelines will be considered as part of this discretionary review process. Applications will be used to discuss all relevant guidelines and responses on these applications will be used to evaluate a projects conformance to the overall goals of the downtown built environment. When variances, deviations and bonus programs are being sought, the likely benefits and qualities that the community might receive from the development will be considered for public benefit findings. Flexibility will be possible and creativity encouraged. However, all relevant topic areas must be addressed by all projects with varying degrees of conformance depending on the size and location of the project.

7.3 URBAN DESIGN GOALS

The goals of these guidelines are to provide direction to property owners, developers, consultants and business owners as to how the physical environment can be changed in a manner that will benefit all those that live, work, play, learn and invest in downtown properties. The intent is to not stifle creativity of talented consultants or to constrain a property owner with expensive treatments that will make investment difficult or to dictate styles or architectural themes. The intent is to provide guidance for planning, designing, and engineering physical changes in a way that will lift the impression of downtown National City as a positive place to be. The City has taken the first step in changing the downtown through public investments in streets and other infrastructure. The second step is to assure consistency and creativity of new elements that will build on these previous accomplishments. Guidelines should help to transform downtown while at the same time recognize those elements that work well. The guidelines should help the community move to an end state condition that will benefit the entire downtown as well as the City of National City and the region.

7.3.1 OVERALL URBAN FORM GOAL

All built improvements on private properties that interface with public space and right-of-way, are expected to relate to the following goal for downtown:

Downtown will become an organized and vibrant community with buildings and structures that support a mixed-use area and are oriented to downtown businesses, offices, institutions and public spaces. Buildings themselves should have a human scale at street level and include well-designed elevations that have high quality materials at lower levels that face public streets. Upper levels should provide compatible materials that relate to the street level design palette, and should include a form that is creative while still being related to local context, character, materials and scales of the surrounding neighborhoods. Consideration of transitions to lower density use and residential land uses is also essential in areas near lower density neighborhoods.

7.3.2 OVERALL PUBLIC REALM GOAL

The responsibility of improving street right-of-way will be placed upon the adjacent owner that has an application in for new or expanded development. In some cases, public investments have already occurred or will occur along different streets. Gaps in these improvements or removal of previous improvements will be required to be added or replaced by the applicant.

All public or private improvements within the public right of way or on public lands, are required to relate to the following end state goal for downtown:

Public spaces in the downtown will have achieved a harmonious and organized look that provides for consistency of the downtown area while at the same time emphasizes different downtown districts and functions. Improvements will have increased the comfort and safety of users of the right of way (or public lands) and will have contributed to wayfinding and expressions of local culture, history, art and district themes. Public activity will have been encouraged in this zone and the interface between private development and the public realm, will include public and semi-public spaces and facilities that encourage the activation of the space.

7.3.3 HUMAN SCALE FACTORS

In order to support a positive urban environment, buildings must visually relate to the street at a pedestrian scale. Buildings in the grid must be designed with sufficient attention to scale and detail that the pedestrian's sense of discovery is renewed with each viewing. Creating a human scale usually requires reducing the apparent size, bulk, scale and height of buildings, so that they do not overwhelm pedestrians. There are many architectural and design techniques that can achieve or convey a sense of a human scale.

Although the methods outlined in this chapter are encouraged, other approaches will be considered acceptable if they achieve the same objectives.

7.3.3.1 Human Scale Factors Guidelines

New developments should demonstrate consideration of building composition and detailing with the goal of achieving a human scale environment. This may be shown through elevation drawings, models or other graphic communications. As a general rule, views of the proposed project should be shown from public areas (e.g. streets and sidewalks).

- A.** The building base should visually anchor the building, establishing a strong connection to the ground and the site.
- B.** The base of the building should appear more massive than the upper stories.
- C.** Building details and the public art elements are encouraged to provide visual interest and a sense of delight and discovery.
- D.** Details should be comprehensible to passing pedestrians and proportionate to the scale of the building.
- E.** The upper stories of the building shall exhibit a lighter character than the base.
- F.** Floor area and building mass should be reduced.

- G.** Architectural details on the upper stories should be at a scale that relates to the overall building composition.
- H.** Massing and details should be simple and proportionate to the scale of the building.
- I.** The length and depth of cantilevers should be minimized.
- J.** Where appropriate, building tops should be articulated.
- K.** Use elements such as: tapered or sculpted roof forms to create silhouettes against the sky (including false chimneys, towers, and decorative vents and caps); roof materials and overhangs to create strong shadow patterns and decorative cornices to provide visual interest.
- L.** Break up the horizontal lines of long parapets using variations in height or other appropriate design techniques.
- M.** Encourage a cohesive human development scale in the Planning Area.
- N.** Relate building heights and construction costs to the economic market.
- O.** Institute restrictions to the unlimited heights along National City Boulevard and Roosevelt Avenue.
- P.** Establish the greatest heights between National City Boulevard and Roosevelt Avenue around the Education Center in order to define the high intensity zone of the downtown core that falls off as it approaches the existing single-family neighborhoods.
- Q.** Create and maintain comfortable pedestrian areas, outdoor plazas, and lunchtime eating places, and create comfortable and pleasing residential neighborhoods.
- R.** Maintain adequate sunlight and air for sidewalks and residential areas during the winter solstice in sun access envelopes.
- S.** Encourage human scale in new buildings.
- T.** Design buildings as a carefully orchestrated compositions of smaller parts.
- U.** Reduce the perceived size, bulk, scale, and height of a building by either visually or physically dividing its mass into smaller scale components.
- V.** Reduce the actual bulk of a large building by dividing it into several smaller buildings to create a "campus" or "village".
- W.** Groups of smaller buildings are generally visually preferable to one large, bulky building, and are also more easily adaptable to a variety of uses.

7.4 DOWNTOWN DESIGN DISTRICTS

Many of the guidelines in this chapter will apply to all development zones in downtown, regardless of the location. To not repeat guidelines, the full range of built environment factors to be considered are included in downtown-wide guidelines at the end of this chapter. However, variances on the guideline are needed to be considered where land uses, context and district specific requirements may be more appropriate. Each of the following downtown design districts will have specific guidelines that only apply to that district as defined by current character, current scale and intended emphasis for that district.

DOWNTOWN DESIGN DISTRICTS



"Main Street Type" Retail District



Visitor/Education Village District



General Commercial District



Neighborhood Transition District

Figure 7-1: Downtown Design Districts

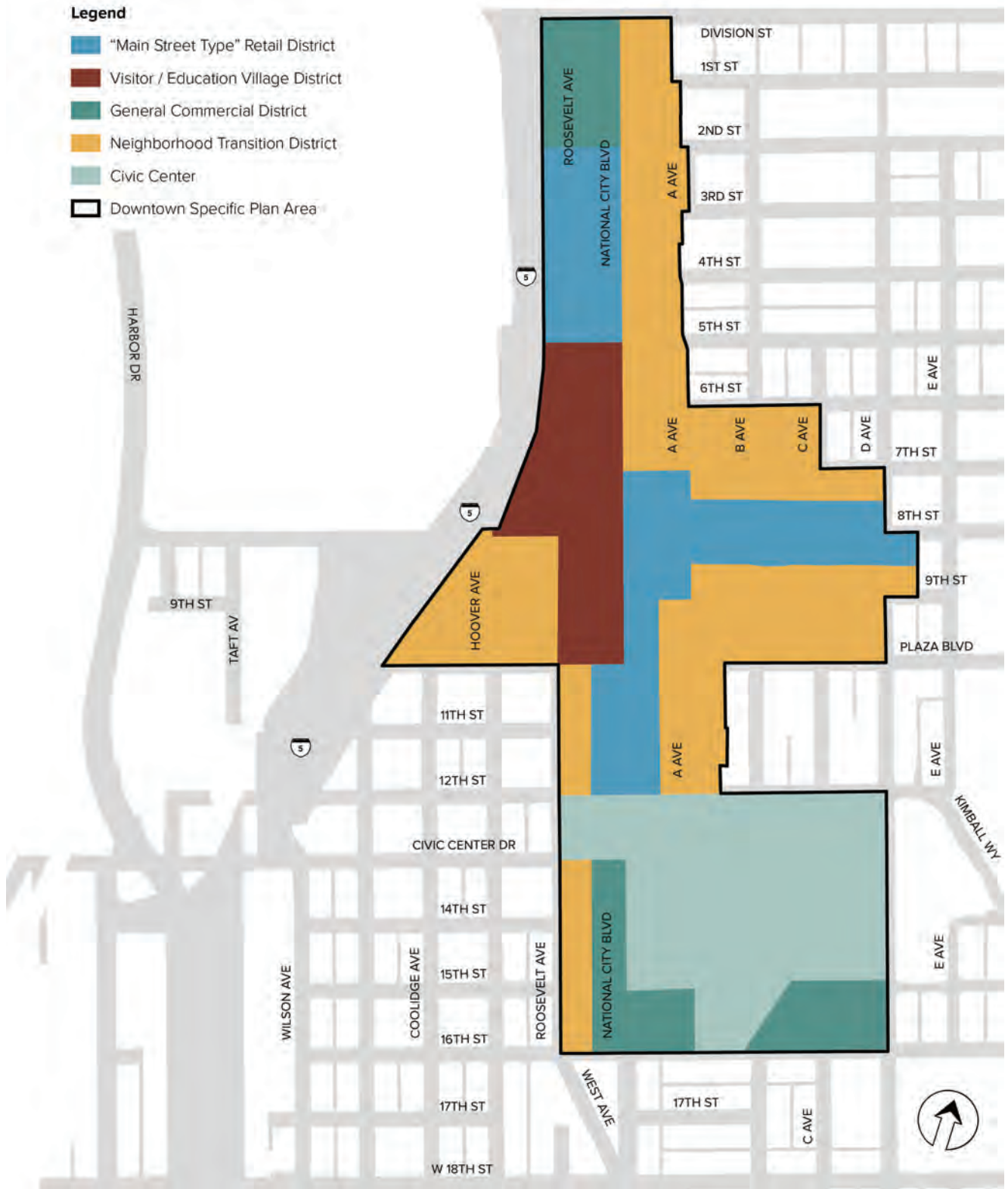

7.4.1 "MAIN STREET TYPE" RETAIL DISTRICT

7.4.1.1 Location and Setting

The "Main Street Type" Retail District extends along 8th Street, between National City Boulevard and D Avenue. These streets are reminiscent of typical main streets founds throughout the country. It also comprises sections of National City Boulevard, including properties to the west of National City Boulevard, between 2nd Street and 5th Street, and properties to the east side, between 7th Street and Plaza Boulevard. Additionally, this district includes both sides of the street, between Plaza Boulevard and 12th Street. This district consists mostly of older single-story commercial buildings that include retail, office, religious and restaurant uses.

7.4.1.2 Defining Character

The "Main Street Type" Retail District concentrates much of the activity and creates an identity for an entire area. It serves as a nexus of neighborhood life, providing a focus for specialty commercial activity and community events. This district has retail located at ground level on both sides of streets to create a lively pedestrian environment, with other higher density uses above. Building heights in the "Main Street Type" Retail District may be some of the tallest in the Planning Area, while keeping a consistent a "main street" architectural style and façade design.

Figure 7-2: "Main Street Type" Retail District Map

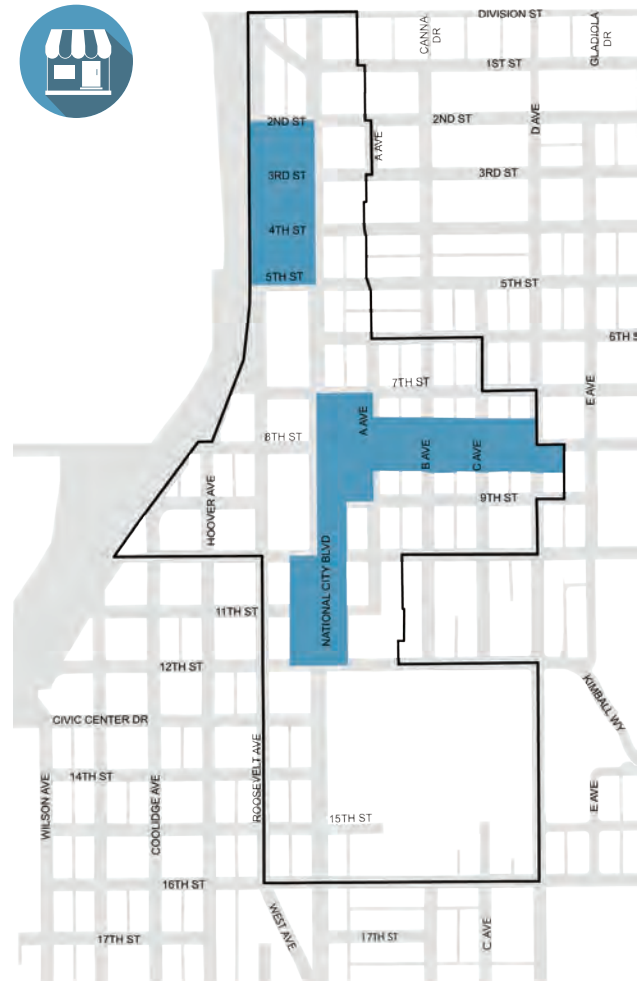

8th Street

Figure 7-3: Sample Block for "Main Street Type" Retail District

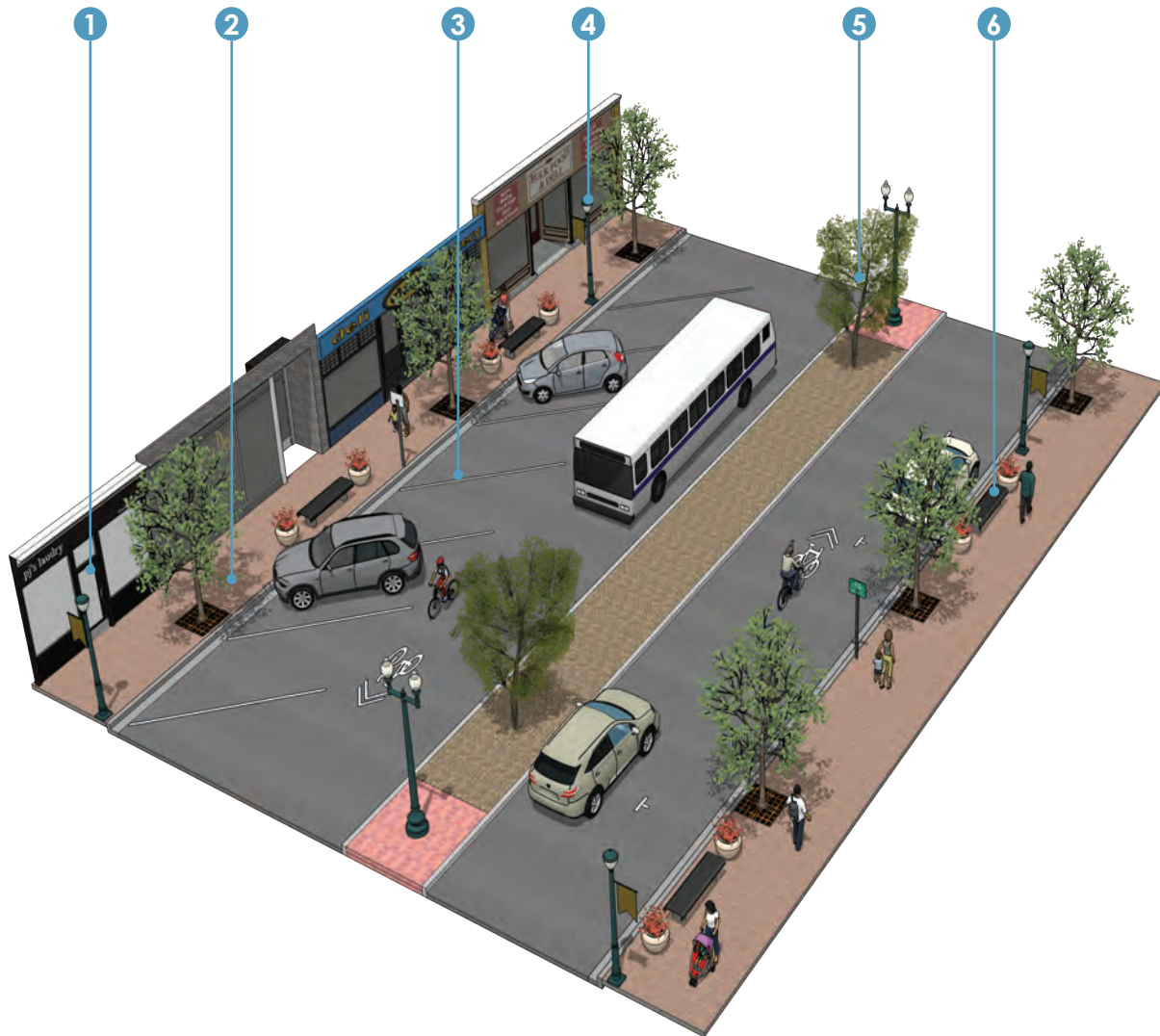

- 1 Main Street Architectural Style
- 2 Wide Sidewalks
- 3 Angled Parking
- 4 Street Lighting
- 5 Street Trees in Tree Grates
- 6 Urban Furnishings and Seating Area

7.4.2 VISITOR/EDUCATION VILLAGE DISTRICT

7.4.2.1 Location and Setting

The Visitor/Education Village District extends along the west side of National City Boulevard, between 5th Street and Plaza Boulevard. This district includes a variety of uses, such as commercial and retail uses, restaurants, and the Southwestern Community College Higher Education Center. The Visitor/Education Village District also contains various hotels, including the Ramada San Diego National City Hotel, the tallest building in Downtown National City.

7.4.2.2 Defining Character

The Visitor/Education Village District contains some of Downtown National City’s major activity areas, as well as high levels of pedestrians and vehicular traffic. This district incorporates a mixture of uses that includes commercial, retail, schools and hotels. The greatest densities and building heights in the Planning Area are permitted in this district. The Visitor/Education Village District should promote a lively mix of pedestrian-oriented uses in order to activate the area, while preserving its human-scaled environment.

Figure 7-4: Visitor/Education Village District Map

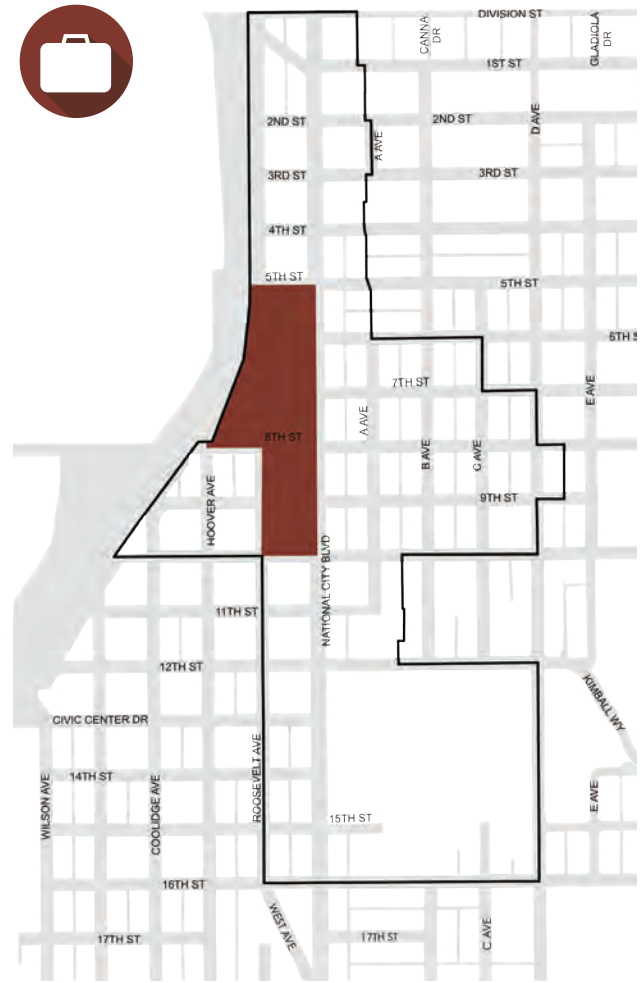

National City Boulevard

Figure 7-5: Sample Block for Visitor/Education Village District



- 1** Mix of Uses
- 2** Wide Sidewalks
- 3** Landscaped Median
- 4** Street Lighting
- 5** Urban Furnishings and Seating Area
- 6** Street Trees in Tree Grates

7.4.3 GENERAL COMMERCIAL DISTRICT

7.4.3.1 Location and Setting

The General Commercial District includes some properties to the west of National City Boulevard. The first section is located at the northern edge of the study area, between Division Street and 2nd Street. The second one lies at the southern edge of the Planning Area, between Civic Center Drive and 16th Street. Additionally, this district extends along the north side of 16th Street, between Roosevelt Avenue and D Avenue. This district is characterized by one or two-story buildings and a variety of uses that include hotels, retail and auto shops.

7.4.3.2 Defining Character

While the Main Street and Visitor/Education Village Districts focus on pedestrian traffic, the General Commercial District is oriented towards automobile traffic. Sections of National City Boulevard and 16th Street have older one and two-story commercial buildings with street-facing parking lots. Future development in the General Commercial District should focus on safe and efficient parking and circulation by locating parking to the rear of development when possible.

Figure 7-6: General Commercial Emphasis Map

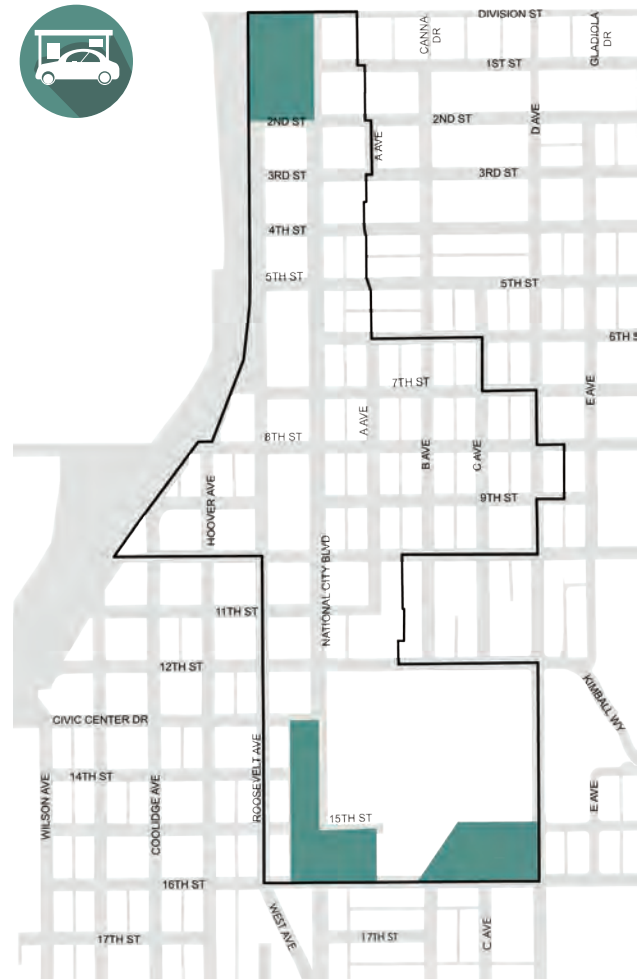

National City Boulevard at Roosevelt Avenue

Figure 7-7: Sample Block for General Commercial District

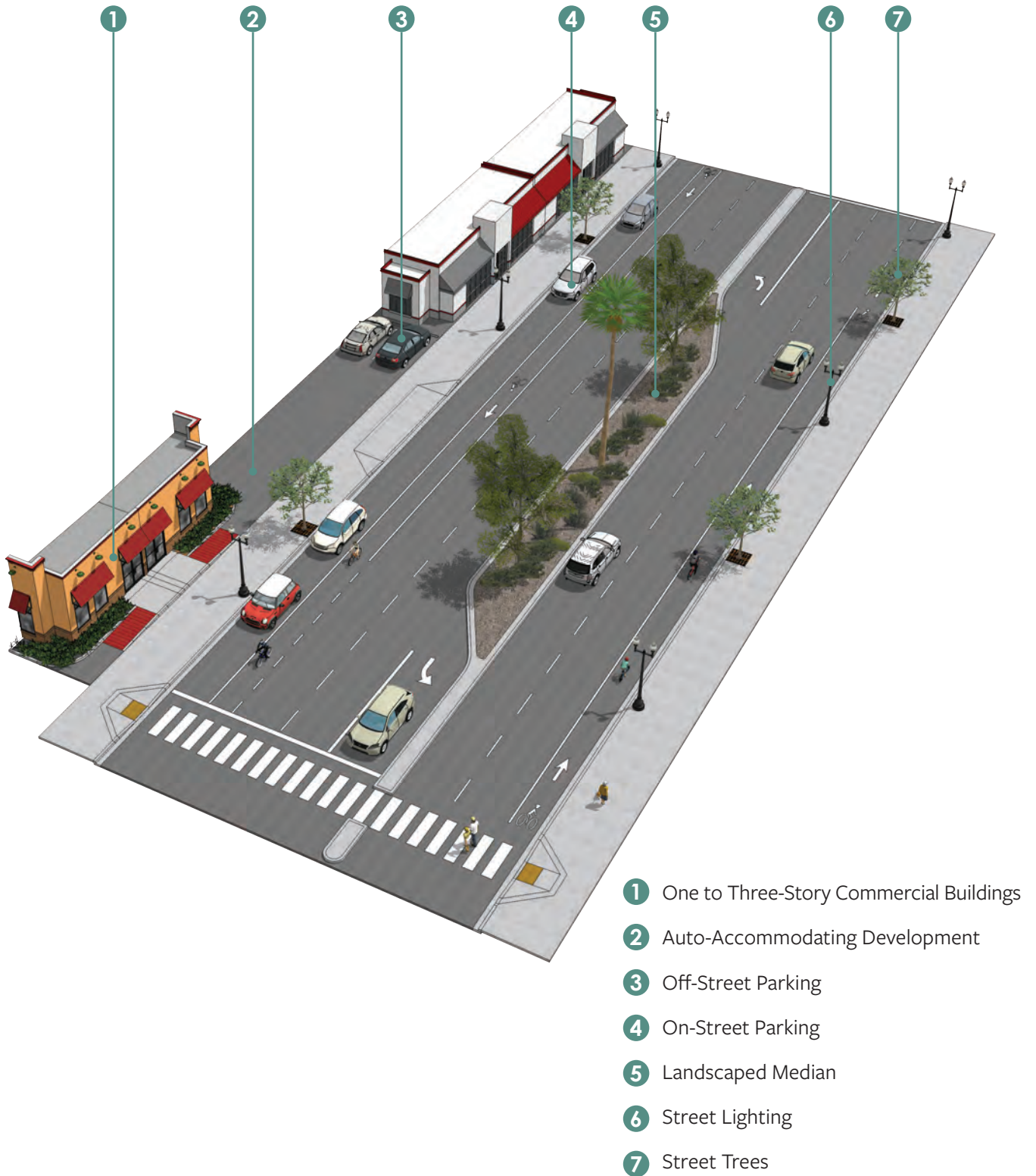

- 1 One to Three-Story Commercial Buildings
- 2 Auto-Accommodating Development
- 3 Off-Street Parking
- 4 On-Street Parking
- 5 Landscaped Median
- 6 Street Lighting
- 7 Street Trees

7.4.4 NEIGHBORHOOD TRANSITION DISTRICT

7.4.4.1 Location and Setting

The Neighborhood Transition District encompasses the areas adjacent to the Main Street, Visitor/Education Village and General Commercial Districts. This district acts as a transition area between the busier commercial and retail-focused districts and the quieter residential uses located immediately outside the Planning Area. These areas consist mostly of older residential buildings, as well as some offices, warehouses, auto shops and other light industrial uses.

7.4.4.2 Defining Character

The proposed urban scale of the Neighborhood Transition District is designed to be complimentary to the area and steps down from the busier, denser commercial districts to the adjacent residential uses. This district will support some uses that provide goods and services to the surrounding neighborhoods. Pedestrian improvements and small urban plazas can be used to activate this district, while promoting a comfortable connection between Downtown and the neighboring residential areas.

Figure 7-8: Neighborhood Transition Emphasis Map

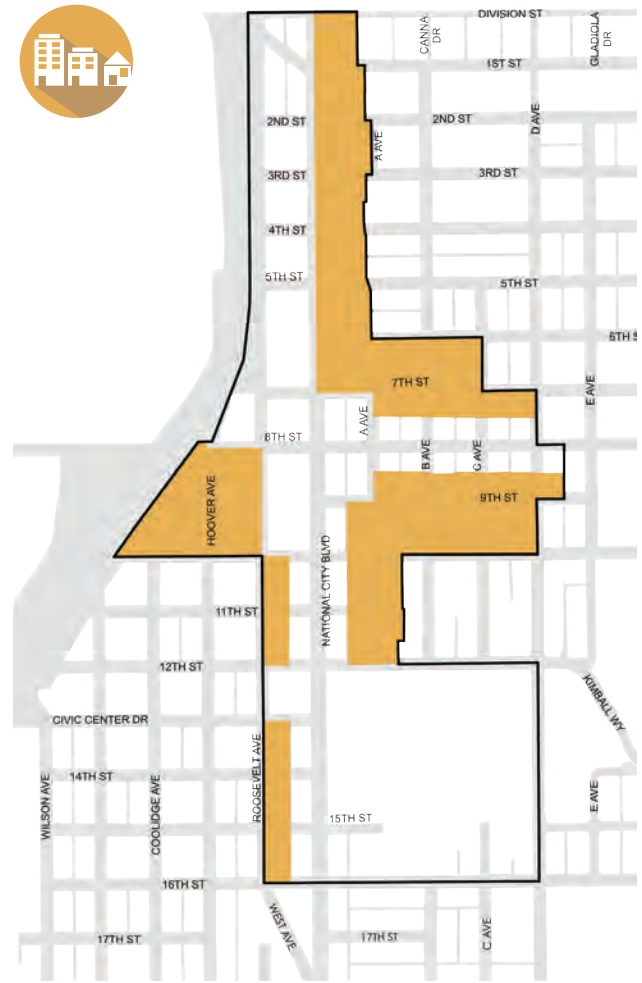

National City Boulevard at Osborn Street

Figure 7-9: Sample Block for Neighborhood Transition District



- 1 Mix of Uses with Emphasis on Residential
- 2 Parkway
- 3 On-Street Parking
- 4 Medium to Low Density Transitions
- 5 Street Trees
- 6 Street Lighting

7.5 BUILDING DESIGN GUIDANCE

The goal of this Specific Plan is to facilitate the development of a vibrant and lively downtown environment that promotes livability, walkability and a sense of community within the urban heart of National City.

The Specific Plan is intended to allow for the growth of an additional 5,500 dwelling units (minus 200 built since the previous plan was adopted) within the downtown core over the next 10 years. Developing a varied and dynamic housing stock that reflects the diversity of National City in addition to a mix of supporting and complementary uses (institutional, office and retail) and open spaces that will promote a quality, safe, and stimulating urban environment for people to live, work and play in downtown National City.

The plan is also intended to incentivize transit-oriented development with a pedestrian friendly series of streets and connections. The process of developing a vibrant, built environment must be focused on place-making for social interactions, community building and street life. The synergies created from a variety of streetscape activities with the volume of residents, workers, and visitors to activate them can elevate the downtown experience and reduce the reliance on vehicles.

7.5.1 DEFINING THE URBAN VILLAGE

The primary intent of the plan is to establish an urban village as a mixed-use, walkable, and urban downtown. The urban village is to be a destination within National City where the community, students, downtown workers, and residents may come to live, work, or play within an enjoyable walkable area. The 8th Street revitalization project has culminated in a pedestrian friendly centerpiece in downtown that links the civic & private realms to create a positive neighborhood environment.



Public space



Commercial development



Urban square

Open space and its various types of public spaces, plays a significant role in how people experience the urban environment, providing an interface between the public and private realms that unites them into a seamless whole. Landscape provides a natural element to the urban form, softens and frames views, and can also screen unattractive elements. Historically, National City developed with relatively generous spaces for gardens and landscaping in a large urban context. As the scale of development in the National City community increases, these spaces need to be refashioned for a more urban context rather than become vestiges or eliminated altogether. Maintaining setbacks to include room for landscape designs that are attentive to detail with thoughtful placement and layering of plant material is therefore important. This includes plantings along building street frontages and required yard areas as well as in interior courtyards, plazas, and paseos.

A primary task of architecture, landscape, and urban design is the physical definition of both public and private spaces and streets as places of shared use and commerce. How buildings front onto the sidewalk define street walls and the articulation of the buildings define community character. The “Main Street” style of Downtown National City is defined by shallow setbacks with varying shop fronts, stoops, and forecourt types of building frontages. This is the character of parts of the downtown that need to be expanded in order to create an urban village center for National City. Alterations and additions to the downtown National City urban fabric should build upon the scale and character of the village, promoting activation and interest at the streetscape level.

Building frontages define the streetscape environment. The design of the building frontage is an expression of the context of street design from downtown’s most urban core to its less urban edges transitioning to its surrounding neighborhoods. The frontage of public and private build-

ings impact site design and ultimately affect the scale, character, and pedestrian friendliness of the public realm. The intent is to encourage high quality design of building frontages and public spaces that will create an inviting and visually interesting downtown.

While landscape plays a significant role in residential and residentially-oriented mixed-use areas, it is also important in commercial areas where creating comfortable and attractive places for people is critical to successful retail. Landscape and open space plays an important role in a number of residential and commercial building typologies that are typical to the areas temperate climate, including courtyard housing where units are oriented around a central open space and retail development organized around plazas and paseos.

In urban villages, we see and experience buildings with activated street frontages on the ground floor and a mix of either institutional, business, hotel and/or housing on upper floors. Urban Villages are built upon the interrelationships of its streets, parks, and buildings. A walkable mixed use village means it is possible to walk from your home to your office, which might be just a few minutes down the street. Along the way you would pass stores from which you can easily make purchases, without traveling across multiple suburbs.

The urban village is a planning concept with the goal to create the following environment:

- Where people can live, work, learn, and play.
- Which has demographic diversity.
- Which has varied housing typologies.
- Which is self-sustainable and environmentally friendly.
- Which encourages community development and bonding.

7.6 PRIVATE REALM DESIGN GUIDANCE

7.6.1 DEFINITION OF PUBLIC REALM AND PRIVATE REALM

The public realm can mean a walkway that falls in the street right of way. A successful public realm is where there is a transition from the public space to private space, often without the individual realizing they are on private property. It can mean small outside eating areas, push-outs into the right of way or recessed areas that are inviting to the users of the street. The transition from fully public owned and used spaces to private spaces inside buildings is critical in creating an activated street environment.

The private element in the term private realm are all spaces where an individual is not invited into spaces, are privately owned and must be designed to offer privacy. This part of the private realm is not controlled or dictated by these guidelines. However, the part of the private realm that these guidelines are concerned about, is the transition zone. All well designed areas have a clearly defined public space, space that is considered semi-public where anyone would feel welcome to use, to semi-private space where a person knows they are being invited into privately owned areas and then the private space that should be clearly defined through physical design features. These guidelines are divided between the private realm, or development edge of projects, where an applicant is responsible for creating and financing these spaces, and the public realm that is either financed partly by the adjacent development or through public sources of funding. There may be areas of overlap between these two parts of a downtown area, but a successful street environment requires the blurred edge between public and private, so elements of these guidelines may also appear to be blurred, but this approach helps to create the type of environment needed for an activated downtown. This zone is referred to in this document as the “fine line”.

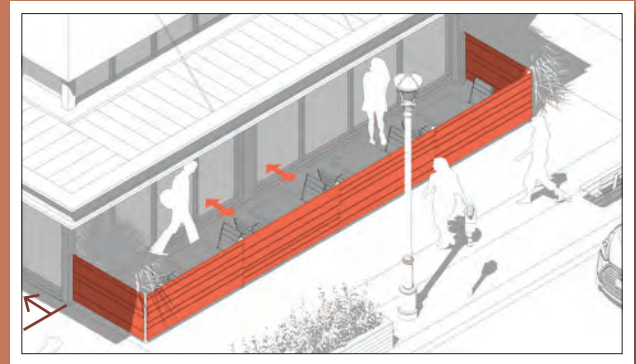

Private space

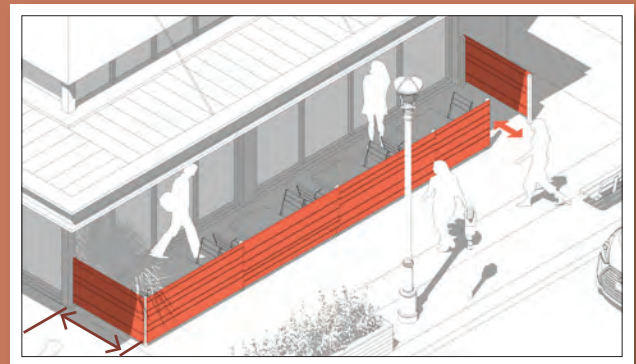

Semiprivate area

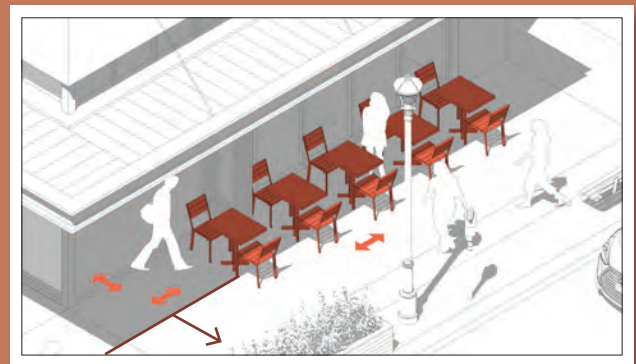

Public space

7.6.2 THE “FINE LINE”

The use of outdoor space by the public, whether privately developed or publically financed, is one of the most important elements in creating a downtown village that draws residents and visitors and activates the street environment. As explained in the previous section, the interface between the street and buildings, is an important focus of these guidelines. The following are general guidelines on how to create this “fine line” between public open space and private development. Most guidelines apply downtown wide, however, guidelines that are specific to certain design districts display the relevant design district icon.

7.6.2.1 General Guidelines

In general, encourage onsite private open space and landscaped areas as an element of the building and site design on all, by using entryways, outside retail, seating areas, pocket parks and courtyards. The following should be considered for all projects:

- A.** Provide on-site outdoor open space as an amenity that is designed as a central-organizing principle of the development rather than as an afterthought.
- B.** Features such as pools and sport courts (and indoor gyms) are encouraged for larger developments to provide a recreation component and provide an indoor visible public use of private spaces.
- C.** Use landscaping to activate building facades, soften building contours, highlight important architectural features, screen less attractive elements, provide shade, and add color, texture, and visual interest. Select high quality landscape materials suitable for the San Diego coastal climate.
- D.** Integrate semi-public outdoor spaces such as on-site plazas, patios, courtyards, paseos, terraces and gardens to address the public realm and support pedestrian activity and community interaction.
- E.** Delineate plazas and courtyards through building and landscape design.
- F.** Ensure that plazas and courtyards are comfortably scaled, landscaped for shade and ornament, furnished with areas for sitting, and lighted for evening use.
- G.** Courtyards accessible from the primary street should be surrounded by active facades or landscape treatments.
- H.** Semi-private patios may be in courtyards if they are defined by a low wall or hedge.
- I.** Provide a variety of seating options, such as benches, seat walls, and broad steps.

7.6.2.2 Building Edges

Maintain building alignments parallel to the street with a consistent setback from the front property line to clearly defines the edges of streets, parks, and open spaces to promote a vibrant pedestrian environment. Accomplish this by:

- A.** Building frontages should be oriented towards the street with well-defined entrances to clearly establish which are public entrances versus private entrances.
- B.** Avoid blank side walls visible to a street.
- C.** High-quality materials or material applications should be proposed to create visual interest.
- D.** To establish continuity between sub-districts, all new developments in the Planning Area, regardless of size or use, should reflect a similar urban form that is human-scale and pedestrian-oriented, with strong physical and visual connections to fronting streets.
- E.** Maintain a high degree of visual and physical access to support retail and promote a vibrant and safe public realm.
- F.** Minimum ground-floor ceiling height for buildings, measured from the average grade of the adjoining public sidewalk, should be the aver-

age of 12 feet for buildings containing ground-floor residential uses and 15 feet for buildings containing ground-floor non-residential uses.

- G.** Commercial space depth on ground-floor spaces should be 25 feet along 75 percent of the commercial space frontage along a public street or 40 feet along 75 percent of the commercial space frontage along main streets. Along general commercial streets should have 15 feet along the remaining 25 percent of the commercial frontage to accommodate other internal functions of the building. 
- H.** Orient buildings towards public (and private) streets to positively define street edges.
- I.** Place the main building entrance on the primary street frontage.
- J.** Orient primary building entrances onto street frontages rather than parking lots.
- K.** Incorporate features such as windows, doors, and other architectural elements that activate the facades and provide visual interest for building facades that face streets or are adjacent to sidewalks or pedestrian pathways (e.g., paseos).
- L.** Maintain quality architectural articulation and finishes around all visible sides of the buildings, not just the building fronts.
- M.** Ensure primary building entrances front onto public streets, are well-defined, clearly visible, and universally accessible from the adjacent public sidewalk.
- N.** Differentiate between residential and commercial entrances in mixed-use buildings.
- O.** Provide an entrance to each ground floor residential unit, which is identifiable and directly accessible from the public sidewalk.
- P.** Where building entrances are set back by a plaza or forecourt, maintain high visibility and direct, universal access from the public sidewalk.
- Q.** If a base building provides access to more

than one tower or more than one use within a tower building, ensure that the entrance to each is clearly identifiable, visible, and universally accessible from the public sidewalk.

- R.** Coordinate the location of building entrances with transit stops and passenger loading zones.

7.6.3 PRIVATE REALM DEVELOPMENT GUIDELINES

Encourage creative design solutions that acknowledge contextual design through emulation, interpretation, and/or contrast in character of neighboring buildings and spaces.

7.6.3.1 General Guidelines

For private realm development, the City should consider the following:

- A.** Complement the architectural character of existing historic buildings and promote harmony in the visual relationships and transitions between new and older buildings.
- B.** Encourage building design that is responsive to the built form and character of surrounding development.
- C.** Relate the bulk of new buildings to the prevailing scale of existing development to avoid an overwhelming or dominating appearance in new construction.
- D.** Promote functional and aesthetic integration of building services, vehicular access, and parking facilities.
- E.** Promote sustainability in building design, construction, and operation.
- F.** Design infill to complement the architectural styles of the block. If there is a mixture of styles on a block, then the design of the new development should be responsive to the shared characteristics of the existing developments (e.g., setbacks, heights, massing, etc.).

- G.** Explore new stylistic interpretations of traditional architectural vocabulary in new development.
- H.** Incorporate architectural features and detailing proportional to the scale of the surrounding block development.
- I.** Ensure that all elements (i.e. additions) in a structure are consistent with that structure's overall design.
- J.** Use stylistically cohesive, character-defining features, such as porches, columns, balustrades, brackets, rafters, and decorative trim, to enhance visual compatibility.

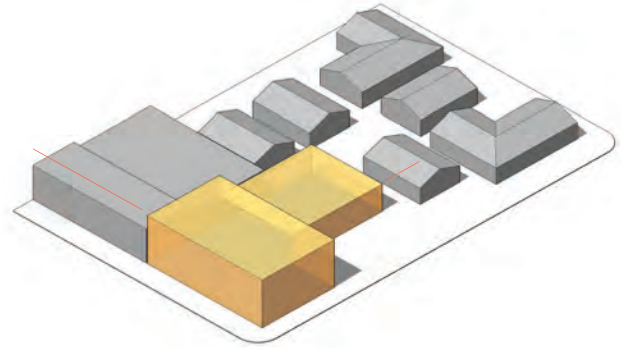

Private realm development should complement the existing architectural character of the area

7.6.3.2 Build-to Lines

Establish a consistent alignment of building frontages. The distance buildings are setback from the street helps to define the character of the public realm. Building setbacks and build-to lines are the tools used to establish a consistent street wall. Guidelines that create consistency along streets should include:

- A.** Ensure that new development responds to the prevailing setbacks of surrounding development.
- B.** Design buildings in commercial and mixed-use areas to either an agreed upon minimum setback line or to the prevailing setback along the street in order to create a consistent and well-defined street frontage. 🏢 📄 🚗
- C.** Do not locate surface parking areas between the building frontage and the public street right-of-way in any circumstances. 🏢 📄
- D.** Establish minimum setbacks that contribute to a wider pedestrian zone in the community's commercial areas to support an active and well-furnished pedestrian environment.
- E.** Include public or semi-public spaces such as plazas, courtyards, forecourts, and sidewalk cafes, adjacent to the public right-of-way.

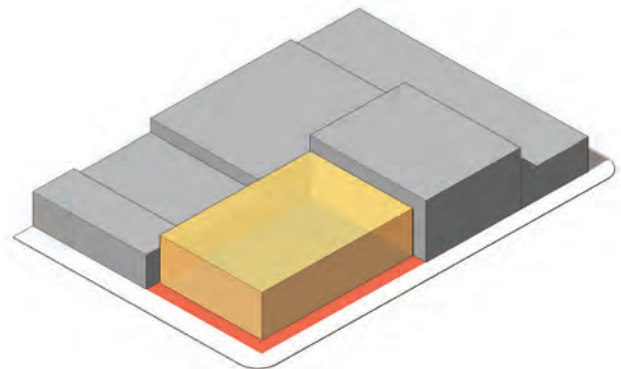

Establish minimum setbacks

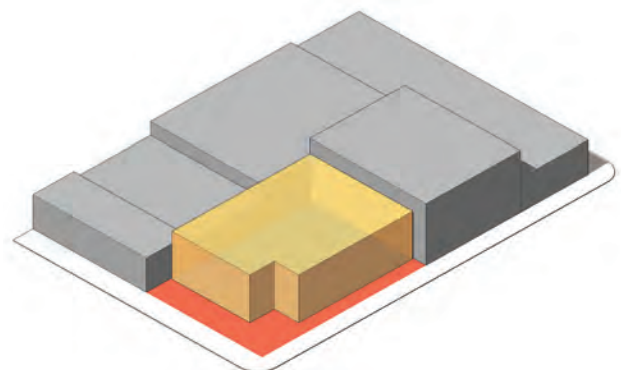

Include public or semi-public spaces in building design

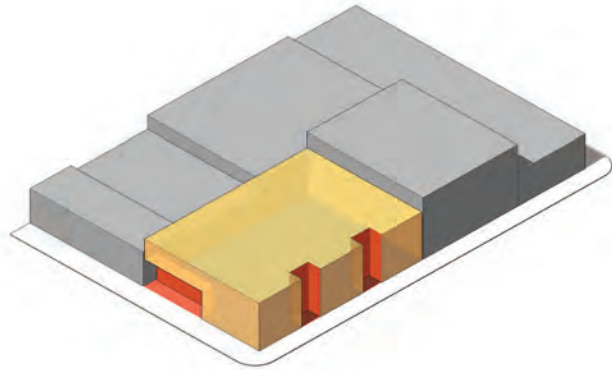

Create interesting façades

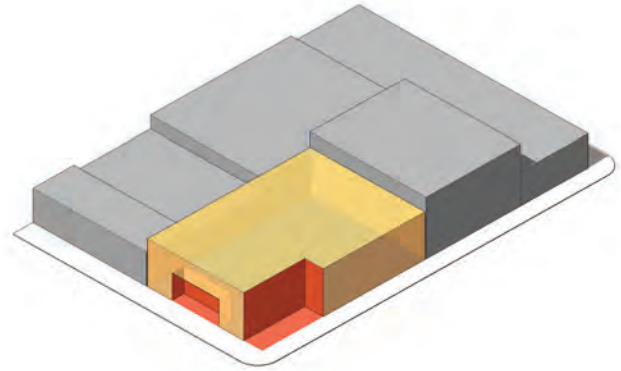

Use building setbacks for ground-floor retail

- F.** Design buildings such that at least 80 percent of the building frontage is setup to the minimum setback line. 🏢 📏
- G.** Allow minor variations in the building frontage to create more interesting façades, which will be credited toward the minimum setback percentage requirement. Minor variations include recessed building entries, vertical recesses up to three feet deep and four feet wide, and building setbacks up to 2 feet from the minimum setback line.
- H.** Utilize building setbacks for ground-floor retail uses for spillover activity such as outdoor café seating and adequate space for pedestrian movement. A portion of the front setback may be increased by as much as 15 feet if that setback is used as public space (i.e. outdoor restaurant seating or a courtyard with public access). A minimum of 60 percent of the front facade should be constructed up to the front setback. 🏢 📏

7.6.3.3 Outside seating areas encroaching in Right-of-Way

Secure a sidewalk encroachment zone a minimum of 5 feet wide or greater for outdoor dining along the primary street frontage. Make sure to:

- A.** Incorporate public seating, café and restaurant spaces, patios, and plazas along the sidewalk to activate the public realm along the street in either the encroachment or furnishing sidewalk zones. 🏢 📏 🚶
- B.** Include the building setback to resolve competing demands for space for outdoor seating, pedestrians, street furniture, street trees, and utilities with a wider overall sidewalk zone. Always assure that a minimum of 5' is left free of all obstructions for pedestrian and ADA access. 🏢 📏 🚶

7.6.3.4 Architectural Projections into Public Right-of-Way

Projections refer to architectural elements, such as cornices, balconies, window bays, and sun shades that may extend into the setback zone. These will only be allowed if the following guidelines are adhered to:

- A.** Ensure projections are placed at a height or distance from the street frontage that do not impact pedestrian movement or conflict with street trees or lighting needed along the street.
- B.** Design projections carefully to ensure that their scale and location is appropriate.

- C.** Encourage architectural elements that add visual interest and enhance the user experience.
- D.** Include canopies and awnings on buildings to protect pedestrians from summer heat and winter rain and to contribute variety to storefronts and building entries.

Canopies and awnings should:

- E.** Provide 8-foot minimum clearance above the finished sidewalk grade.
- F.** Leave at least 25 percent of the sidewalk unencumbered to accommodate street furnishings, lighting and street trees.
- G.** Be consistent with the building's architectural style and avoid obscuring distinctive architectural features.
- H.** Be either permanent architectural features that incorporate materials consistent with the building's architecture or colored fabric mounted over a metal structural frame.
- I.** Avoid using shiny, flimsy or internally illuminated fabric.

Window bays add visual variety and interest to building facades and enhance the connection between public and private realms. Window bays should:

- J.** Be either squared-off or have angled returns.
- K.** Encroach no more than 3 feet into the public right-of-way.
- L.** Have a maximum horizontal width of 8 feet (the angled return is in addition to the 8 feet in width).
- M.** Have at least 6 feet horizontal separation between window bays.
- N.** Allow at least 12 feet clear from top of sidewalk to underside of projection.

Balconies add visual variety and interest to build-

ing facades and create an active connection between public and private realms. Their use should utilize the following guidelines:

- O.** Encroach no more than 3 feet into the public right-of-way.
- P.** Have at least 10 feet horizontal separation between non-contiguous balconies.
- Q.** Allow at least 12 feet vertical clearance from the sidewalk.

Cornices which are continuous horizontal courses or moldings along the top of building facades, help to define and add character to buildings. Their use should be guided by the following:

- R.** Be used to create a consistent relationship between new and old buildings by establishing a consistent streetwall height along the length of the street.
- S.** Be used to reflect changes in building form.
- T.** Be of substantial depth to create a shadow line that clearly defines the top of the facade.
- U.** Not project more than 3 feet into the public right-of-way.



Horizontal cornice

Sunshades as architectural features can be used to control solar exposure into building interiors to limit heat gain, prevent glare, and enhance daylighting by re-directing and deflecting sunlight. Only use these with this guidance:

- V.** Be constructed of high-quality and durable materials.
- W.** Be designed as an integral element of the overall building design that adds architectural distinction.

7.6.3.5 Building Orientation

Encourage primary, ground floor building entrances to be oriented towards plazas, parks, or pedestrian-oriented streets, not to interior blocks or parking lots. New buildings should:

- A.** Be built to the minimum setback requirements to create a safer and more active street by allowing residents to more easily watch over the street.
- B.** Be built to provide an appropriate setback to allow rear- and side-yard facing windows on existing buildings to have access to light, air, and usable space between buildings.
- C.** Should have entries in mixed-use buildings that are separate and distinct from commercial entrances.

7.6.3.6 Street Corners and Building Interface

Encourage corner sites to respond to the setback pattern and alignment of neighboring buildings on both streets. Buildings located on corners are especially positioned to activate the public realm and add visual interest to the pedestrian environment. Corner buildings draw activity from four directions and are ideally situated for active ground-floor uses and commercial spaces with greater and more functional depths. They also offer the opportunity to define street character with bold architecture, vertical height elements, and/or place-making features. Designs for buildings situated on corners may include design enhancements on the ground floor, such as enhanced building entrances and ornamentation, as well as

design treatments for upper story volumes, such as variations in material and color, lighting treatments, and/or distinctive canopies. Consider:

- A.** Designing corner buildings to engage and add interest to the public realm.
- B.** Encouraging urban/micro plazas for community activation and gathering at corners.
- C.** Locating entrances at the corner to anchor the intersection and create a seamless transition that captures pedestrian activity from both street frontages.
- D.** Accentuating the corner's unique location with architectural features that actively engage the public realm and create a visual presence at the corner, such as chamfered or rounded corners, projecting and recessed balconies and entrances, features such as embellished doorways and volumetric manipulations (e.g. towers), enhanced window designs that may include floor-to-ceiling windows, display windows, clerestory windows, or distinctive glass design or colors.
- E.** Incorporating architectural design features that highlight the gateway and create a sense of entry at gateway locations.

7.6.3.7 Building Articulation

Ensure a building's articulation breaks up the volume and shape of buildings. The articulation reveals how the surface or form of a building is defined through shade devices, balconies, windows, and all the meaningful parts that define the building's character. Articulation should consider the following:

- A.** Buildings should incorporate arcades, trellises, horizontal shading devices, and appropriate tree planting along the base of the buildings.
- B.** Vertical shade elements should be emphasized on the southern and western sun exposure.
- C.** Change in building articulation through color, attachment, vertical dividers, or the use of perimeter landscaping (e.g., foundation plantings

or wall vines) should occur at least every ten feet of horizontal space.

- D.** Unavoidable blank walls along public streets or those viewed from public streets, open spaces, and thoroughfares should use graffiti-resistant surface materials and be enhanced with architectural detail in material texture, scoring, banding, ornamentation, landscape treatment, and/or artwork.
- E.** Ground floor frontages adjacent to public streets or open spaces should be articulated with entrances, lobbies, storefront windows, and displays to avoid blank ground-floor facades.
- F.** Arcades, porches, bays, and balconies are encouraged. In no case should the ground floor façade of a building consist of an unarticulated blank wall or an unbroken series of garage doors.
- G.** The ground floor of residential building facades should be articulated at regular increments to differentiate individual residential units from each other and from the overall massing of the building and to express a rhythm of individual units along the street.

Orient active portions of buildings and facades with windows to allow for surveillance of exterior areas, particularly plazas and other public spaces where people may gather. Window guidelines include:

- H.** Windows should be positioned to enhance public views and views of streets and public places to allow people to more easily watch over the street.
- I.** Windows should be maximized to provide visibility of adjacent public spaces. Building facades that face public areas should have a minimum of 50 percent transparency. The view out of windows should not be blocked by shelving and displays.
- J.** Window placement should relate to adjacent sites to allow maximum sun and ventilation and enhance privacy between buildings.
- K.** Operable windows should be used wherever possible to allow passive ventilation, heating, and cooling.



Corner interest in public realm



Trellis and shade devices at ground level



Ground floor step-up residential

Primary building entrances on all buildings should face the primary abutting public street or walkway, or be linked to that street by a clearly defined and visible walkway or courtyards. Building entrances should:

- L.** Be accentuated with architectural elements, lighting, and/or landscaping.
- M.** Provide on-site connectivity to provide the pedestrian safe passage from the sidewalk to a continuous path which connects the primary entrances of the structure(s).
- N.** Provide clear and continuous paths from every primary building entrance to all sidewalks, crosswalks, transit stops, and parking lots directly adjoining the site.
- O.** Have awnings, overhangs, and arcades along commercial facades to provide overhead protection for pedestrians and to create significant entrances.
- P.** Additional secondary entrances should be oriented to a secondary street or parking area.
- Q.** Recessed entrances should not exceed 15 feet in width and the face of the door or gates should be within 15 feet of the property line.
- R.** Porches, steps, entryway roofs, roof overhangs, hooded front doors, or similar architectural elements should be used to define the primary entrances to all buildings.

Ensure that the massing of new projects or major additions, are complementary to adjacent buildings and ensure that they do not negatively impact the character of a neighborhood. Buildings should:

- S.** Incorporate a variety of vertical and horizontal step backs to break up continuous horizontal or vertical volumes.
- T.** Encourage upper-story step backs to introduce an increased number of floors that are not common in the area.

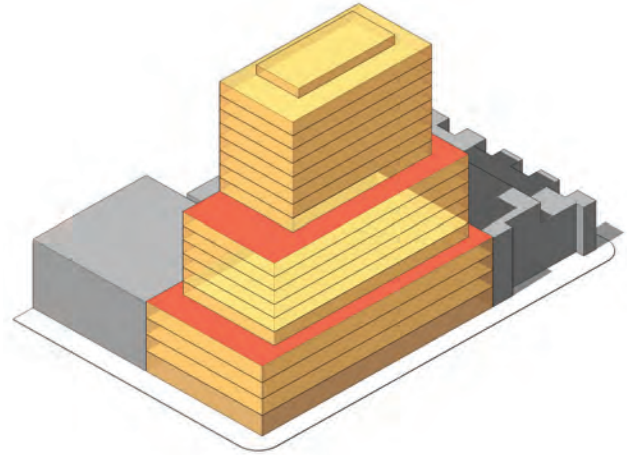

Upper-story step backs should be encouraged

- U.** Provide a vertical transition between high-density development and any adjacent lower density development. This can be accomplished by varying the massing within a project, stepping back upper stories, using balconies, and varying sizes of elements to transition to smaller-scale buildings.
- V.** Vary the rooflines of a building to diminish the massing.
- W.** Step down building heights along the secondary frontage and rear of buildings to reduce the impact on adjacent lower height properties.
- X.** Utilize step back areas to encourage active uses such as balconies or roof gardens. These areas provide additional open spaces for residents and add more “eyes on the street.”
- Y.** Design at a compatible scale and massing to development on either side of streets (facing each other) to maintain a sense of visual cohesion along the street.
- Z.** Design buildings to allow natural ventilation using courtyard designs, arcades, canopies, and other passive space-cooling techniques.

7.6.3.8 Height and Massing

Downtowns should contain an eclectic variety of buildings in its commercial and mixed-use areas, ranging in scale, style, use, and material, among other attributes. Building scale and massing must be considered for all development zones of downtown, especially those in the neighborhood transition zones. All zones should consider these guidelines. Neighborhood transitions will be required to follow these guidelines including:

- A.** Employ a combination of building setbacks, upper-story step backs, and articulated sub-volumes to sensitively transition to adjacent lower height.
- B.** Consider factors such as the quality and likely longevity of adjacent buildings as well as permitted zone heights when determining sensitive height transitions in areas identified for higher intensity development.
- C.** Stepback upper floors of buildings above the fifth story (or between 65 and 85 feet) in order to define downtown’s core areas while maintaining a comfortable pedestrian friendly scale along the street.
- D.** Design buildings with simple, yet varied, massing. Utilize features, such as street wall indents, deep entry and window openings, balconies, window bays, and a top treatment (i.e. a roof, cornice or parapet) to add variety and interest. Street wall indents are strongly encouraged when accommodating outdoor eating for retail establishments to minimize the extent of future sidewalk encroachments.
- E.** Design taller buildings to differentiate between the building’s base, middle, and top sections in order to reduce the apparent mass.

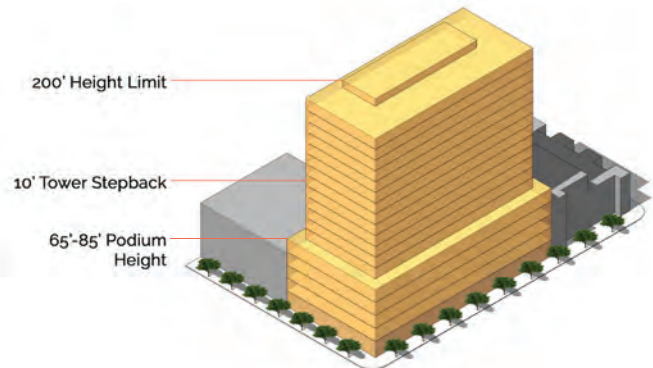

200' height, massing & setbacks in core zones

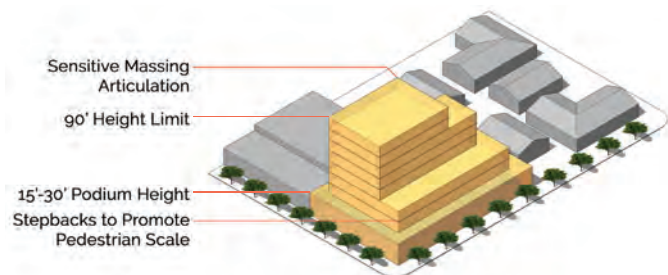

90' height, massing & setbacks in core zones

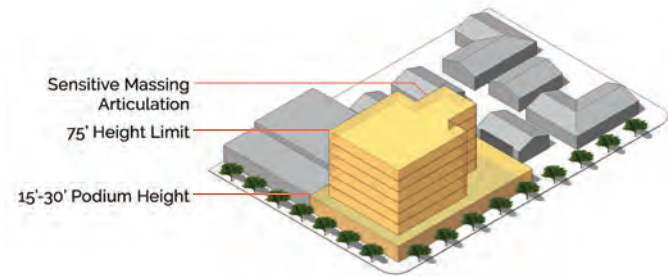



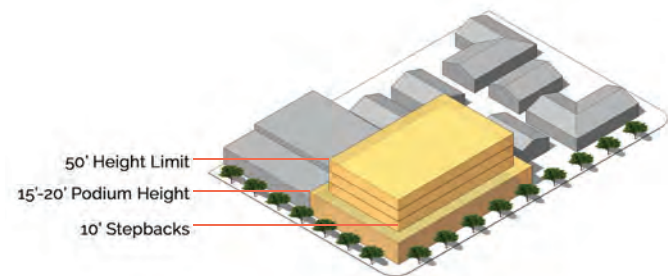



75' height, massing & setbacks in core zones



50' height, massing & setbacks in core zones



7.6.3.9 Height and Massing Transitions to Residential Neighborhoods

The scale, massing, and detailing of buildings has a substantial impact upon neighborhood character. Nearly all of the buildings in the city's residential areas are less than three stories (35 feet) in height, and the vast majority are one or two stories. In order to ensure complementary infill and new development, establishing consistent massing and configuration of new buildings is crucial to producing high-quality, memorable architecture that is compatible with established development patterns. To provide more compatible development, the following policies apply to new development and additions that transition to predominantly residential neighborhoods:

- A.** Promote residential building heights, massing, and setbacks that are responsive to the surrounding residential neighborhood scale and massing. 
- B.** Utilize transitional treatments to lower the contrast of scale for any project that is more than twice the number of floors. 
- C.** Design structures with massing and façade articulation that contributes to a fine-grained, pedestrian scale environment at street level.
- D.** Design new and modified buildings to conform to the predominant scale of the neighborhood and/or particular block and be sensitive to the scale of adjacent uses.
- E.** Employ a combination of building setbacks, upper-story stepbacks, and articulated sub-volumes to sensitively and adequately transition to adjacent lower height buildings. 
- F.** Set back upper-story additions from the primary façade to preserve the original scale and form of the building at the front setback.
- G.** Design the massing of buildings on combined lots to respond to the pattern and rhythm of both adjacent development and the prevailing development within the block. 
- H.** Design buildings with simple, harmonious proportions that reflect the neighborhood's historic buildings and residences (this does not mean match the height and size of these examples, but include this residential or main-street type of scale in the fenestration of elevations and building forms). 
- I.** Use features such as porches, stoops, deep entries, window openings, balconies, window bays, eaves, and rooflines to add variety and interest, and to mitigate apparent massing scale issues. 
- J.** Avoid excessive roof breaks and overly complicated roof forms. 
- K.** Address climatological considerations through building articulation to access the ideal amount of sunlight and air that will result in changes in the massing and form of the development.

7.6.3.10 Transitions

Assure new building heights will not detract from local neighborhood character. This is done most successfully through design guidelines that address setbacks and upper-story stepbacks for the portion of a building over a certain threshold. Applying these guidelines will ensure that new development will be sensitively designed to complement the character of the surrounding neighborhood and achieve a timeless quality design. Consider:

- A.** Adhere to transition area guidelines to ensure that infill development and additions are appropriately designed to address neighborhood context. 
- B.** Incorporate upper story sideyard step backs from adjacent buildings of 10 feet above the 5th story, or 65 feet to adjacent parcel. 
- C.** Limit the bulk of towers, or buildings over 85 feet, to single floor plates that should not exceed 20,000 square feet.

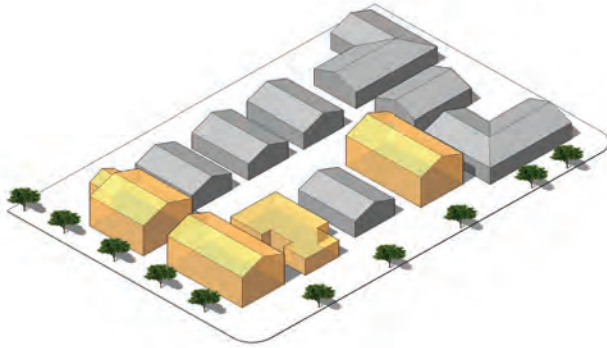

Residential building heights, massing, and setbacks should be responsive to the existing neighborhood

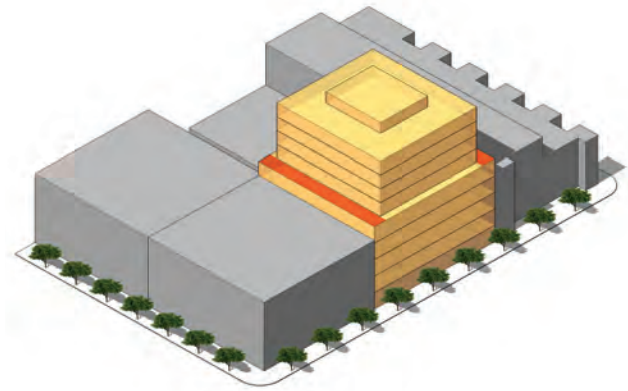

Upper story sideyard step backs should be incorporated

7.6.3.11 Building Materials

The use of high quality materials is essential for creating buildings that convey the sense of quality and permanence desired for the community. This includes the materials that are featured in the area's historic buildings such as plastered stucco, solid wood, tile, brick and decorative masonry. Accent materials used in entry ways, windows, and cornices must also be of the highest quality to ensure durability and character. Consider:

- A.** Encouraging the use of quality building materials and finishes in new developments that complement neighborhood character and reflect fine craftsmanship.
- B.** Using high-quality, durable materials in all projects. Quarry stone, terracotta, traditional decorative tile and textured masonry block, brick and solid wood are examples of quality materials. In taller buildings, use high quality materials at the street level to a minimum height of twenty feet where they are more visible to the public.
- C.** Designing new developments to respond in a compatible manner to the existing color, texture, and materials used on surrounding notable buildings.

- D.** Designing buildings with materials and colors that relate to masses and volumes. Changes in material or color should be designed with a change in the wall plane. Materials should wrap corners and continue at least 18 inches before another change in material. Compatible materials should be used on all four sides of the structure.
- E.** Unifying and providing visual interest to building exteriors through the use of building materials and colors. However, the number of materials and colors should be limited to promote a visual simplicity and harmony while helping to set off areas that appear to be different storefronts or building uses.
- F.** Adhering to color trends over neighborhood or architectural context is discouraged. Colors should be selected to correlate with traditional building styles as well as neighborhood aesthetics.
- G.** Avoiding the excessive use of metal, concrete, and concrete block as wall surfaces in residential projects.
- H.** Incorporate sustainable, local, and rapidly-renewable materials to the extent feasible and if compatible with overall design strategy.

7.6.3.12 *Building Transparency*

Ensure that mixed-use areas are vibrant, well-lit, and there is a clear connection between the activity of the pedestrian realm and commercial establishments and private residences. Transparency at the street level plays a significant role in supporting an active pedestrian environment by creating a direct connection between public and private realms and engaging the interest of pedestrians. Transparency refers to the amount of glazing (i.e., windows) on a building façade. Storefront windows activate and add visual interest to the pedestrian environment by displaying products and revealing activity within shops and restaurants. They also contribute to public safety by placing “eyes on the street.” Guidelines that apply to transparency include:

- A.** Encourage the use of glazing to activate building facades.
- B.** Incorporate generous windows and street-oriented glazing that provide a high degree of transparency on street-level facades in commercial and mixed-use areas.
- C.** Ensure that the street level façade is 60-75 percent transparent where retail or other community or active uses occur.
- D.** Utilize clear, non-reflective glass rather than opaque, translucent or reflective glass, which does not count towards the transparency ratio.
- E.** Design front doors of retail or other pedestrian-oriented ground-floor uses with windows that permit views into the establishment.

7.6.3.13 *Fenestration*

Ensure that the arrangement, proportioning, and design of windows, creates active building facades that are visually engaging and connect a building’s interior activities with the public realm. From the outside, windows provide a human scale to buildings, and animate facades with their varying sizes, patterns, and treatments. From the in-

side, they provide for natural light and views, and operable windows provide for natural ventilation. Due to their importance in building design, providing guidelines for fenestration is essential to achieving successful urban design. Utilize the following guidelines:

- A.** Design buildings with window patterns that contribute to superior architectural design.
- B.** Design and placement of windows should have character, style, and scale appropriate to the overall building design.
- C.** Group windows to establish rhythms across the façade and hierarchies at important places on the façade.
- D.** Include windows along all walls visible from the public realm to avoid blank walls.
- E.** Ensure that windows are not flush with the exterior wall surface.
- F.** Recess window glass a minimum of three inches from the exterior wall surface to add relief to the wall surface.
- G.** Use wainscoting and reveals to enhance the appearance of deep-set windows.
- H.** Allow for natural ventilation by designing all occupied rooms to have operable windows.

7.6.3.14 *Building Lighting*

Ensure visual interest and clarity by integrating pedestrian-scale lighting with signage, street numbering, and other features, such as public art. The primary purpose of illuminating buildings is to provide for security and pedestrian safety. Lighting is also used to enhance details of the front facade, and to illuminate plant materials and pathways in the landscaping. Known for their distinctive commercial areas and nightlife, various parts of National City employ lighting to promote commercial and entertainment activity. In primarily residential buildings, lighting is focused primarily on key entries and access paths with generally low levels

of exterior illumination. Thus, the manner in which it is illuminated is critical to maintaining community character, user comfort, and successful businesses. In general, the following policies apply to building lighting, which is distinct from the lighting of the public realm. These guidelines include:

- A.** Incorporate lighting that complements and enhances building design and reinforces neighborhood character.
- B.** Employ lighting to add drama and character to buildings and landscape, ensure public safety, and enhance nighttime activities.
- C.** Balance levels of illumination to be responsive to the type and level of anticipated activity without under-or over-illuminating. Generally, higher illumination is desired on buildings and areas with higher levels of night time use.
- D.** Select fixtures that complement building architecture and integrate lighting in to the whole of the building and project design.
- E.** Focus illumination on the front entryway, recessed entry ways, walkways, and garage areas of residential buildings.
- F.** Building addresses should be illuminated and clearly visible from the street at night.
- G.** Illuminate buildings and landscaping indirectly by concealing light features within buildings and landscaping to highlight attractive features.
- H.** Direct lighting to avoid light spillage on to neighboring properties.
- I.** Building-mounted lighting should be angled downwards or include cut-off shields.
- J.** Avoid unnecessary glare.
- K.** Use energy efficient lighting sources with warm white color and good color rendition.
- L.** Ensure that electric sources are concealed and not in conflict with architectural detailing.



Southwestern College's window placement contributes to the overall building aesthetic



Chamber of Commerce glass façade uses clear non-reflective glass creating a desirable street-level building transparency



Windows create pleasing rhythms in the facade of this multi-family building on 9th Street

7.6.3.15 Private Signage

Signs play a fundamental role in the community, especially in commercial areas. They facilitate local commerce by identifying where goods, services, and entertainment can be found. They also play a significant role in community character—contributing to either a more attractive and legible urban environment or one that is confusing, visually cluttered, and unattractive. In National City, a conflict exists between signs scaled for pedestrians versus signs scaled for motorists. In order to reinforce pedestrian orientation, the type, size, and placement of signs is important. The inclusion of attractive, distinctive, and noticeable signage that is complementary to neighborhood character is a primary goal of private realm building design. In residential areas, signage is only appropriate for use in multi-family projects where it is needed to identify a project or clarify wayfinding. Signage should:

- A.** Incorporate signage that complements building design and contributes to neighborhood character.
- B.** Design signs at a scale for pedestrian, rather than vehicular traffic.
- C.** Avoid locating signs more than 20 feet above the sidewalk or be higher than the building cornice line or streetwall height.
- D.** Construct signs of high-quality materials such as wood, metal, or stone.
- E.** Include messages that are simple and clear, and focus on business identification rather than advertising. (signs should generally include the name of the business and logo, with minimal additional text).
- F.** Limit signs on residential buildings to the name of the complex and the address.
- G.** Make name and address easily visible from the street to assist visitors and emergency vehicles and be illuminated to be visible after dark.
- H.** Design signs as an integral part of the building, consistent with architectural style, scale, materials, and color.



Wall sign- name plate flush mounted



Awning signs



Blade signs

- I. Encourage signs that use icons, symbols, or logos rather than words (e.g. shoe for a shoe store, a bicycle wheel for bike shop, etc.).
- J. Include primary access points to the complex and within the complex, as needed, to provide clear direction to visitors in entry signage.
- K. Conceal electrical conduit, tubing, conductors, transformers, mounting hardware, and other equipment.
- L. Identify all building and residential units using street numbers that are easily observed from the street.
- M. Encourage the following types of signs:
 - Wall signs
 - Window signs
 - Projecting or blade signs (oriented vertically or horizontally)
 - Band, panel or plaque signs (flush-mounted)
 - Printed signage on awnings or canopies
 - Marquee signs (theater projections)
 - Individual lettering (three-dimensional, flush-mounted, channel)
- N. Discourage the following types of signs:
 - Internally-illuminated acrylic box signs
 - Internally-illuminated vinyl awnings
 - Animated and rotating signs
 - Pole signs
 - Billboards



Marquee sign



Sandwich sign



Window sign



Band sign

7.6.4 BASE-BUILDING MATERIAL AND DESIGN REQUIREMENTS

The lower floors of a tall building are referred to as the base building. The role of the base building is to frame the street life, articulate entrances, and assist in the creation of an attractive and animated street scene that provides a safe, interesting, and comfortable pedestrian experience.

7.6.4.1 Street Wall Articulation

Ensure new buildings articulate their facades to add scale and visual interest to street walls as seen from the public realm. Accomplish this by using the following guidelines:

- A.** Vary and articulate building massing and façades to contribute to a fine-grained, pedestrian scale environment at the street level.
- B.** Reinforce the fine-grained pattern established by the underlying historic lot pattern.
- C.** Articulate the ground level façade to read as substantial change in the façade (i.e., provide a significant shadow line). In areas where a project is required to be built to the build-to line, use streetwall variation elements such as recessed store front entrances, sidewalk cafes, and pedestrian passages to create visual interest and to set up a scale that is typical of main street style storefronts, even when some businesses are likely to take up several of these scaled storefront modules.
- D.** Articulate elements at the second or third floor by including notched setbacks, by projecting bays and balconies.
- E.** Employ the use of vertical volumes (e.g., towers, gables, etc.) and changes in height to break up long facades, provide focal features, and highlight key locations (e.g., building entrances, entry to a paseo, street corners, etc.) by higher quality materials, fenestration, articulation of the planes and lighting focal points.

- F.** Avoid repeating the same wall surface design horizontally by more than a third of a lot face.
- G.** Combine changes in depth or horizontal plane with a change in material and character.
- H.** Associate changes in façade material or color with a change in plane or separated by a pilaster.

7.6.4.2 Ground Level Uses

Encourage ground level use and design of buildings that add to the vitality of the public realm. It is important that commercial, residential, and community uses actively engage the public street to promote vibrant commercial corridors. Do this through the use of the following guidelines:

- A.** Engage and activate the pedestrian realm through ground floor uses.
- B.** Encourage ground-floor uses that are active and pedestrian-oriented. Discourage uses that have low propensity for walk-in traffic, since they can rob the street of social activity.
- C.** Utilize floor-to-floor heights between 16 feet and 18 feet as an optimal height for commercial ground floors in mixed-use buildings.
- D.** Design ground-floor elevations for commercial uses to be level with the elevation of the adjacent public sidewalk.



Engage and activate the pedestrian realm

- E.** Design ground-floor residential uses within attached residential and mixed-use developments to provide a grade change of at least two to three feet from the public sidewalk to the first-floor residence to enhance the privacy of residential units.
- F.** Provide a direct at-grade access from the sidewalk for all commercial uses located at the street level. An entrance should be provided for each tenant street frontage exceeding 50 feet. Where such frontages exceed 100 feet, one entrance should be provided for each 100 feet of frontage or portion thereof. Separate pedestrian entrances for individual tenants should be at least 25 feet apart.
- G.** Provide a repeating pattern of at least three of the following building elements: color change, texture change, material module change and expression of a structural bay to provide visual interest at the ground floor level of building facades.
- H.** Provide the lobby for office, hotel, or other commercial buildings on the ground floor of the building, abutting the exterior, as well as arranged as a clearly defined architectural feature of the building.
- I.** Provide visually distinct entries to stores and ground-floor commercial uses from the rest of the building façade.
- J.** The use of scale, material selection, glazing, projecting/recessed forms, architectural details, color, and shade devices can all contribute to the visual interest of the ground floor uses and street environment.
- K.** Ensure that the design, materials and colors of all outdoor street furnishings complement the associated restaurant/café, including lighting, heat lamps, and tables and chairs. Any fencing or walls used to demarcate outdoor dining areas should be decorative, temporary, and should not be opaque.
- L.** Provide stoops and landscaping in front setbacks to provide a buffer between the sidewalk and the unit's living areas.

- M.** Ensure that a minimum of 25 percent of each street-facing, ground-level residential unit possess clear, non-reflective windows.
- N.** Identify each street-facing unit either on the door or the adjacent wall.

7.6.4.3 Privacy Treatments for Ground Floor Residential Use

Although it is important to link all ground uses to the street, including residential, it is also important to provide safety and privacy for these residential uses. This balance must include elements from the previous section along with the following guidelines:

- A.** Filter and screen views into private dwelling units with landscaping, but ensure views to street and open space are maintained for natural lines of sight and surveillance.
- B.** Provide landscaped streetscapes with generous setbacks for trees and plantings to maintain privacy.
- C.** Utilize open wrought iron or lath patterns on fencing or walls that allow visual penetration from the unit to the street while still providing a clear message that this is private space and you are not allowed access without permission.

7.6.4.4 Commercial-Residential Use Compatibility

Ensure commercial and residential uses are designed to have positive associations between walkability, transit access, and buildings that frame streets creating vibrancy. However, some commercial uses can have unwanted spillover effects on existing adjacent residential uses, or when located within mixed-use buildings. Components of the building program can instead be utilized to provide physical separation. Therefore, careful attention to the site plan and design detail of new commercial, institutional and mixed-use development is necessary to avoid or minimize unwanted spillover effects. Guidelines to consider include:

- A.** Incorporate measures to reduce the potential for conflicts (e.g., noise, fumes, light, etc.) between residential and non-residential uses in mixed use areas, especially in the neighborhood transition zones.
- B.** Buffer residential uses at the adjoining property line through installation of solid masonry walls and landscaping within required setbacks. In no case should the landscaped setback be less than 5 feet.
- C.** Solid walls should be between 5 feet and 8 feet high depending upon potential project effects on abutting residential properties.
- D.** Ensure that uses that may generate excess or more continuous noise front commercial streets where primary access, window openings and any permitted outdoor use can be located away from adjacent residential uses.
- E.** Building elements that generate less noise such as office space, storage areas, and parking should be located closer to residential uses.
- F.** Make sure that drive-through lanes that generate noise from speakers and patrons' vehicles to are designed to minimize noise effects on adjacent residential uses. Site planning should utilize building and parking arrangements to separate the drive-thru lane from adjacent residential uses. Measures such as directing speakers away from abutting residential uses, the addition of landscape buffers and decorative sound baffles should be used as appropriate to reduce noise.
- G.** Utilize parking levels or rooftops as appropriate when locating generators, exhaust vents, trash enclosures and other service equipment.
- H.** Contain and vent exhaust fumes away from adjacent residential uses as well as pedestrian areas such as sidewalks and plazas for odor-generating uses such as restaurants.

- I.** For mixed-use buildings, exhaust vents should not be located below the fourth floor and should be directed away from operable windows, air vents, and balconies within the building.

7.6.4.5 Articulation Requirements of Public Elevations

The base building should define and integrate with adjacent streetwall buildings, assist to achieve transition down to lower-scaled buildings and minimize the impact of parking and servicing on the public realm. Utilize these guidelines to improve compatibility:

- A.** Upper floor windows and other openings should be either square or vertically proportioned.
- B.** The base building should be located and designed to resolve the differences when existing setbacks are well-established, but vary on either side of a building site.
- C.** Stucco as a finish material should not be used within the first 12 feet of the building above sidewalk level.
- D.** Commercial buildings fronting onto the public realm should include a vertical feature or architectural expression of a type and character that calls attention to the store's location.

7.6.4.6 Transparency Requirements of Public Elevations

- A.** Provide multiple entries and transparent glazing to support active, street-related commercial uses. Consider:
- B.** Buildings with a ground floor commercial use should be glazed with a clear, non-reflective glass shopfront glazing system to no less than 70 percent of the first floor vertical and horizontal surfaces.

- C.** Buildings with a ground floor residential use should be glazed with a clear, non-reflective glass shopfront glazing system to no less than 50 percent of the first floor vertical and horizontal surfaces.
- D.** Windowsills may be no higher than 3 feet above the sidewalk level, or 5 feet above sidewalk level when the ground floor level is elevated above sidewalk level.

7.6.5 MID-BUILDING MATERIAL AND DESIGN REQUIREMENTS

The role of the mid-building is its higher elevation relationship with the block and district as it is lifted above the building base and has a relationship with its adjacent building elements. Often the mid-building represents the largest square footage of elevation and is generally the most prominent component in size as seen from a distance. However, since the viewing locations where the larger portion of the mid-building can be seen is at a greater distance, detail and building materials are not as important as design fenestration.

7.6.5.1 Mid-Building Material and Design Guidelines

Use the following guidelines for design of the mid-building:

- A.** Ensure upper floor windows and other openings are either square or vertically proportioned.
- B.** Openings above the first floor should be no less 50 percent of the total building wall area, with each Facade being calculated independently.
- C.** Ensure all residential dwelling units should be enhanced by outdoor living spaces such as balconies, verandahs and patios.
- D.** Design residential balconies to be an extension of interior living space and consider inset or partially inset balcony arrangements to offer greater privacy and be more comfortable.

- E.** Ensure that these elements be designed as an extension of the overall architectural concept.
- F.** Design enclosures for projecting balconies that face public streets to be comprised of an average of at least 40 percent open or transparent materials (perforated mesh, translucent glass, or open rail) from 18 inches above the balcony walking surface to the top of the balcony enclosure.
- G.** Design balcony arrangements and materials to control sunlight penetration that results in passive heat gain.
- H.** Design balconies to be a minimum of 100 square feet with a minimum dimension of 6 feet in one direction.
- I.** Ensure building wall materials will be combined on each facade horizontally with the heavier materials placed below lighter materials intentionally keeping the lighter materials on top.
- J.** Buildings wider than 50 feet should utilize a combination of simple or articulated parapets, alternating eaves or cornice line projections, or multiple front gables to break up the roofline into horizontal segments.

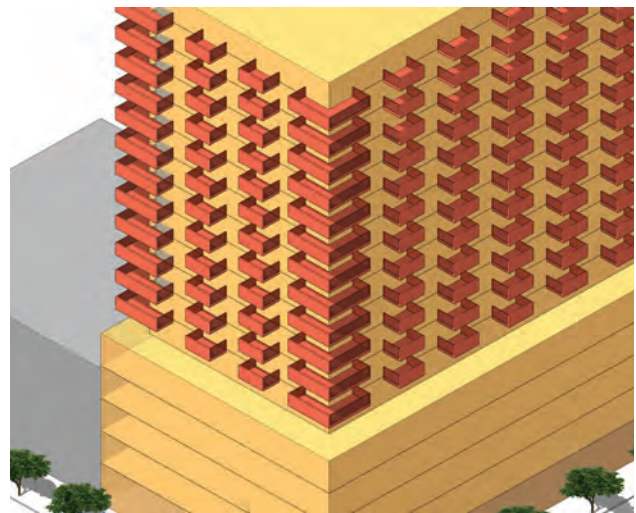

All residential building should have outdoor spaces, such as balconies and patios

7.6.6 UPPER-BUILDING MATERIAL AND DESIGN REQUIREMENTS

The silhouette created by building roof lines is an important component of community character whether it is a two-story commercial building viewed from the street frontage or a high-rise mixed-use building viewed from afar. Because of its prominence and background, massing and roofline are much more important than building materials and detail.

7.6.6.1 *Upper-Building Material and Design Guidelines*

Use the following guidelines for design of the upper-building:

- A.** Design the top of tall buildings to make an appropriate contribution to the quality and character of the city skyline.
- B.** Tall buildings tops should reinforce the supporting role of the building and subtly integrate with the overall tower design.
- C.** Articulate tall buildings tops with high-quality, sustainable materials and finishes to promote design excellence, innovation, and building prominence.
- D.** The tops of all buildings, including upper floors and roof-top mechanical or telecommunications equipment, signage, and amenity space, should be designed, primarily through tower massing and articulation, and secondarily through materials, to create an integrated and appropriate conclusion to the tall building form.
- E.** Roof mounted equipment should be setback and screened from view from adjacent thoroughfares Primary Frontage.
- F.** Solar panels that are attached to buildings should be integrated into the architectural design of the building.
- G.** Roof-top mechanical and telecommunications equipment, as well as signage, must be

well-integrated into the total building design to avoid detracting from the form and elegance of the top.

- H.** Rooftops need to accommodate servicing and life-safety requirements and mechanical areas need to be appropriately screened while still retaining a form that will be a distinctive and memorable contribution to the community's skyline.
- I.** Require that rooftops are designed in an expressive and contextual manner, with mechanical areas appropriately screened.
- J.** Use strong, attractively detailed cornices or parapets to define the roofline in buildings with flat roofs.
- K.** Screen and architecturally integrate all mechanical penthouses and stair towers in to the form of the building. Use materials to clad mechanical equipment and penthouses that complement the rest of the building.
- L.** Locate rooftop equipment so that it is not visible from streets or other public spaces. Mechanical penthouses or screens should be setback at least 5 feet from the building façade.
- M.** Consider potential views from surrounding taller buildings in rooftop design.
- N.** Green roofs and roof gardens or patios can be used to enhance rooftop appearance from surrounding buildings.
- O.** Buildings should screen window cleaning equipment, such as elevating platforms, rolling scaffolds, suspended scaffolds, boatswain's chairs, or ladders, from public realm view.

7.6.7 PARKING AREA / PARKING STRUCTURE GUIDELINES

The role of parking is essential to the success of many businesses and developments, but often detracts from site design and architectural focus. To facilitate walkability, parking should generally

be located behind buildings or under them to enhance the pedestrian quality of the frontage. This is critical in the "Main Street Type" Retail District as well as the Visitor and Educational District.

7.6.7.1 Off-street Parking and Access

Parking is a critical factor in both the aesthetic character and the economic stability of the community. To ensure success, downtown needs to not only ensure that adequate parking is provided to support proposed uses, but that the location and design of parking supports an attractive, pedestrian-friendly mix of uses. On-site parking should be placed on the interior of blocks or below ground to reduce its visual prominence, the potential for pedestrian/vehicle conflicts, and support the pedestrian-oriented character of the community. Similarly, the location of building elements related to service access, mechanical equipment, and utilities needs to be carefully designed to ensure functionality while minimizing adverse impacts. Generally, the objective is to make these required program elements as visually and physically unobtrusive as possible. You can accomplish this by doing the following:

- A.** Integrate off-street parking into the design of new mixed-use development.
- B.** Discourage new surface parking areas to accommodate permitted development intensities while maintaining an attractive pedestrian environment.
- C.** Locate the parking area behind buildings and on the interior of blocks where it is screened from public view when surface parking is used.
- D.** Include new curb cuts, preferably on side streets, only when there is no alternative means of site access.
- E.** Locate off-street parking in below-grade parking structures and on the interior of the block whenever possible.
- F.** Avoid parking as a visible ground-floor use.
- G.** Wrap parking garages adjacent to public streets with "linear" space for retail, commercial, or residential uses that activate the street frontage and screen parking from public view.
- H.** Design upper floors of parking that are visible from the street so that automobile and parking structure lighting is not visible from street level.
- I.** This design should reflect a level of articulation and design character consistent with the rest of the building façade.
- J.** Use mid-block alleys, where present, or shared driveways originated at block ends as primary entryway into parking and garages.
- K.** Minimize driveways and curb-cuts along the primary street frontage in order to reduce pedestrian/vehicle conflicts and impacts on street parking capacity.
- L.** Phase out existing curb cuts and driveways along retail streets as non-conforming properties are redeveloped and alternative access can be provided.
- M.** Include landscaping and lighting in all surface parking lots.
- N.** Treat parking areas as part of a sustainable site design strategy, incorporating elements such as permeable pavement, recycled or native materials, and climate-appropriate plants.
- O.** Recess, screen, and minimize the size of garage doors and service openings visible from public streets and public or private open space. Use high-quality doors and finishes.
- P.** Provide passenger loading and car sharing areas on private property for tall buildings which contain residential, hotel, or commercial and office uses.
- Q.** Provide pedestrian and cyclist access to and from parking areas that is clearly visible, well-lit, convenient, and easily accessible from the public realm street.



Parking structure is enhanced with an exterior screen/façade



Perforated metal panels partially veil parking area



Planted divider improves a parking structure facade

7.6.7.2 Screening

Not all parts of a site or development are considered to be positive. All edges of a project need to be considered. Even slightly seen edges may require screening. To assure the screening does not add negative views of a project, follow these guidelines:

- A.** Ensure fences and walls are used to prevent or discourage the public access to dark and unmonitored areas and/or dead-end areas.
- B.** Locate all utilities outside the public right-of-way within a building alcove, utility room, or landscaped area, and be fully screened from view of the public right-of-way.
- C.** Group and screen architecturally all mechanical equipment, appurtenances, and access areas within fully covered enclosures consistent with the overall composition of the building.
- D.** Ensure that access and service areas and utilities do not adversely affect the appearance of new development.
- E.** Locate service, loading, and storage areas away from public streets and spaces, preferably at the rear or interior of a development.
- F.** Provide service access to commercial and mixed-use buildings from alleys or, where an alley does not exist, from secondary streets, to the degree possible.
- G.** Screen service facilities and access from adjacent uses to minimize the potential for undesirable impacts.
- H.** Locate utilities and mechanical connections (e.g., back-flow preventers, utility boxes, etc.) on the building to minimize their visibility from public areas. Integrate facilities into the design of the building or site whenever possible. If located in the landscape, screen utilities and avoid exposed, free-standing elements.
- I.** Avoid free-standing vehicle ramps, loading areas, and garbage storage and collection areas or enclosures.

- J.** Ensure that in the absence of a building facade along any part of a frontage line, streetscreens should be built along the same vertical plane as the facade.
- K.** Maintain the building frontage bay rhythm and pattern for streetscreens
- L.** Use streetscreens to clearly define a lot's uninhabited space (parking area or civic space) fronting onto a primary thoroughfare.
- M.** Design streetscreens to be of a similar or complimentary design to the facade of buildings they abut.
- N.** Design streetscreens to be between three and a half (3.5) and six (6) feet in height.
- O.** Design streetscreens to be of similar design as adjacent hedge or fencing.
- P.** Locate ventilation shafts, grates, and other above-ground mechanical or site servicing equipment, away from the public sidewalk (especially the pedestrian clearway) and public or private open spaces.
- Q.** Locate back of house activities such as utilities, underground or within the building mass, away from the defined public realm and public realm view, ideally located on secondary street frontages or alleys.
- R.** Locate back of house activities such as loading, servicing, and delivery vehicle parking, underground or within the building mass, away from the defined public realm and public realm view, ideally located on secondary street frontages or alleys.
- S.** Utilities which are required to be located on primary street frontage must be located wholly on site and outside of the public right-of-way.





Patterned panel screening solution



Concealing building facade treatment



Decorative metal screen fence

7.6.7.3 Security Lighting and Lighting Spillover Prevention

Encourage lighting plans and specifications on projects to show the use of energy, including efficient lighting, solar power to fuel street lights, the removal of existing but unneeded lighting, use of automatic turnoff systems, and application of non-lighting alternatives such as clear signage and clearly painted roadway lines. Lighting control guidelines include:

- A.** Utilize materials in new development that will reduce light reflection and glare.
- B.** Utilize adequate, uniform, and glare free lighting, such as dark-sky compliant fixtures, to avoid uneven light distribution, harsh shadows, and light trespass onto adjacent properties.
- C.** Consider the use of artists for projects that involve lighting as a decorative element on a building or the inclusion of lighting elements such as public art.

7.6.8 BUILDING HEIGHT

Create an incentive program where additional height/floors can be realized as a bonus for providing public amenities (e.g. pocket parks, public parking) in identified Sub-Districts. An in-lieu fee could be considered where a project site is not in an optimal location to provide for a public amenity.

7.7 PUBLIC REALM DESIGN GUIDANCE

7.7.1 INTRODUCTION

All the spaces within the Specific Plan area fall into two categories of ownership—private or public. The private realm includes all areas owned by individuals, private entities, or corporations. The public realm includes all spaces within the public right-of-way encompassing sidewalks, parkways, bike lanes, and roadways. Typically associated with through-traffic, spaces within the public realm are sometimes overlooked and treated merely as functional vehicular corridors. In actuality, the high-visibility and large combined area of these spaces give them the potential not only to safely convey pedestrians, bicyclists, and vehicles from place to place but to provide public space, enhance the beauty and image of the urban environment, improve sustainable storm-water capture, and increase the economic potential of a city or area.

Two primary categories define the public realm as shown in Figure 7-10, the travel-way zone and the pedestrian zone. The pedestrian zone consists of pedestrian walkways and planted parkway areas. The travel-way zone includes on-street parking, bike lanes, vehicular travel lanes and other roadway elements. Proper balancing and interplay of these two zones is key to creating successful spaces within the public realm. Urban streets should meet the needs of motorized vehicles as well as cyclists and pedestrians in an equitable manner. The following text provides further definition and direction concerning the design of these two primary zones.

Figure 7-10: Public Realm Categories

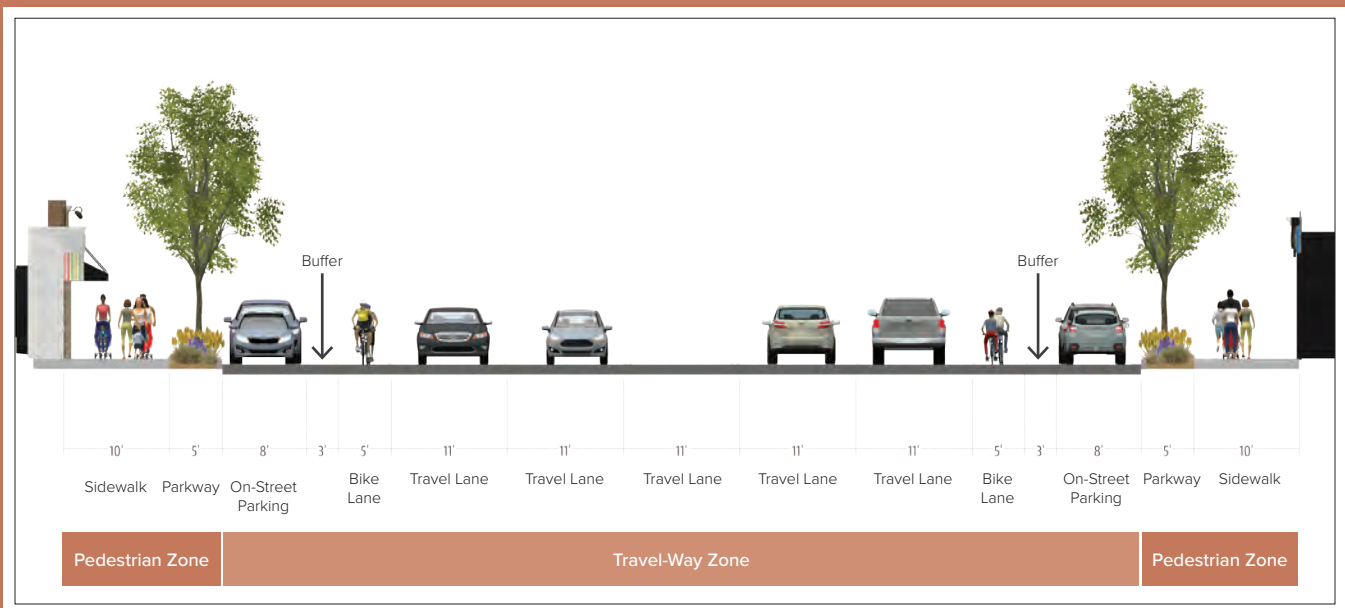

7.7.2 STREET TYPOLOGIES

To establish a legible street hierarchy throughout the Planning Area, a typology of street types is recommended as shown in Figure 7-11. Each street type is treated in a different manner as described below to provide functionality and aesthetics appropriate to the existing or envisioned street character and service level. See Section 7.7.6 Pedestrian Facilities and Section 7.7.7 Street Amenities for pedestrian zone guidelines pertaining to all street types. While the private realm design guidelines are applied per design district, public realm design guidelines are applied per street typology.

7.7.2.1 Main Streets Guidelines

Located near the center of downtown, these street segments prioritize educational, hospitality, and many retail uses. These streets are lined with pedestrian scaled storefronts, usually forming a continuous storefront façade. As most of downtown National City's primary destinations such as Southwestern College are located on these streets, they should balance the need for vehicular access as well as providing a safe and comfortable walking environment. Vehicular through-traffic should be given some priority, with sufficient travel lanes and parking areas added to serve retail uses, but adequate pedestrian crossings, public spaces, and facilities for those on foot and biking should also be provided. Guidelines to be used:

- A.** Locate most parking off-street in under or above ground parking structures. Parking lot entries and exits should be minimized and accessed from the rear of the lot or through alleyways to avoid potential conflicts with pedestrian walkways.
- B.** Accommodate bicycle use with in-street markings for Class II bike lanes, Class III bicycle routes, bike boxes, and by providing bike parking.
- C.** Provide walking spaces sufficient to accommodate the projected pedestrian level-of-service between the retail storefront streetwall and all street furnishings and amenities. Ideally, heavily used pedestrian walkways should provide a 14 feet and at a minimum 10 feet wide clear and unob-

structed path of travel. Refer to Table 7-1 for more information on sidewalk widths. In lower-use areas a minimum walkway width of 5' could be allowed if used in conjunction with parkway strips or other vegetated buffers and planter areas.

- D.** Accommodate any necessary outdoor displays and other special retail needs and uses or walkways. Maintain a clear walkway width of at least 5' where these features encroach into pedestrian areas and routes.
- E.** Avoid blocking commercial signage with street trees, lighting fixtures, or other amenities.
- F.** Consider adding gateway elements or monumentation with landscaped backdrops to signify entrance into districts within the Planning Area at key intersections and other locations.
- G.** Provide tree grates at all tree-wells to allow for heavier retail pedestrian traffic.

7.7.2.2 Commercial Streets Guidelines

These street segments are dominated by commercial uses including a diverse mixture of auto, thrift, and other store types. Areas with continuous storefront retail developments such as those discussed above are not included in this designation. Here the needs of the businesses and customers should direct the design strategy. Needs such as parking, building access, and storefront visibility should be considered and provided for. To support commercial streets properly, utilize the following guidelines:

- A.** Maintain service access to businesses for loading and unloading, waste disposal, transfer of goods, and other commercial purposes.
- B.** Encourage on-street, parallel, and angled parking to provide a buffer between pedestrians and vehicular traffic.
- C.** Provide direct and easy access by pedestrians from parking areas to business entries.
- D.** Screen parking areas and reduce glare from auto lots with appropriate tree and shrub plantings, fencing, or other means.

Figure 7-11: Street Typologies

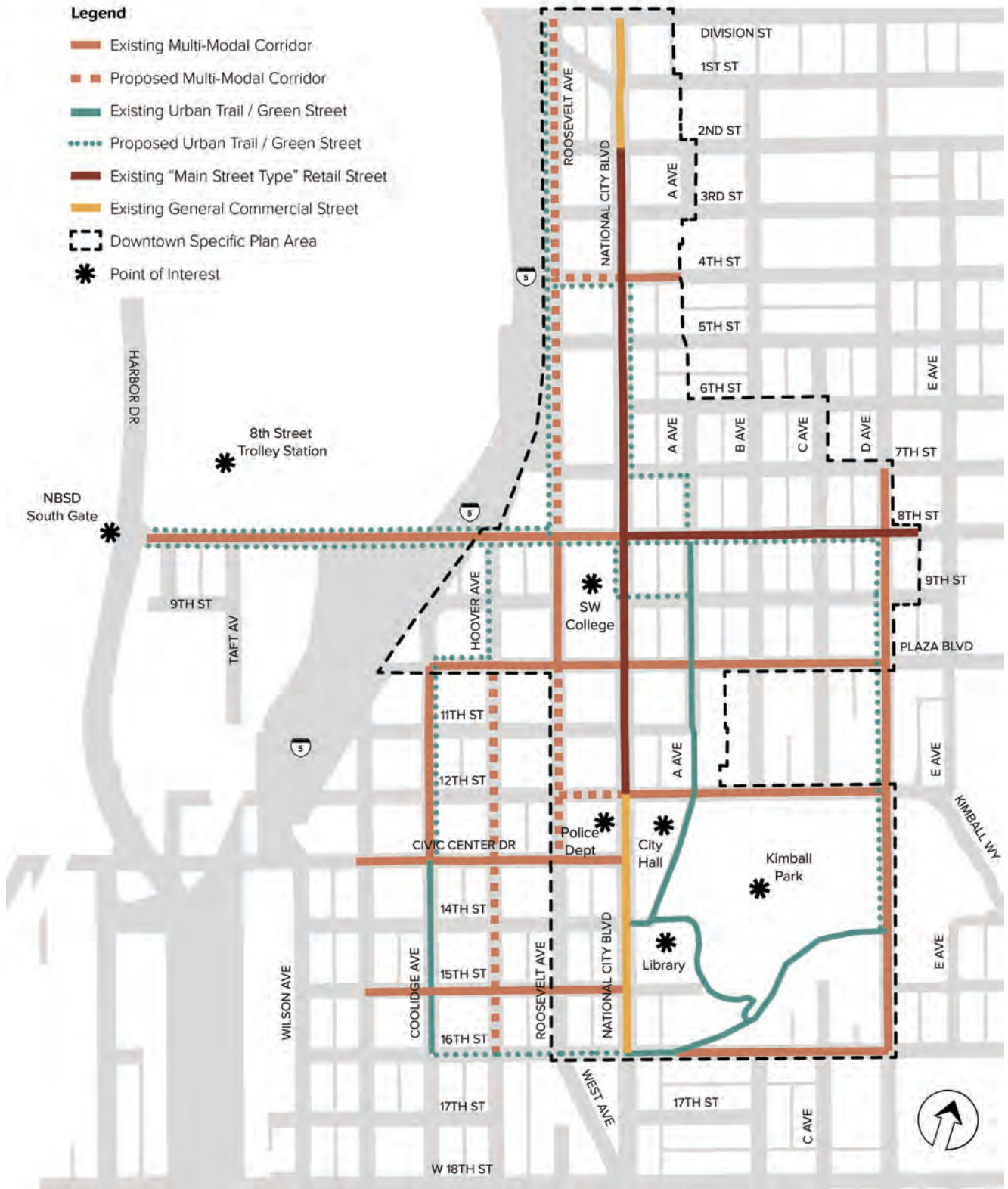

- E.** Avoid blocking commercial signage with street trees, lighting fixtures, or other amenities.

7.7.2.3 *Multi-Modal Streets Guidelines*

Envisioned as transportation corridors capable of fully supporting multiple forms of transportation, these street segments are proposed to provide facilities for cyclists and neighborhood electric vehicles (NEV) as well as standard automobiles and transit. Where appropriate these roadways should include separated bicycle travel lanes and special road markings to delineate NEV routes. These streets would also encourage pedestrian access to the downtown area. Guidelines to consider include:

- A.** Prioritize alternative travel methods including transit, cycling, NEV shuttles, and walking over the standard automobile through appropriate facility design and routing.
- B.** Delineate bicycle and NEV routes with separate lane systems, curbs, or road markings where possible.
- C.** Provide enhanced transit stops where appropriate with shelters, pedestrian amenities, art, and other amenities.
- D.** Consider reducing lane widths or removing travel lanes where appropriate to provide space for other modes of travel.
- E.** Create easy, clear, and direct pedestrian and cyclist access to the downtown core using appropriate signage, and special paving materials and site furnishings along the route.
- F.** Provide plaza and parklet spaces where possible for public use and enjoyment.
- G.** Limit truck and trailer parking along these roadways.

7.7.2.4 *Urban Trail/Green Streets Guidelines*

Streets in this category create urban trails that cater to “urban hikers,” providing them with safe,

visually rewarding routes throughout the city. In cases in which street segments in this category overlap with the Multi-Modal and Main Street categories, the Urban Trail route would be delineated with route markers, additional planting, and amenities. Compared to the other street categories, this street type would emphasize natural storm-water capture in planted areas and aim to create a lush urban forest through denser tree and shrub plantings. For a street to be green, apply the following guidelines:

- A.** Ensure pedestrian walkways are sized a minimum of 6 feet wide with a 10 feet preferred width.
- B.** Emphasize pedestrian safety through design devices such as curb extensions and crosswalks with special paving types.
- C.** Utilize pedestrian extensions, corner planters, or bulb-outs to reclaim excessively wide streets. Use in conjunction with pedestrian crossings as well as at the ends of angled and parallel parking spaces. All resulting planter spaces should be used to perform a storm-water infrastructure function.
- D.** Indicate urban trails with appropriate signage, site furnishings, and other pedestrian amenities.
- E.** Improve the hydrologic function of roadways by reducing and treating storm-water runoff, filtering pollutants, slowing water conveyance, and increasing water infiltration. Streets should incorporate permeable concrete, un-grouted pavers, and other ground treatments that allow for increased percolation and decreased runoff. See Section 7.7.4 Storm-water Basins & Infrastructure for more guidance concerning storm-water.
- F.** Ensure all planted areas including parkways, bulb-out planters, and medians perform a storm-water detention or flow-through function through strategies such as bio-swales, detention ponds, percolation trenches, structural soils, or other methods as specified in Section 7.7.4 Storm-water Basins & Infrastructure.

- G.** Emphasize large-canopy street trees along roadways. Plant street trees at spacing and density required to achieve canopy-to-canopy coverage. See Section 7.7.10 Street Trees for more information on street trees.
- H.** Consider adding a planted median or broad greenway on one or both sides of excessively wide streets to slow traffic and create greater plant coverage opportunities.

7.7.2.5 Residential Streets Guidelines

This street type includes all streets not categorized as Main, Commercial, Multi-Modal, or Urban Trail/ Green Streets. Typically, these streets support lower traffic levels and provide access to primarily residential areas. Pedestrian safety and traffic calming should be the primary concerns as residential roadways are often used as play areas by surrounding families. Residential streets can be best served using the following guidelines:

- A.** Utilize traffic calming strategies throughout. Widen parkways and create bulb-outs at intersections and mid-block crossings where possible to decrease vehicular speed and increase planter areas.
- B.** Limit the number and width of driveway curbs in residential areas to decrease pedestrian conflicts and disruption of sidewalk networks.
- C.** Increase asphalt reflectivity by repairing and sealing asphalt with chip seal, a coating that adds a layer of white aggregate on the surface of asphalt pours.



Existing main street



Existing multi-modal corridor



Existing green street



Existing residential street



Existing commercial street



Existing parallel parking



Existing parallel parking and curb extension



Existing angled parking

- D.** Limit use of concrete hardscape areas in front yard areas.
- E.** Encourage the use of large canopy trees along roadways

7.7.3 PUBLIC ON-STREET PARKING

Parking throughout downtown National City is a combination of on-street and off-street parking. On-street parking, located in the public realm, is an important component of a successful commercial and mixed-use district that benefits visitors, merchants, and residents, by providing convenient access to adjacent uses, buffering pedestrians from moving traffic, calming traffic speeds, and increasing pedestrian activity on the street. On-street parking can play an important role in reducing demand for private, on-site parking that can drive up housing costs and adversely impact building and site design. Streets with wide curb-to-curb widths offer an opportunity to provide more public parking, through the introduction of diagonal parking, which helps to calm traffic and reduce apparent street widths. This strategy has already been effectively used on 8th Street. It is important to ensure that on-street parking is aesthetically and functionally integrated into the design of the public realm.

On-street parking can be defined as either parallel, diagonal spaces, and angled parking. Both parallel and angled configurations are good solutions in the right context. Generally, parallel parking is better for higher volume streets with faster moving traffic and limited right-of-way width. Angled parking works better on slower, lower-volume streets that have ample right-of-way.

Angled parking can provide more on-street parking than parallel parking within the same length of curb, and it can be configured as either “head-in” or “back-in” type spaces. This is particularly desirable in retail areas that have “main street” type storefronts and want to generate as much street activity as possible. The disadvantages of angled parking are that it requires more street width, it can create sight distance problems for cars backing out, and it can slow traffic flow.

The use of back-in (reverse) angled parking can overcome the sight distance concerns, and because of this it is considered a safer solution for streets with bicyclists traveling adjacent to angled parking. However, it is a configuration that drivers are less familiar with so it requires some education and time for people to understand how it works.

7.7.3.1 On-Street Parking

For on-street parking, the City should:

- A.** Provide on-street parking on all streets to support adjacent uses and enhance pedestrian safety and activity.
- B.** Include primarily parallel on-street parking on high-volume arterial and collector streets and angled parking on lower-speed and lower-volume streets.
- C.** Limit driveway curb cuts to the extent possible to maximize the curb length available for on-street parking.
- D.** Provide driveway access on alleys or shared driveways where possible.
- E.** Explore opportunities to incorporate reverse angle (i.e., back in) diagonal parking to improve safety for bicyclists, calm traffic, and reduce conflicts with on-coming traffic. This is particularly appropriate in locations with generous street widths (50 feet or greater), where a narrower travel lane can accompany this configuration.
- F.** Avoid conflicts between front-in angled parking and marked bicycle lanes by providing a six-foot buffer. Bicycle lanes may be adjacent to the parking area when back-in angled parking is used.
- G.** Use metered parking in commercial areas to provide reasonable short-term parking for retail customers and visitors while discouraging long-term resident and employee parking.
- H.** Restrict time limits of 30 minutes or less to areas reserved for special, short-term, high-turnover parking such as passenger loading, convenience stores, dry cleaners, etc.
- I.** Limit parking to a maximum of 2 hours where turnover of parking spaces is important to support nearby retail business.
- J.** Design parking space widths depending on the land use context and thoroughfare type, and the anticipated frequency of parking turnover. The preferred width of a parallel on-street parking lane is 7 feet.
- K.** Incorporate plantings into on-street parking areas to contribute to the visual character of the street and reduce the apparent width of the street and vehicular travel speeds. This includes:
 - “Tree islands” to be included within the parking lane at regular intervals along the block to reduce uninterrupted lengths of on-street parking.
 - Landscaped curb extensions at each end of the block.
- L.** Provide on-street motorcycle parking in prominent, well-lit locations.
- M.** Stripe motorcycle parking bays perpendicular to the sidewalk in the on-street parking lane.
- N.** Place bike corrals in the parking lane in retail areas where pedestrian activity is heavy and sidewalk space limited to include bicycle parking.
- O.** Use bollards to define bike corrals to protect bicycles and cyclists.

7.7.4 STORM-WATER BASINS & INFRASTRUCTURE

Development has historically created large areas of impermeable surfacing in the urban environment causing environmental concerns in most municipalities in California. These include problems such as aquifer depletion, excessive surface runoff, flooding, erosion, and the pollution of rivers and other waterbodies. Regional agencies such as the Regional Water Quality Control Board have established strict regulations and policies that local agencies must follow. To comply with these policies, National City should adopt best management practices for storm-water capture and infrastructure for its public spaces and streets.

A sustainable storm-water management system that captures and stores storm-water runoff could not only solve an array of environmental issues but also contribute to a greener urban environment that is more attractive to citizens and visitors. Runoff requirements should be integrated with urban forestry efforts throughout National City to boost water quality improvements, decrease runoff, and reduce the heat island effect. The aesthetic benefits of these strategies could simultaneously enhance National City's image and improve its economic success.

The two most established techniques for reducing the surface flow of water in urban areas, reducing impermeable surfacing, and slowing or capturing the surface runoff in landscape or other catchment devices, are both addressed in the following guidelines. For further information, consult the City's storm-water standards manual.

7.7.4.1 Reducing Impermeable Surfacing

The biggest factor affecting the quantity of runoff is the permeability of surfaces. To lower runoff quantity and to improve water quality, consider:

- A.** All existing and proposed paved areas should incorporate permeable landscaped areas or a permeable surfacing material such as pervious asphalt/concrete, un-grouted pavers, grass pavers, tree grates, stabilized decomposed

granite, or cobble to increase storm-water infiltration, sub-surface flow and aquifer recharge. Existing and future pervious asphalt and concrete surfacing should be cleaned periodically through dry-vacuuming and pressure washing treatments to preserve the water infiltration capacity of the surfacing. Without this periodic maintenance, the infiltration rates of permeable surfacing can decrease by 25 percent or more.

- B.** Existing parkways and other landscaped areas should be preserved and expanded wherever possible.
- C.** A permeable surfacing material should be used along gutters, at road edges, and as part of parking lot and street parking surfacing where possible.
- D.** Street widths should be decreased where traffic flows allow to decrease impermeable surfacing and provide opportunities for planted areas, bike lanes, and other amenities. Pedestrian extensions, corner planters, bulb-outs, and other pedestrian-friendly features can also be used to reclaim excessively wide streets at crossing points and intersections.
- E.** Cluster development strategies which encourage the focusing of impervious surfaces and maximization of open space and permeable areas should be encouraged in new construction and development.

7.7.4.2 Capturing Surface Runoff

Runoff should not be considered as a nuisance to get rid of. Water has beneficial uses, so it should be captured and used. Consider:

- A.** All planted areas including parkways, bulb-out planters, and medians should perform a storm-water detention or flow-through function through strategies such as bio-swales, detention ponds, percolation trenches, structural soils, or other methods.

- B.** Curb-openings should be provided at all planted areas adjacent to the roadway to allow water to flow into the planter spaces. Cobble or another dissipation strategy should be implemented at all curb-openings to decrease the energy of the water entering the planted areas and to reduce the displacement of mulch and other debris in planted areas.
- C.** Soil levels in planted areas to be used for storm-water filtration should be graded flush with the finish grade of adjacent paving surfaces or lower to promote the entry and flow of storm-water. Excessive soil grade changes in planter areas should be avoided to prevent trip hazards.
- D.** Existing soils in storm-water collection landscape areas should be analyzed for percolation rate, quantity of organic material, and other characteristics that could affect infiltration. If required, the soil should be amended or replaced with soil capable of storing and infiltrating the water volumes expected from the chosen design storm event and able to support the plant species chosen for the planter area.
- E.** An engineer or other qualified professional should be consulted to determine if sub-surface drains or other artificial methods are required to effectively drain planted areas during the design storm event.
- F.** The use of structural soils, Silva Cells, Filterra treatments, and other runoff capture and filtration devices in conjunction with permeable surfacing should be encouraged.
- G.** Capturing storm-water in underground cisterns or other storage containers for reuse as planter irrigation water should be encouraged.
- H.** Storm-water capture areas should be celebrated through interpretive signs and other methods at key pedestrian gathering spaces and where appropriate.
- I.** Encourage the use of street trees which decrease the impact of rainwater, absorb rainfall, and release it back into the atmosphere through evapotranspiration.



Storm-water bioretention areas along 8th Street



Curb extension and bioswale on Plaza Boulevard



Permeable paving on A Avenue

- J.** Planted filtration areas should utilize hardy, low-maintenance plant species capable of withstanding both inundation and low-water conditions. In selecting plant species, those with a high capacity to capture and treat pollutants, nutrients, and other contaminants should be prioritized.

7.7.5 BICYCLE FACILITIES

An important solution for lowering vehicle miles traveled and to reduce greenhouse gases must include bike improvements.

7.7.5.1 Bicycle Facilities Guidelines

For bicycle facilities, the City should:

- A.** Provide low-stress, comfortable bicycle facilities to increase transportation options for National City residents. National City's Bicycle Master Plan has identified a network of streets within National City that should incorporate different bicycle facilities in the future.
- B.** Facilities to be considered include: designated bicycle lanes, sharrows, cycle tracks, and bicycle boulevards. In locations where high-speed and high-volume vehicle traffic make cycling dangerous, traffic calming elements should be implemented. See Chapter 4 Circulation for more information and guidelines relating to the recommended bicycle network and facilities for the Planning Area. See Section 7.7.7 Street Amenities for guidelines concerning type, placement, and spacing of bike amenities.
- C.** Roads with heavy traffic or difficult conditions for cyclists should still be improved. However, if this is unfeasible, parallel streets with lower stress factors should be considered.
- D.** Consider the need for bike parking facilities in all new projects and developments.



Bike lane on Roosevelt Avenue



Sharrow on Plaza Boulevard



Bike box at the intersection of 4th Street and National City Boulevard

7.7.6 PEDESTRIAN FACILITIES

Pedestrian facilities represent the system of walkways designed to carry people walking between destinations within the city. Generally located within the public right-of-way, these routes wrap the perimeter of the city blocks providing access to street frontages, educational and recreational areas, and private residences. Although pedestrian facilities are primarily associated with sidewalks and parkways, they also include street crossing amenities such as crosswalks and bulb-outs as well as public plaza and mini-park areas where space allows. Together these four pedestrian facilities form the bulk of the pedestrian experience. For guidelines relating to other features occurring within the pedestrian facilities zone such as street furnishings, paving types, and street trees see Section 7.7.7 Street Amenities and Section 7.7.10 Street Trees.

7.7.6.1 Pedestrian Walkways

Pedestrian walkways or sidewalks consist of three sub-areas or zones called the Encroachment Zone, the Walkway Zone, and the Furnishing Zone. These sub-areas are illustrated in Figure 7-12, and suggested widths for pedestrian walkways in the five downtown zones are indicated in Table 7-1.

The **Encroachment Zone** is the area of the sidewalk adjacent to the building and shall be available for outdoor dining, sidewalk signage, street furniture, non-affixed planters, and outdoor merchandizing.

The **Walkway Zone** is the area of the sidewalk with a continuous, unobstructed, accessible, paved area dedicated to pedestrian movement along the public right-of-way. Walkways are required on all frontages.

The **Furnishing Zone** is the area of the sidewalk between the face-of-curb and the Walkway Zone utilized for street lights, utility poles, street furniture, outdoor dining, and street trees.

Figure 7-12: Typical Walkway Zones



Table 7-1: Walkway Width per District

District	Preferred Width	Minimum Width
"Main Street Type" Retail	14 feet	10 feet
Visitor / Education Village	14 feet	10 feet
General Commercial	10 feet	6 feet
Neighborhood Transition	10 feet	6 feet
Civic Center	10 feet	6 feet

The broader pedestrian walkway or sidewalk zone may be entirely public or a combination of public and private property to support an active and well-furnished pedestrian environment and to achieve a more desirable wider sidewalk. Adequate space between the front of the building and adjacent street curbs to safely and comfortably accommodate pedestrian movement, streetscape elements, and activities related to commercial uses and outdoor dining should be directed by the following guidelines:

- A.** Improvements in the public right-of-way should stress public safety using CPTED (Crime Prevention Through Environmental Design) strategies. These would include the clear delineation of public and private spaces and maintaining clear sightlines to prevent blind corners and other low-visibility areas throughout.
- B.** Features located in the public realm should be durable, requiring little to no maintenance and assume minimal City funding for repairs or improvements.
- C.** Provide stable and smooth walking surfaces, minimum walkway widths, required vertical clearances, clear passing and turning areas, curb ramps, accessible furnishings and amenities, and all other features stipulated by ADA regulations and the current CBC (California Building Code) for all pedestrian walkways.
- D.** Meet the minimum widths required by City ordinances and suggested in Table 7-1 for the five downtown districts. Widen sidewalks where they do not meet these minimum/suggested requirements using concrete or paver bands. In areas where increasing sidewalk width is difficult because of existing development, require either acquisition of additional space by narrowing the street cross-section or require new development to implement increased setbacks.
- E.** Determine the appropriate level-of-service for each pedestrian walkway and ensure ultimate width will accommodate the expected pedestrian traffic while also meeting minimum width requirements for each district as shown in Table 7-1. Appropriate walkway width can range from 6 feet wide in some districts to 14 feet wide in active retail areas.
- F.** Identify and remove or relocate existing obstructions to pedestrian travel such as utilities, signs, or projecting plant material to provide a minimum 48 inch clear path of travel for all walkways.
- G.** Ensure outdoor dining areas and other business-related elements in retail and commercial areas provide a minimum 5 foot wide walkway space beyond the Encroachment Zone area.
- H.** Encourage infill of gaps in existing sidewalk and other pedestrian pathways to form a continuous and convenient network.
- I.** Create pedestrian networks that provide direct lines of travel between destinations and discourage shortcutting through private or planted areas.
- J.** Ensure that the placement of buildings, fences, and other permanent structures or improvements do not obstruct future routes between spaces. Connectivity between residential, commercial, educational, and recreational areas should be encouraged through appropriate walkway design.
- K.** Provide direct pedestrian access to building entrances and street frontage from pedestrian walkways and on-street parking. Avoid routing pedestrians through surface parking lots to get to businesses and other destinations.
- L.** Minimize points of conflict between pedestrians, cyclists, and motorists such as intersections, parking lot entry/exits, and driveways where possible.

- M.** Maintain clear sight triangles and sight distances appropriate to the design speed of the relevant streets where pedestrian, bicycle, and vehicular routes intersect. Avoid obscuring sightlines through proper placement and design of building projections, signs, landscaping, and other elements. Clearly confer the right-of-way to the pedestrian through grade separation, articulated pavement, signage, or other means.
- N.** Provide a buffer between pedestrian walkways and vehicular areas where space allows to protect walkers and establish a visual and spatial cushion. Use design elements such as on-street parking, street trees and furnishings to create or reinforce this buffer.
- O.** Consider street closures where traffic levels may allow the closure to reclaim space for pedestrian walkways, plaza, and parklet spaces.
- P.** Preserve historic pedestrian walkways and their design character including widths and materials, incorporating and highlighting them in new developments where possible. All historic sidewalk stamps and sandstone curbing should be preserved where possible.
- Q.** Implement a consistent paving type, scoring, and pattern to establish a unified character in National City’s individual districts and streets.



Walkways on 8th Street



Walkways on National City Boulevard between 8th Street and Plaza Boulevard

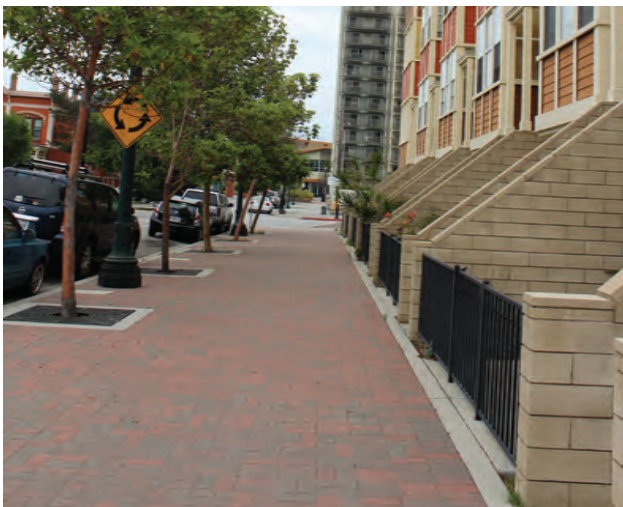

Walkways on 9th Street



Walkways on National City Boulevard



Curb extension on 8th Street



Curb extension and median refuge on Plaza Boulevard



Mid-block crossing on National City Boulevard

7.7.6.2 Street Crossings

Street crossings are the most safety challenged portions of streets. To improve safety, consider the following:

- A.** Use highly visible and slip-resistant paving materials, striping, and other pavement treatments within the street crossing area. Crossing areas should be visually distinct from the street and should clearly outline the zone for pedestrians versus vehicles.
- B.** Distinguish and bring attention to pedestrian crossings wherever possible by changing the material of the crossing area to decorative pavers, colored or stamped concrete, or another contrasting paving type approved by the City.
- C.** Install marked ladder-style crosswalks at each leg of all controlled intersections. At all other intersections, the need for crosswalks should be analyzed by an engineer taking factors such as design speed, length of crossing, and sight distances into account. Crosswalks should be provided where considered necessary to ensure pedestrian safety by the analysis.
- D.** Consider using raised crosswalks and/or intersections where possible based on the design speed and character of the intersecting roadways to slow traffic and prioritize pedestrian movement across the intersection.
- E.** Consider installing pedestrian-activated flashing pavement markings and signals at heavily used and/or significant crosswalks.
- F.** Provide curb ramps meeting all ADA and CBC guidelines at all intersections in a paired configuration.
- G.** Provide crossing count-down signals at all traffic lights.
- H.** Minimize the crossing distance at pedestrian crossings using curb extensions, median refuges, or other devices where possible. This

could also be achieved through the elimination of turning lanes, reduction of number or width of vehicular lanes, and by reducing the turning radius of curb returns at intersections.

- I. Design curb extensions to meet minimum curb radius standards as determined by the City or engineer. The radius provided should allow for the operation of street-sweeper vehicles, drainage of storm-water, and adequate clearance for larger trucks turning using the outer travel lane. Where used at transit stops, curb extensions should allow for a full-length transit bulb so buses can easily merge back into the travel lane.
- J. Provide mid-block crossings where large block lengths create a significant pattern of pedestrian jaywalking towards the middle of a block.
- K. Mark mid-Block crossings with ladder-style striping and HAWK beacon signals or a similar flashing device. ADA curb-ramps should be provided at each end of the crossing along with curb extensions and other traffic calming measures if recommended by the City or engineer.

7.7.6.3 Parkways & Planted Areas

Landscaping and street furnishings are the two most visible factors in creating great streets. To make streets both functional and positive community assets, consider these guidelines:

- A. All proposed pedestrian walkways should incorporate planted parkways or tree wells where space and other conditions allow.
- B. Existing parkways and planted areas should be preserved and paved areas replaced with planted areas where possible to increase the overall permeability and green cover of pedestrian zones.
- C. Parkways designed for shrubs and groundcovers should be minimum three feet wide, and minimum five feet wide where intended for trees to ensure adequate room for healthy root and overall plant growth. A 10 foot wide planting space is preferred when installing large tree species.

- D. Plant material including trees, shrubs and groundcover should be hardy, drought-tolerant, and capable of withstanding frequent disturbance and abuse with minimal maintenance.
- E. Plant material should be selected and placed so that at mature width and height it does not project into pedestrian or vehicular travel lanes or exhibit an overgrown habit that could create spaces in which persons or objects could be concealed.
- F. Poisonous, thorny, or spiny plant species should not be used where they would be accessible to the public. Plant species prone to create excessive leaf or other litter should also be avoided.
- G. Plant material should be used to conceal utilities, reduce glare from parking areas, and perform other screening functions where applicable.
- H. Provide street trees regularly for shade and weather protection. Plant and maintain street trees per all relevant City ordinances. See Section 7.7.10 Street Trees for more information concerning street tree spacing and other relevant guidelines.
- I. Shrub and groundcover planting should not reach heights greater than 36 inches at maturity except in medians and when used as focal points in plaza and other key public spaces.



Planted parkway on A Avenue

7.7.6.4 Public Plazas & Open Space

Downtowns are most memorable and appreciated when the streets provide a variety of open spaces and gathering places. Include the following:

- A.** Create mini-plazas in the public right-of-way where possible prioritizing key street corners, intersections, building entrances, and spaces at which streets terminate or tee into another street. Consider using curb extension and mid-block crossing bulb-out areas as part of proposed plaza spaces.
- B.** Establish a focal point in each public plaza and parklet space using an art piece, planted area, unique amenity, or other object of interest.
- C.** Define a clear edge to each public space type signaling entrance into a special-use zone using ground plane, vertical, overhead or a combination of these element types.
- D.** Support both active and passive uses in public gathering spaces.
- E.** Encourage dining opportunities including open-air cafes, kiosks, pushcarts, and food trucks.
- F.** Provide bike parking, seating, and planting areas to further define and support the design of public plaza spaces. Encourage movable seating where possible.



Morgan Square public open space

7.7.7 STREET AMENITIES

Street amenities provide an important service in the urban environment by adding detail, interest, and providing usable, pedestrian-scaled elements along pedestrian routes. Furnishings can create a more humanized environment and support the larger design themes and hierarchies established by street networks through appropriate styling, placement, and furnishing types. Beyond their aesthetic purposes, street furnishings also provide many practical functions such as encouraging biking with bike racks, appropriate trash disposal with receptacles, pedestrian gatherings at seating clusters, and enhancing safety and visibility through lighting. To establish a successful commercial, recreational, and educational downtown core that is attractive to visitors and locals, these elements are essential.

To limit costs to the City and maximize the effectiveness of the street furnishings implemented in National City, furnishings should be placed and concentrated as shown in Figure 7-13: Streetscape Design Segments, and Table 7-2: Recommended Street Improvements. Using this as a design outline for the placement of the street furnishings will ensure that they support the overall design for districts, street trees, and art placement while also highlighting key streets such as National City Boulevard and "A" Avenue.

7.7.7.1 General Guidelines

General guidance on street furnishings include:

- A.** Street furnishings should be placed in a rhythmic and continuous fashion so there are no large gaps between amenities that would present a lack of available services for pedestrians. Development and construction creating cohesive applications of street furnishings on complete city blocks should be prioritized and incentivized.
- B.** Street furnishings should not impede pedestrian flow by creating obstructions or hazards and should be well coordinated with the placement of artwork, trees, and other amenities.



Existing street light wayfinding sign



Bike rack on 8th Street



Street amenities along 8th Street

- C.** Where possible and appropriate, place street furnishings between pedestrian walkways and vehicle thoroughfares to create a visual and safety buffer.
- D.** Street furnishings should encourage a more convenient and attractive walking experience for pedestrians.
- E.** All street furnishings should be well-crafted, durable, low-maintenance, vandal-resistant, and compatible with the design aesthetic established by the existing light standards, art elements, and city culture.
- F.** All street furnishings which could be reasonably removed or stolen should be mounted to the paving surface where possible with stainless steel or other corrosive resistant fasteners as recommended by the furnishing manufacturer.
- G.** Street furnishing placement and character should comply with the guidelines specified for each amenity type in the following text.

7.7.7.2 Recommended Street Furnishings

Street furnishings provide function as well as continuity in public spaces. See guidelines below for specific model numbers and other information pertaining to the furnishings and amenities referred to in Table 7-2 Recommended Street Improvements. All street furnishing and amenity models, manufacturers, colors, and specifications can be altered or replaced with approved equivalents at the City's discretion.

- A.** Name: Double-Acorn light standard
 Manufacturer: Southcoast Lighting
 Model #: BCSTE2439-8A11RF-16-2K118-100WLED
 Color: Black - RAL BLK or Green - RAL 6028 (see Table 7-2)
 Finish: Powdercoat
- B.** Name: Double-Pendant light standard
 Manufacturer: Southcoast Lighting
 Model #: BCSTE2439-8RS14F-23-CA-AL-H(M)-72-2-(2)K805 120WLED
 Color: Black - RAL BLK or Green - RAL 6028 (see Table 7-2)
 Finish: Powdercoat



Standard Double-Acorn light standard on 8th Street



Mission Double-Pendant light standard on 8th Street



Single-Acorn light standard on 9th Street



Heritage Single-Acorn light standard on "A" Avenue



Concrete seat-wall with organic pattern



Standard Bench by Dumor Incorporated



Heritage Bench by Victor Stanley



Standard litter receptacle



Heritage litter receptacle

- C.** Name: Single-Acorn light standard
Manufacturer: Southcoast Lighting
Model #: BCSTE1827-5A11RF-10-K118-100WLED
Color: Black - RAL BLK or Green - RAL 6028 (see Table 7-2)
Finish: Powdercoat
- D.** Name: Heritage Single-Acorn light standard
Manufacturer: Southcoast Lighting
Model #: BCTUS1037-4A11RS-10-LA983-46WLED
Color: Black - RAL BLK
Finish: Powdercoat
- E.** Name: Concrete Seat-Wall
Manufacturer: Custom or per developer
Model #: NA
Color: Integral Earthy Tone
Finish: Formliner or other texture / pattern
- F.** Name: Standard Bench
Manufacturer: Dumor Incorporated
Model #: 19-60-AR
Color: Black - RAL BLK or Green - RAL 6028 (see Table 7-2)
Finish: Powdercoat
Note: Include optional center armrest
- G.** Name: Heritage Bench
Manufacturer: Victor Stanley
Model #: CBF-12
Color: Black - RAL BLK
Finish: Powdercoat
- H.** Name: Standard Receptacle
Manufacturer: Dumor Incorporated
Model #: 158-22SH-FTO
Color: Black - RAL BLK or Green - RAL 6028 (see Table 7-2)
Finish: Powdercoat
- I.** Name: Heritage Receptacle
Manufacturer: Victor Stanley
Model #: FC-12
Color: Black - RAL BLK
Finish: Powdercoat

- J.** Name: Standard Bike Rack
Manufacturer: Victor Stanley
Model #: BRQS-101
Color: Black - RAL BLK or Green - RAL 6028
(see Table 7-2)
Finish: Powdercoat
Note: Use surface-mount option



Standard bike rack by Victor Stanley

- K.** Name: Heritage Bike Rack
Manufacturer: Victor Stanley
Model #: BRBS-103
Color: Black - RAL BLK
Finish: Powdercoat
Note: Use surface-mount option



Heritage bike rack by Victor Stanley

- L.** Name: Art Bike Rack
Manufacturer: ARTS Center
Model #: NA
Color: Custom
Finish: Custom
Note: Bike racks may vary as determined by City and ARTS Center

- M.** Name: Standard Bollard
Manufacturer: Reliance-Foundry
Model #: R-7576
Color: Black - RAL BLK or Green - RAL 6028
(see Table 7-2)
Finish: Powdercoat



Custom art bike rack created by the ARTS Center

- N.** Name: Heritage Bollard
Manufacturer: Southcoast Lighting
Model #: BOL225-NL-8BL
Color: Black - RAL - BLK
Finish: Powdercoat



Standard bollard



Heritage bollard



Concrete planters serve as a pedestrian buffer

- O.** Name: Concrete Planter
 Manufacturer: Custom or per developer
 Model #: NA
 Color: Integral Earthy Tone
 Finish: Formliner or other texture / pattern

- P.** Name: Standard Tree Grate
 Manufacturer: South Bay Foundry
 Model #: D0060-SQ or D006096
 Color: Black - RAL BLK or Brown - RAL 8028
 (see Table 7-2)
 Finish: Powdercoat
 Note: Larger rectangular grate (model D006096) preferred where space allows

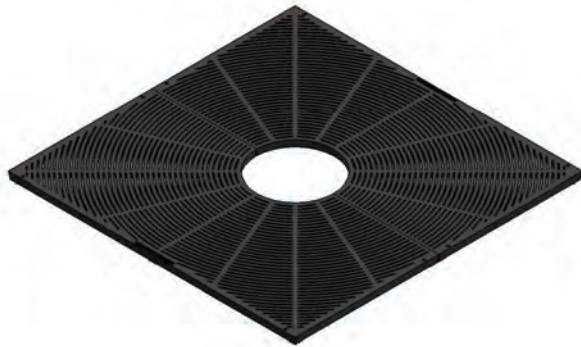

Standard tree grate by South Bay Foundry

- Q.** Name: Heritage Tree Grate
 Manufacturer: South Bay Foundry
 Model #: D2260-SQ or D226096
 Color: Black - RAL BLK
 Finish: Powdercoat
 Note: Larger rectangular grate (model D006096) preferred where space allows

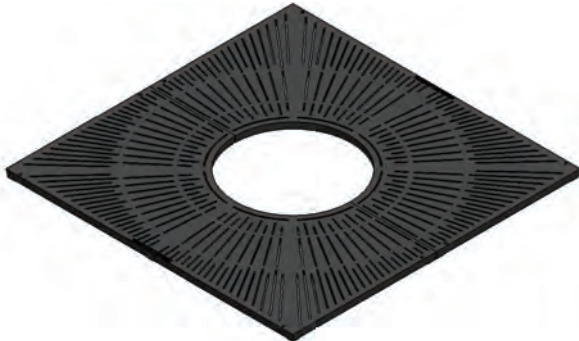

Heritage tree grate by South Bay Foundry



Existing green double-acorn street light with banners



Existing black single-acorn street light



Existing green standard bench on 8th Street

7.7.7.3 Lighting

Lighting is important for safety and function but also to provide character. Consider the following:

- A.** Lighting should be encouraged at all street intersections but particularly on streets designated for lighting on Figure 7-13: Streetscape Design Segments.
- B.** Light standards and other lighting types should be spaced to provide consistent lighting levels that meet minimum brightness guidelines for pedestrian safety.
- C.** All light receptacles should be scaled to the pedestrian maintaining a reasonable height not to exceed 15 feet.
- D.** Lighting design should prioritize the illumination of pedestrian walkways and spaces over streets and parking lots.
- E.** Light fixtures should minimize light spill onto adjacent properties and should use dark sky compliant features to decrease light pollution.
- F.** The light quality provided by all light receptacles should be subtle not garish, contributing to a sense of security and comfort while also meeting minimum recommended brightness levels.
- G.** Lighting fixtures should be energy efficient using LED, solar, or other strategies to ensure maximum conservation of energy and power.
- H.** All electrical conduit, sleeving, and mounting hardware should be visually minimized through undergrounding or other low-profile installation techniques.
- I.** Electrical conductors, transformers and other electrical boxes should be installed in vaults flush with finish grade where possible, wall-mounted, or screened with decorative fencing, hedging or other masking device.

7.7.7.4 Seating

Seating should not be provided on all streets. In retail areas or other areas of high pedestrian use implement the following guidelines:

- A.** Seating opportunities should be focused in areas where pedestrians commonly congregate such as restaurants, educational facilities, and transit stops.
- B.** Seating nodes should be placed in a sociopetal fashion to encourage interaction and in sheltered or protected areas where possible. Use planting areas and street trees to create a backdrop or to otherwise support the seating node configurations.
- C.** A minimum of 2 benches should be provided per block in each design district as shown in Table 7-2: Recommended Street Improvements. Spacing should be consistent except where use-areas suggest a greater density of seating.



Sociopetal seating arrangement

7.7.7.5 Litter Receptacles

Litter can be reduced when the following guidelines are used:

- A.** Trash and recycling receptacles should be placed with increased density at areas of highest pedestrian use to accommodate corresponding waste generation levels in those areas. Key locations include intersections, transit stops, building entrances, and seating areas.
- B.** Consider choosing split-stream litter receptacles with compartments for both trash and recycling items to reduce the required number of receptacles in an area. Where separate trash and recycling receptacles are used, place receptacles close together to encourage pedestrians to utilize the correct bin.
- C.** Receptacles should be fitted with lids that prevent rainwater from entering the trash or recycling compartments.



Seatwall at the National City Education Village

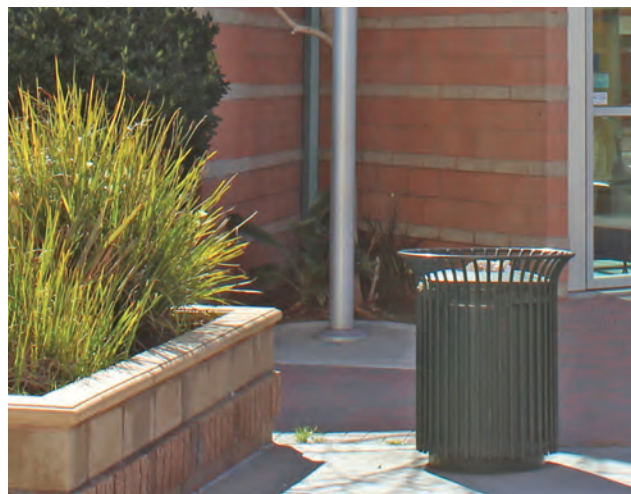

Urban litter receptacle

7.7.7.6 *Bicycle Parking*

Lack of parking facilities is a large problem to cyclists. Consider the following:

- A.** Placement of bicycle racks should encourage the convenience and use of biking and transit routes.
- B.** Bicycle racks should be placed so the full length of parked bikes remains clear of pedestrian and motorist pathways as well as seating and other use areas.
- C.** All bicycle racks should be clearly visible to cyclists from the street and from adjoining buildings and use-areas.
- D.** A minimum of 2 bike racks with parking capacity for a minimum of 4 bikes each should be located on both sides of the street on every block. Spacing and number of bike racks per block should be consistent throughout the city.
- E.** When new development occurs, a study should be performed to determine whether more than the minimum number of bike racks should be required.
- F.** Property owners should be encouraged to replace parking spaces with multiple bike parking spaces or bike corrals where appropriate.
- G.** Bike racks should be designed to provide a secure stand that will prevent the theft of bicycles and keep them from tipping over or becoming tangled with other bicycles.

7.7.7.7 *Bollards*

Bollards control traffic but can also set character. Bollards should be determined by the following:

- A.** Safety bollards should be placed along the edges of plazas, sidewalks, bulb-outs, and other pedestrian spaces where vehicular intrusion is a concern. Bollards should also be placed along edges as a decorative statement where deemed appropriate as currently applied on A Avenue at the historic Brick Row structure.
- B.** Where necessary removable bollards should be implemented to allow for emergency vehicular access or to provide access during special events.



Bike parking nook



Removable bollards at the intersection of A Avenue and Plaza Boulevard

7.7.7.8 Planters

Planters can provide visual relief to flat walkways that are often too consistent. Consider:

- A.** Decorative planters should be placed for maximum effect at areas of high pedestrian use and congregation.
- B.** Planters should be used to highlight seating nodes, intersections, building entrances or facades, and to create an aesthetic buffer between pedestrians and motorists.
- C.** Where possible planters should be connected to existing automatic irrigation systems or fitted with slow-release watering systems to minimize maintenance.

7.7.7.9 Tree Grates

When it is not possible to have open planters on the street, consider tree grates that can be regarded as walkable areas, and should follow these guidelines:

- A.** Tree grates should be used in areas of high pedestrian use where walking and gathering space is limited and tree wells could present a tripping hazard. Planting strips and tree wells should be encouraged instead of tree grates in residential, low-intensity use areas.
- B.** Tree grates should provide an opening for the tree with a minimum 12" diameter. All other decorative openings in grates should not exceed ¼ inch and should meet all ADA recommendations.
- C.** The space between tree grates and finish grade should be filled with ¼ inch or larger gravel to limit debris accumulation.
- D.** The design of tree grates should be coordinated with the aesthetic of other street furnishings and city elements.
- E.** Grates that provide options for tree guards, decorative lighting, and auxiliary power should be prioritized.



Seating with planters



Existing tree grate on 8th Street

7.7.7.10 Paving

Paving can be monotonous or chaotic. Well design spaces should consider:

- A.** Where decorative pavers are recommended in Table 7-2: Recommended Street Improvements, decorative pavers or bricks should be applied in 25 percent of the paving surface area. The decorative pavers could be applied in large fields at important node spaces, in decorative bands, or in other ways as indicated by the developer or designer.
- B.** Where colored concrete is recommended in Table 7-2: Recommended Street Improvements, integrally colored concrete should be installed in 75 percent of the paving surface area. The colored concrete should highlight key walkways and nodes and be coordinated with any decorative paver colors and patterns in the area.
- C.** Where scored grey concrete is recommended in Table 7-2: Recommended Street Improvements, decoratively scored concrete in a standard grey color should be installed in 75 percent of the paving surface area. The scoring of the concrete should be used to indicate special-use areas and to create paving detail through patterns and banding. All scoring should complement and enhance any decorative paver patterns in the area.
- D.** Where grey concrete is recommended in Table 7-2: Recommended Street Improvements, standard grey concrete should be installed in 100% of the paving surface area. The concrete should be installed so that control and expansion joints are regularly spaced and concrete pours are divided into equal rectilinear sections. All jointing should align with existing joints in adjoining concrete pours and building edges and corners where possible.
- E.** All paving materials should be City approved and should complement the context including adjacent paving on private property, the architectural treatments of the surrounding buildings, and the design of other significant elements.

- F.** Paving types should meet minimum standards for slip-resistance and should not create trip hazards. To prevent lifting and elevational differences between concrete pours, new concrete pours should be doweled into existing concrete panels.
- G.** Paving types that allow water percolation such as pavers and permeable concrete should be encouraged to promote groundwater recharge and lower runoff levels.
- H.** Paving coloration and surface texture should fall within a range of solar absorption / reflectivity that limits both excessive heat gain and glare.



Colored concrete in an earthy-tone



Scored concrete used with pavers and tree grate

7.7.7.11 Parking Meters

Parking meters have evolved. Consider:

- A.** Multi-space and pay-and-display parking meters should be implemented to minimize the number of meters required and to increase usable space in pedestrian walkways and spaces.
- B.** Meters should be coordinated with the design of the other street furnishing elements and should be given a black powdercoat or equal finish.

7.7.7.12 Newspaper & Magazine Racks

If not provided, newspaper organizations are often allowed to use their own racks. To avoid this, use these guidelines:

- A.** Racks should be located near existing racks in well-organized groupings at intersections, transit stops, and other areas where pedestrians commonly gather
- B.** Racks should never be chained to trees, street signs, or other utility poles.

7.7.7.13 Public Utilities

To avoid housing utilities degrade the built environment, consider these guidelines:

- A.** Whenever possible, utilities should be undergrounded to reduce visual impacts and vertical obstructions. Undergrounding should economize space to maximize room for street-tree planting.
- B.** Manholes, vaults, and other utility access points should be located outside of pedestrian walkways in private parcel areas.
- C.** When located above grade, utilities should be placed in a well-organized fashion outside of pedestrian walkways. These utilities should be screened from view with fencing, planting, or other means if possible.



Multi-space parking meter











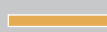

Organized grouping of newspaper and magazine racks

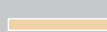

Single newspaper stand with multiple publications

Figure 7-13: Streetscape Design Segments

Streetscape Design Segments			Design Guideline District				
Symbol	Street	Limits	"Main Street Type" Retail	Visitor/Education Village	General Commercial	Neighborhood Transition	Civic Center
Main / Commercial Streets							
	8th St.	National City Blvd. - D Ave.	✓				
	National City Blvd.	Division St. - 2nd St.			✓		
	National City Blvd.	2nd St. - 12th St.	✓	✓			
	National City Blvd.	12th St. - 16th St.			✓		
Green Streets							
	9th St.	A Ave. - D Ave.	✓			✓	
	A Ave.	7th St. - National City Blvd.	✓			✓	✓
Multi-Modal Streets							
	7th St.	Roosevelt Ave. - D Ave.	✓	✓		✓	
	8th St.	Hoover Ave. - National City Blvd.		✓		✓	
	Plaza Blvd.	Interstate 5 - D Ave		✓		✓	
	12th St.	Roosevelt Ave. - D Ave.	✓			✓	✓
	Civic Center Dr.	Roosevelt Ave. - National City Blvd.			✓	✓	✓
	Roosevelt Ave.	National City Blvd. - 16th St.	✓	✓	✓	✓	✓
	D Ave.	7th St. - Plaza Blvd.	✓			✓	

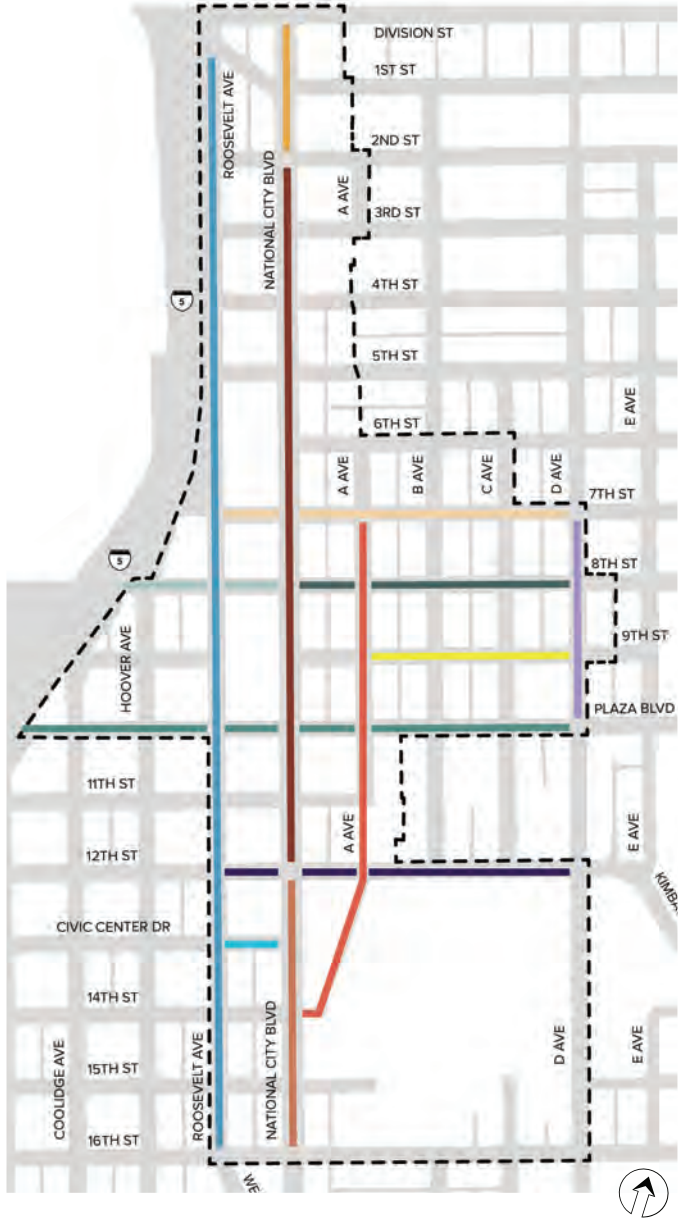

Table 7-2: Recommended Street Improvements

Street	Limits	Light Standard	Bench	Litter Receptacle
Main / Commercial Streets				
8th St.	National City Blvd. - D Ave.	Double-Acorn Color: Green	Concrete Seat-Wall Color: Earthy Tone	Standard Receptacle Color: Black
National City Blvd.	Division St. - 2nd St.	Double-Acorn Color: Black	Standard Bench Color: Black	Standard Receptacle Color: Black
National City Blvd.	2nd St. - 12th St.	Double-Acorn Color: Green	Concrete Seat-Wall Color: Earthy Tone	Standard Receptacle Color: Green
National City Blvd.	12th St. - 16th St.	Double-Acorn Color: Black	Standard Bench Color: Black	Standard Receptacle Color: Black
Urban Trail / Green Streets				
9th St.	A Ave. - D Ave.	Heritage Single-Acorn Color: Black	Heritage Bench Color: Black	Heritage Receptacle Color: Black
A Ave.	7th St. - National City Blvd.	Heritage Single-Acorn Color: Black	Heritage Bench Color: Black	Heritage Receptacle Color: Black
Multi-Modal Streets				
7th St.	Roosevelt Ave. - D Ave.	Single-Acorn Color: Black	Standard Bench Color: Black	Standard Receptacle Color: Black
8th St.	Hoover Ave. - National City Blvd.	Double-Pendant Color: Green	Concrete Seat-Wall Color: Earthy Tone	Standard Receptacle Color: Black
Plaza Blvd.	Interstate 5 - D Ave	Single-Acorn Color: Black	Concrete Seat-Wall Color: Earthy Tone	Standard Receptacle Color: Black
12th St.	Roosevelt Ave. - D Ave.	Single-Acorn Color: Black	Concrete Seat-Wall Color: Earthy Tone	Standard Receptacle Color: Black
Civic Center Dr.	Roosevelt Ave. - National City Blvd.	Double-Acorn Color: Green	Standard Bench Color: Black	Standard Receptacle Color: Black
Roosevelt Ave.	National City Blvd. - 16th St.	Double-Acorn Color: Black	Concrete Seat-Wall Color: Earthy Tone	Standard Receptacle Color: Black
D Ave.	7th St. - Plaza Blvd.	Double-Acorn Color: Black	Standard Bench Color: Black	Standard Receptacle Color: Black

Table 7-3: Recommended Street Improvements (Cont.)

Street	Limits	Bike Rack	Bollard	Planter
Commercial Streets				
8th St.	National City Blvd. - D Ave.	Art Bike Rack Color: Custom	Standard Bollard Color: Black	None
National City Blvd.	Division St. - 2nd St.	Standard Bike Rack Color: Black	Standard Bollard Color: Black	None
National City Blvd.	2nd St. - 12th St.	Standard Bike Rack Color: Green	Standard Bollard Color: Green	Concrete Planter Color: Earthy Tone
National City Blvd.	12th St. - 16th St.	Standard Bike Rack Color: Black	Standard Bollard Color: Black	None
Urban Trail / Green Streets				
9th St.	A Ave. - D Ave.	Heritage Bike Rack Color: Black	Heritage Bollard Color: Black	Concrete Planter Color: Earthy Tone
A Ave.	7th St. - National City Blvd.	Heritage Bike Rack Color: Black	Heritage Bollard Color: Black	Concrete Planter Color: Earthy Tone
Multi-Modal Streets				
7th St.	Roosevelt Ave. - D Ave.	Standard Bike Rack Color: Black	Standard Bollard Color: Black	None
8th St.	Hoover Ave. - National City Blvd.	Art Bike Rack Color: Custom	Standard Bollard Color: Black	None
Plaza Blvd.	Interstate 5 - D Ave	Art Bike Rack Color: Custom	Standard Bollard Color: Black	None
12th St.	Roosevelt Ave. - D Ave.	Art Bike Rack Color: Custom	Standard Bollard Color: Black	None
Civic Center Dr.	Roosevelt Ave. - National City Blvd.	Standard Bike Rack Color: Black	Standard Bollard Color: Black	None
Roosevelt Ave.	National City Blvd. - 16th St.	Art Bike Rack Color: Custom	Standard Bollard Color: Black	None
D Ave.	7th St. - Plaza Blvd.	Standard Bike Rack Color: Black	Standard Bollard Color: Black	None

Table 7-3: Recommended Street Improvements (Cont.)

Street	Limits	Tree Grate	Paving
Main / Commercial Streets			
8th St.	National City Blvd. - D Ave.	Standard Tree Grate Color: Brown	Decorative Pavers & Scored Grey Concrete
National City Blvd.	Division St. - 2nd St.	Standard Tree Grate Color: Black	Decorative Pavers & Grey Concrete
National City Blvd.	2nd St. - 12th St.	Standard Tree Grate Color: Black	Decorative Pavers & Colored Concrete
National City Blvd.	12th St. - 16th St.	Standard Tree Grate Color: Black	Decorative Pavers & Scored Grey Concrete
Urban Trail / Green Streets			
9th St.	A Ave. - D Ave.	Heritage Tree Grate Color: Black	Decorative Pavers & Colored Concrete
A Ave.	7th St. - National City Blvd.	Heritage Tree Grate Color: Black	Decorative Pavers & Colored Concrete
Multi-Modal Streets			
7th St.	Roosevelt Ave. - D Ave.	Standard Tree Grate Color: Black	Grey Concrete
8th St.	Hoover Ave. - National City Blvd.	Standard Tree Grate Color: Brown	Decorative Pavers & Scored Grey Concrete
Plaza Blvd.	Interstate 5 - D Ave	Standard Tree Grate Color: Black	Decorative Pavers & Scored Grey Concrete
12th St.	Roosevelt Ave. - D Ave.	Standard Tree Grate Color: Black	Decorative Pavers & Scored Grey Concrete
Civic Center Dr.	Roosevelt Ave. - National City Blvd.	Standard Tree Grate Color: Black	Grey Concrete
Roosevelt Ave.	National City Blvd. - 16th St.	Standard Tree Grate Color: Black	Decorative Pavers & Scored Grey Concrete
D Ave.	7th St. - Plaza Blvd.	Standard Tree Grate Color: Black	Grey Concrete

7.7.8 SIGNAGE

A cohesive sign network in the downtown region could significantly improve wayfinding in the area while also setting off certain districts as significant or distinctive, and establishing a branding scheme for these districts through unique color, font, and other sign design character choices.

The current signage and wayfinding package for the downtown region was prepared by Blik in conjunction with Kimley Horn. Reference this document for monument, gateway, directional, banner, and interpretive sign design, construction and fabrication notes, mounting details, and other detailed signage information. The guidelines, maps, and recommendations below recognize this existing sign package and expand on its sign layout and guidance in some areas.

7.7.8.1 General Guidelines

Follow these basic guidelines:

- A.** Coordinate location of all signage with regulatory signs, site furnishings, street trees, and other elements within the public right-of-way, so that signs retain a high visibility and contribute to an orderly pattern of arrangement.
- B.** Size gateway monuments and signs to match the scale of the roadway or plaza-space they accompany. Signs serving a pedestrian walkway or area should be scaled and oriented to the pedestrian not vehicular traffic.
- C.** Construct signs of durable, high-quality materials such as wood, metal, or stone.
- D.** Conceal electrical conduit, tubing raceways, conductors, transformers, mounting hardware, and other equipment related to signs within the Planning Area.
- E.** Encourage the following types of signs:
 - Wall signs
 - Window signs

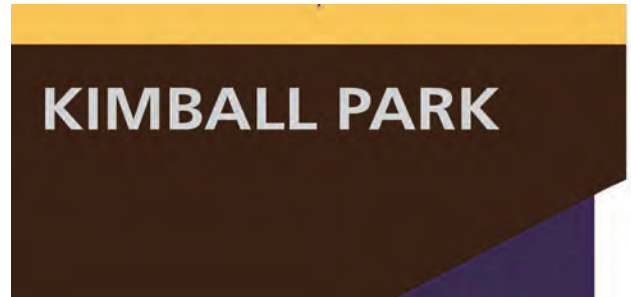

Arrival Monument Sign



Neighborhood Gateway Sign



Wayfinding Banners (Double & Single)



Street / Traffic Light Directional Signs

Figure 7-14: Downtown Signage Plan



- Projecting or blade signs (oriented vertically or horizontally)
- Panel or plaque signs (Flush-mounted)
- Printed signage on awnings or canopies
- Individual lettering (three-dimensional, flush-mounted, channel)

F. Discourage the following types of signs:

- Internally-illuminated acrylic box signs
- Internally-illuminated vinyl awnings
- Wind-activated signs
- Animated and rotating signs
- Pole signs
- Billboards

7.7.8.2 Public Sign Guidelines

Signs should be guided by:

- A.** Place all signs per the signage package prepared by Blik and Kimley Horn summarized on Figure 7-14: Downtown Signage Plan.
- B.** Directional and gateway signs should identify all key historic, cultural, civic, and shopping destinations and facilities. These would include schools, parks, libraries, police stations, and other significant buildings in the downtown area. See Figure 2-2 for the key structures and destinations within the Planning Area.
- C.** Provide signs directing motorists to parking areas, and place address identification signs at entrances to parking lots and structures.
- D.** Place signs in parking lots and structures to orient users to the downtown area and show nearby transportation facilities. These signs should not advertise for adjacent businesses.
- E.** Provide pedestrian-scaled signage at important pedestrian walkway entrances. Signs along pathways should make pedestrians aware of activities adjacent to and at termination points of the walkway.

F. Incorporate historical interpretive signage, where appropriate, to enhance the pedestrian experience.

G. Design and construct signs to conform to the City's Sign Ordinance and the signage package prepared by Blik and Kimley Horn. Ensure design continuity of signage and implementation of an overall branding theme throughout the downtown region utilizing the design character, fonts, and sizes established by the signage package.

7.7.8.3 Gateway Monument Guidelines

To be most effective, monument should:

- A.** Utilize gateway monumentation within the right-of-way to mark entry into Downtown National City at all key entrance points identified in Figure 7-14: Downtown Signage Plan. Entrance points at freeway offramps should be given special attention and design detailing. Consider enlarging gateway signs proposed by Blik's signage package.
- B.** Introduce gateway elements at key neighborhood or commercial district entries to reinforce neighborhood or district identity. Ensure that this local neighborhood monumentation does not compete in scale or visibility with the entry gateway monumentation located at the entrances to the overall downtown region.



Directional sign used with other sign types



Directional sign mounted on street light



Banners in National City with downtown graphic

7.7.9 PUBLIC ART

National City’s unique relationship with the ARTS (A Reason To Survive) Center located on 12th Street effectively positions the community to make art an integral part of the character and feeling of the downtown area. Already the ARTS Center has contributed to giving the city its own unique flair through projects such as the Stormwater Art Wall on “A” Avenue and the bike racks placed along 8th Street and elsewhere. The success of these initial art projects confirms that well-placed art pieces that relate to their immediate and regional context can have a positive impact on neighborhood character while also improving wayfinding, complementing the pedestrian experience, and encouraging tourism and the use of public spaces throughout the downtown area.

For the purposes of integrating public art pieces in the downtown region three functional categories of artwork should be considered. These categories or types of art include *art nodes*, art corridors, and art intersections. These categories of art reflect how art pieces are viewed and experienced and can include a diverse array of art types. Art nodes indicate public plaza or other pedestrian-oriented spaces to be used for the location of art pieces best displayed at close range, and viewed from all-sides by pedestrians and vehicles moving slowly or stopped. Morgan Square with its decorative arches and plaza spaces located adjacent to Southwestern College together form an example of an art node. An art corridor is a street or pedestrian walkway lined or marked by regular art installations meant to be experienced in a linear and sequential fashion. The art wall on “A” Avenue and the butterfly sculptures on 12th Street are good representations of corridor artwork.

Finally, art intersections represent intersections provided with artistic paving or other treatments. Together these three categories of art should be purposefully implemented in National City’s downtown to improve the image of the city and highlight important streets using available spaces in the public right-of-way. The recommended lay-

out and arrangement of these art types is shown in Figure 7-15: Public Art Plan. Art that goes outside of these categories and locations should also be encouraged, but should follow the guidelines presented below to best establish a successful public environment and to create a hierarchy of prominence and importance among vehicular and pedestrian routes.



The ARTS Center



Example of an art node



Example of decorative intersection paving type



Example of corridor art on "A" Avenue

Figure 7-15: Public Art Plan

- Legend**
- ★ Art Node
 - Art Intersection
 - Art Corridor
 - ⬜ Downtown Specific Plan Area

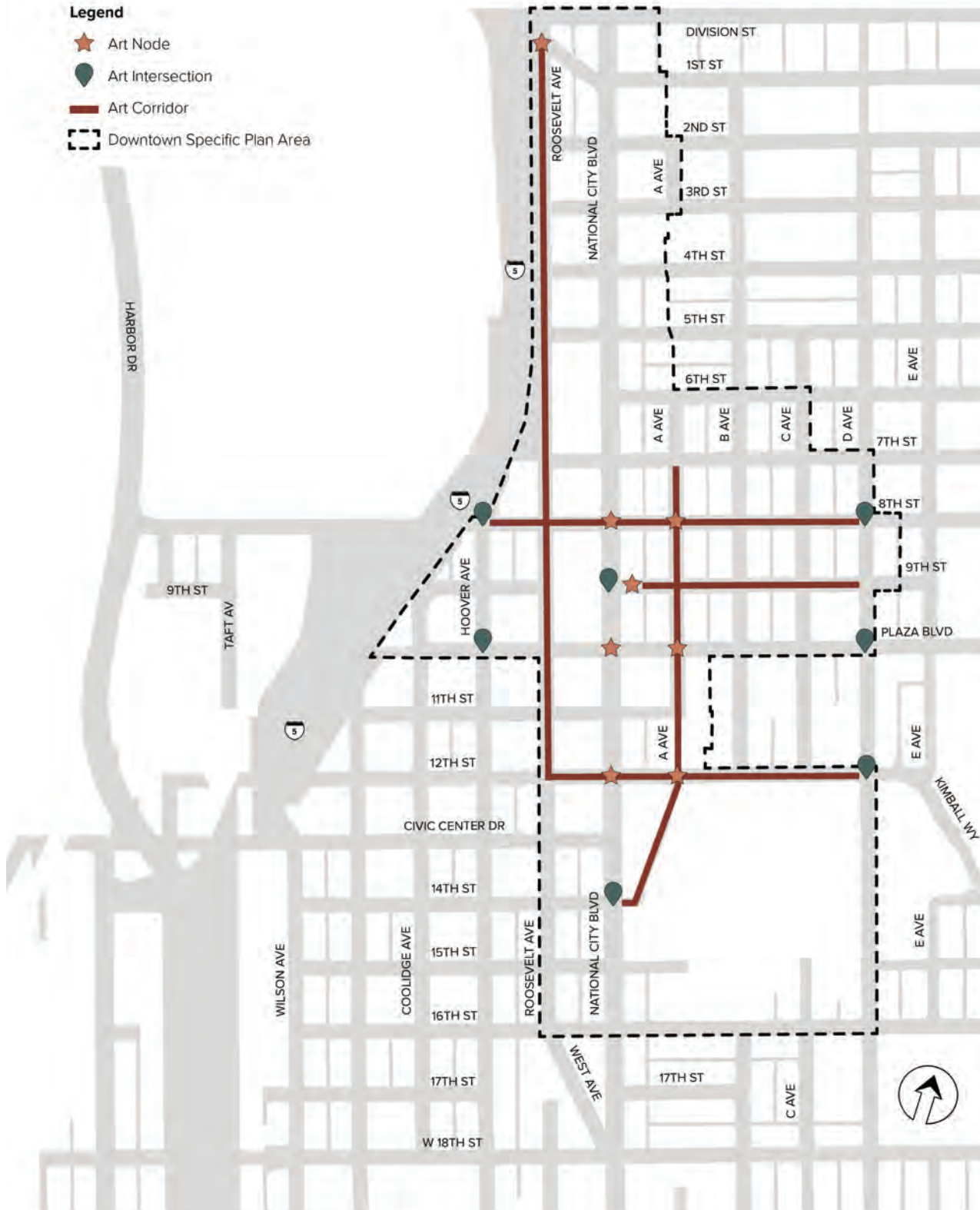

7.7.9.1 Public Art Guidelines

For new City funded projects, two percent of the overall budget shall be allocated for public art. One percent of overall budget for new, private developments shall be allocated for public art.

For public art guidance, please consider the following:

- A.** Artwork should be placed to mark key nodes, intersections and streets, following the recommended layout presented in Figure 7-15: Public Art Plan. While art should be encouraged on streets and in areas not presented in this exhibit as well, the placement and types of art should reflect and support the hierarchy and levels of prominence outlined by the exhibit.
- B.** Art nodes and nodes closer to the heart of the Planning Area should be given special attention, detail, and emphasis. Art elements should decrease in prominence as they occur further from the central downtown area to create a gradient of enhancement that culminates in the downtown core.
- C.** Artwork should avoid creating obstructions or hazards to pedestrians or motorists and should be well coordinated with the placement of street furnishings, trees, and other amenities.
- D.** Artwork should be placed to provide easy visual access to pedestrians and motorists. Placement should consider views from adjacent buildings and use areas and avoid blocking views to commercial developments and local businesses.
- E.** Plaza spaces, crosswalk bulb-outs, sidewalks, parkways, and medians should all be considered as locations for potential art installations.
- F.** All capital improvement and discretionary development projects should be given identified requirements or incentives such as square footage bonuses to include public art in the right-of-way.

- G.** Art should be incorporated in street furnishings such as benches, bike racks, and bollards wherever possible without disrupting the overall design theming.
- H.** Production of art by local artists should be pursued and encouraged.
- I.** The character of art pieces should increase the legibility and memorability of the downtown area.
- J.** Art pieces that increase an understanding and appreciation of National City's history and culture should be cultivated and incentivized where possible.



Art bike rack in the Portland Oregon downtown area



Interpretive geomap art piece adds interest and depicts the geologic structure and coastline of a region

7.7.10 STREET TREES

Street trees are encouraged throughout all areas of the Planning Area. Consistency of street trees is not important on all streets, but certain streets would benefit from a more unified street tree pattern. The desired streetscape outcome is to establish a hierarchy of streets based on level of use, street size, and function. Non-designated streets can be made up of a mixture of street trees helping the street contrast with the designated streets which would exhibit a more formal and regular pattern.

The following guidelines should be used in conjunction with the streetscape design segments diagram showing the preferred pattern of street trees along with a table of recommended street trees (see Figure 7-16 & Table 7-3). All other areas should be designed per the standards and guidance found in the National City development

standards which are based mostly on available parkway planting widths. Existing street trees, especially of mature character and spread, should always be preserved if possible. With this goal in mind, the recommended street trees specified in Table 7-3 for each street have incorporated the dominant existing tree species currently found on each street.

Trees and landscape plantings are essential to setting and maintaining the character of National City's downtown area. A well-chosen and placed palette of street trees will clarify the importance of each street, assist wayfinding, minimize maintenance and protect the public's investment in National City's urban forest. A strong urban forestry program can improve safety, encourage walking, calm traffic, lower runoff, reduce the urban heat island effect, and improve property values.



Mature street trees in front of historic Brick Row

7.7.10.1 Street Trees Guidelines

Planting guidelines include:

- A.** New development should be sited and designed to mitigate any harmful impacts to major public trees or other significant plant material resources. If unavoidable, then replacement trees and plant material should be installed to provide a minimum of 50 percent of the plant biomass removed during construction.
- B.** Tree selection and landscaping should be used to establish links between blocks and to tie neighborhoods together. On streets designated for specific tree species, existing trees can remain or be selectively removed as deemed necessary to carry through the desired design characteristics. All new plantings should come from the recommended list of unifying and accent tree species.
- C.** Street trees should be spaced on center at an interval equal to the specie's mature canopy. Gaps between the edges of tree canopies greater than 30 feet should be avoided. Trunk to trunk spacing should not be less than 20 feet or greater than 50 feet.
- D.** Street tree spacing should be consistent within a single block to provide rhythm and continuity unless a natural appearance is desired with groupings of mixed species. Where possible, the unifying and accent tree species should either alternate to create a pleasing rhythm and variety or the unifying tree species should be used at the intersections and the accent trees along the lengths of the street between the intersections.
- E.** Triangulation of street trees (using an alternating double-row of trees) is encouraged where sidewalks exceed 10 feet in width to improve the pedestrian experience and provide optimal shade. This would help to emphasize the importance of the street. The outer row of trees should be consistent with single tree spacing, with the second row being the option of the adjacent development.
- F.** Methods of tree installation should be carefully evaluated to ensure the necessary area of non-compacted sub grade sufficient for root growth and drainage is accommodated.
- G.** Trees should be provided with a minimum of 40 square feet of open planting area per tree. This can include covered areas that provide for water and air circulation such as tree grates, Silva Cells, permeable surfaces, and open planter areas. Compacted soils and non-soil materials should not be included in this minimum planting open space requirement
- H.** Structural soils are preferred over compacted soils. Open planters with shrubs and ground-covers are preferred over tree grates. Deep tree-well pits with corner subsurface drainage options are preferred over standard tree wells with the soil types typical of National City which are characterized by low-permeability.
- I.** Driveway aprons that exceed 22 feet should have at least one tree in-between driveways using a raised median in a location appropriate to maintain the intended vehicular traffic flow (See Graphic).
- J.** Chosen tree species should be hearty, tolerant of urban conditions and potential damage from vehicles, pedestrians, and wildlife. Trees should also be suited to the San Diego County coastal climate and minimize the need for significant water, pesticides, or fertilizer to maintain health.
- K.** Tree species should be structurally sound, and not have weak branching habits that result in broken or fallen branches. All street trees must provide a minimum clear zone of 6 feet from the paving surface or finish grade to their lowest limbs.
- L.** Tree species with high branching and open canopy patterns should be prioritized to avoid obscuring businesses and commercial signage. Fast growing trees capable of producing open branching structures should be used along commercial and main streets.

- M.** Tree species with distinctive characteristics should be used for secondary accent trees and trees with uniform growth and background greenery should be used as primary street trees whenever possible.
- N.** Trees that generate large amounts of organic litter should be avoided.
- O.** Tree species with invasive root systems that could create potential conflicts with utility networks should be avoided unless controlled by root barriers or other containment measures.
- P.** Root barriers should be placed at all hard-scape edges within 5 feet of a tree.
- Q.** Street trees should be planted at a minimum caliper of two inches in caliper and have no limbs in a clear-zone extending 6 feet vertically from the paving surface. Trees with lower branching should be limbed-up to remove branches that could block views to businesses and other design elements.
- R.** Maintain street trees minimum once every 5 years to prevent trees overturning or dropping major branches.



Unifying tree placed at intersections with accent trees between



Alternating arrangement of unifying and accent trees



Tree planter island bisects a wide driveway providing continuous tree coverage



Double row of trees at widened sidewalk

Figure 7-16: Streetscape Design Treatments









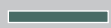
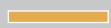

Streetscape Design Segments			Design Guideline District				
Symbol	Street	Limits	"Main Street Type" Retail	Visitor/Education Village	General Commercial	Neighborhood Transition	Civic Center
Main / Commercial Streets							
	8th St.	National City Blvd. - D Ave.	✓				
	National City Blvd.	Division St. - 2nd St.			✓		
	National City Blvd.	2nd St. - 12th St.	✓	✓			
	National City Blvd.	12th St. - 16th St.			✓		
Green Streets							
	9th St.	A Ave. - D Ave.	✓			✓	
	A Ave.	7th St. - National City Blvd.	✓			✓	✓
Multi-Modal Streets							
	7th St.	Roosevelt Ave. - D Ave.	✓	✓		✓	
	8th St.	Hoover Ave. - National City Blvd.		✓		✓	
	Plaza Blvd.	Interstate 5 - D Ave		✓		✓	
	12th St.	Roosevelt Ave. - D Ave.	✓			✓	✓
	Civic Center Dr.	Roosevelt Ave. - National City Blvd.			✓	✓	✓
	Roosevelt Ave.	National City Blvd. - 16th St.	✓	✓	✓	✓	✓
	D Ave.	7th St. - Plaza Blvd.	✓			✓	

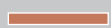

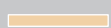
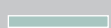
Table 7-3: Recommended Street Trees

Street	Limits	Large Unifying Tree (LU)	Small Unifying Tree (SU)	Large Accent Tree (LA)	Small Accent Tree (SA)
Main / Commercial Streets					
8th St.	National City Blvd. - D Ave.	Brisbane Box	Queen Palm	Purple-Leaf Plum	Western Redbud
National City Blvd.	Division St. - 2nd St.	Date Palm	CA Fan Palm	Saint Mary's Magnolia	Hong Kong Orchid Tree
National City Blvd.	2nd St. - 12th St.	Date Palm	CA Fan Palm	Bradford Pear	Hong Kong Orchid Tree
National City Blvd.	12th St. - 16th St.	Date Palm	CA Fan Palm	Saint Mary's Magnolia	Hong Kong Orchid Tree
Heritage / Green Streets					
9th St.	A Ave. - D Ave.	Chinese Elm	CA Sycamore	Brisbane Box	Saint Mary's Magnolia
A Ave.	7th St. - National City Blvd.	Tipu Tree	Chinese Flame Tree	Brisbane Box	Gold Medallion Tree
Multi-Modal Streets					
7th St.	Roosevelt Ave. - D Ave.	Weeping Bottlebrush	Queen Palm	Purple-Leaf Plum	Western Redbud
8th St.	Hoover Ave. - National City Blvd.	Tipu Tree	Chinese Flame Tree	Brisbane Box	Gold Medallion Tree
Plaza Blvd.	Interstate 5 - D Ave.	Ca Sycamore	Brisbane Box	Purple-Leaf Plum	Western Redbud
12Th St.	Roosevelt Ave. - D Ave.	Date Palm	CA Fan Palm	Purple-Leaf Plum	Western Redbud
Civic Center Dr.	Roosevelt Ave. - National City Blvd.	Brisbane Box	Carrotwood Tree	Purple-Leaf Plum	Western Redbud
Roosevelt Ave.	National City Blvd. - 16th St.	Fern Pine	Brisbane Box	Bradford Pear	Hong Kong Orchid Tree
D Ave.	7th St. - Plaza Blvd.	Fern Pine	Brisbane Box	Bradford Pear	Hong Kong Orchid Tree

Figure 7-17: Street Tree Photos



Bauhinia x blakeana
(Hong Kong Orchid Tree)



Lophostemon confertus
(Brisbane Box)

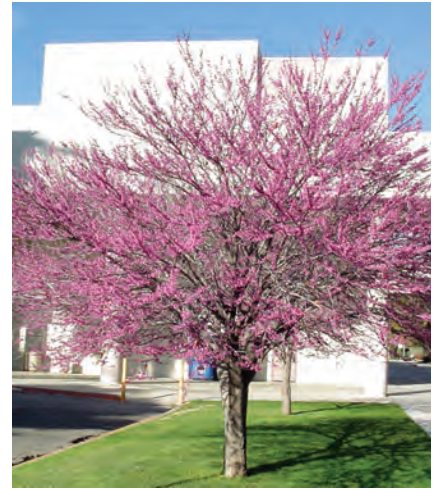

Cercis occidentalis
(Western Redbud)



Cassia leptophylla
(Gold Medallion Tree)



Callistemon viminalis
(Weeping Bottlebrush)



Koelreuteria bipinnata
(Chinese Flame Tree)



Cupaniopsis anacardioides
(Carrotwood Tree)

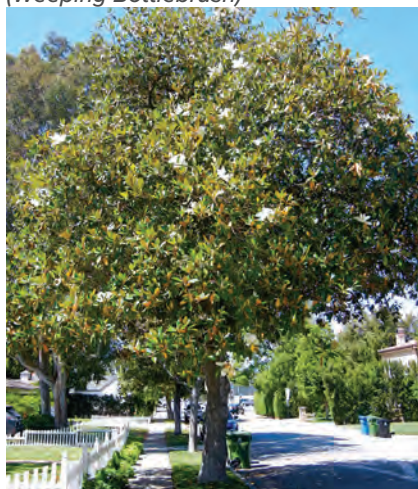

Magnolia grandiflora 'Saint Mary'
(Saint Mary's Magnolia)



Phoenix dactylifera
(Date Palm)

Figure 7-17: Street Tree Photos (Cont.)



Prunus cerasifera 'Krauter Vesuvius'
(Purple-Leaf Plum)



Platanus racemosa
(CA Sycamore)



Tipuana tipu
(Tipu Tree)



Syagrus romanzoffiana
(Queen Palm)



Podocarpus gracilior
(Fern Pine)



Washingtonia filifera
(CA Fan Palm)



Ulmus parvifolia
(Chinese Elm)



Pyrus calleryana
(Bradford Pear)

Page intentionally left blank



FUTURE IMPLEMENTATION PROGRAMS

8

8.1 IMPLEMENTATION STRATEGY

A key element to the Specific Plan is identifying the implementation measures that will result in the desired changes articulated in the Specific Plan. The implementation strategy will guide City staff, property owners, developers, and decision makers in realizing the infrastructure, amenity, and economic development components of the Specific Plan. The strategies and key actions are summarized below:

1. Revise the City's Capital Improvement Program (CIP). – The key action would be for City staff, in consultation with the community and business stakeholders, to reflect the Specific Plan's proposed improvements in the City's annually updated CIP.
2. Promote Public Private Partnerships – Public-private partnerships offer successful means to influence limited resources and achieve mutually desired goals. Increase coordination of funding programs, incentivize economic development, and joint participation in obtaining increased grant and loan opportunities will be needed.
3. Form an Enhanced Infrastructure Financing District – In addition to traditional financing techniques, the implementation of innovative financing techniques will be important. An immediate priority would be to explore the feasibility of establishing an Enhanced Infrastructure Financing District (EIFD) for infrastructure bond financing.
4. Update the City's Development Impact Fee (DIF) Schedule – The key action would be to update the City's development impact fee schedule within the Planning Area to reflect new development's proportionate share of the proposed public infrastructure and amenities. Development impact fees are monetary payments levied on a private developer to fund the public facilities necessary to serve new development. In California, AB 1600 (Mitigation Fee Act), adopted in 1987 and codified as Government Code Section 66000 et seq., formalized the statutory framework that governs impact fees. AB 1600 requires that a reasonable relationship or "nexus" must exist between the amount of the impact fee, its purpose, and the project on which it is imposed and cannot be used to fund preexisting deficiencies.
5. Investigate interest in Establishing a Business Improvement District – A key action would be to explore the idea of establishing either a business-based business improvement district (BPID) or a property-based business improvement district (PBID). A Business Improvement District (BID) is a public/private partnership created to perform marketing and a variety of enhanced services and minor capital improvements to revitalize and improve commercial neighborhoods. In California, there are two types of BIDs, one created through assessments of property owners alone. BIDs can be created to perform a variety of services in commercial districts, including marketing and promotion, sponsorship of public events and ongoing operations and maintenance programs, such as enhanced security, street and sidewalk maintenance, lighting, and signage. While BIDs can finance some minor capital improvements, they cannot be used to finance large scale capital projects, Establishing a BID is voluntary and subject to a majority vote of the property or business owners.
6. Maintenance Assessment District – Investigate if there is interest in forming a Maintenance Assessment District (MAD) for the Planning Area. A MAD typically maintains improvements but may also pay for design, construction, and installation of an improvement. Any MAD funded maintenance or construction improvement must provide a special benefit to property owners. MADs provide higher levels of maintenance services on property owned by the City including public rights-of-way, City-

owned open space, and City-owned parkland or on property with access rights granted to the City including landscape easements, open space easements, or public access easements in favor of the City.

7. Pursue Regional, State, and Federal Infrastructure Funding Sources – A key action would be to identify, monitor, and apply for other governmental funding sources that meet the Specific Plan’s goals and objectives. Examples of grants to pursue at the state and local levels are the Sustainable Community Grant/Active Transportation Grants, the CALTRANS (California Department of Transportation) Sustainable Transportation Planning Grant Program, SANDAG’s TransNet Smart Growth and TransNet Active Transportation Grant Programs, and the California Strategic Growth Council Urban Greening Grants and Sustainable Communities Planning Grants.
8. Provide Financing Incentives to Property Owners for Ongoing Façade Improvements – Continue to incentivize property owners to upgrade their buildings through the use of the City’s Commercial Façade Improvement project. The grant funds will be used to assist business owners in improving the façade of their businesses in downtown National City.

9. Submit for HUD’s Section 108 Economic Development Loan Project – Section 108 of the Federal code offers State and local governments the ability to transform a small portion of their CDBG funds into federally guaranteed loans large enough to revitalize older areas and create economic revitalization projects.
10. Marketing and Outreach – Develop a marketing and outreach program that would advertise the downtown revitalization efforts to National City residents and businesses and the broader region. This marketing program should be coordinated with National City’s Chamber of Commerce.
11. Monitor Fiscal Performance Specific Plan Public Revenues and Economic Development – Public sector revenues will increase as a result of economic development within the Specific Plan. The key action is to monitor fiscal performance in the prime commercial locations to include property and sales taxes, as well as business license taxes, property taxes in-lieu of motor vehicle license fees and other relevant public funds, as identified. Other employment, population, and housing indicators could be monitored, as well.



Page intentionally left blank



9

APPENDICES

9.1 GLOSSARY

Accessible – Public spaces, building, and facilities, which accommodate people with special needs or disabilities.

Accessory Use – A use incidental to, and on the same lot as, a principle use, such as a detached garage apartment on a residential lot.

Adaptive Use – Conversion of a building into a use other than that for which it was designed, such as changing a warehouse into gallery space or housing.

Amenity – Design features, which are valued by the users of a building or public space. Examples of amenities include: good architecture, open space, landscaping, seating, and public art.

Americans with Disabilities Act of 1990 (ADA) – The federal law that requires public buildings and facilities, including transportation facilities, to be accessible to persons with disabilities.

Aquifer – A body of permeable soil and rock that can contain and transmit groundwater.

Art Corridor – A street or pedestrian walkway lined or marked by regular art installations meant to be experienced in a linear or sequential fashion.

Art Intersection – Intersections with artistic paving or other aesthetic treatments

Art Node – A pedestrian space designed for the placement and display of art pieces best viewed at close range from all sides.

Average Daily Trips (ADT) – The average numbers of vehicles passing a fixed point in a 24 hour period. A conventional measurement of traffic volume.

Axis – A real or imaginary straight line around which the parts of a structure or space are symmetrically or evenly arranged or composed.

Best Management Practices – A combination of practices that prevent or reduce the amount of pollution generated by nonpoint sources to achieve acceptable water quality levels.

Bikeway – A facility intended to accommodate bicycle travel for recreational or commuting purposes.

Build-to-Line – A zoning device that controls the location of buildings to create consistent street-walls or define public spaces. Unlike a setback, which establishes a minimum distance from a property line or street, a build-to-line establishes the maximum permitted setback or exact location of a building façade.

Bulb-Out – See Curb Extension definition.

Build Out – The maximum allowable area as stipulated by land use controls like zoning or a building cap.

Bulk – (see mass)

CBC (California Building Code) – Building regulations enforced within the state of California.

Charrette – A French term used to describe an intensive, collaborative design exercise that generates ideas for a project or plan.

Circulation – Movement patterns of pedestrians and vehicular traffic.

Cluster Development – A land planning technique to concentrate buildings and other built elements on a portion of a site in order to preserve open space and environmentally sensitive areas.

Collaboration – A team effort with contribution from professionals in different fields, such as architects, landscape architects, engineers, artists and other interested parties.

Colonnade – A linked row of columns providing shade and protected passage.

Compatibility – The characteristic of different designs that allow them to be located near each other in harmony, such as scale, height, materials, fenestration, etc.

Controlled Intersection – Intersections with traffic lights, stop signs, or yield signs to control traffic.

Cornice – The top of a wall or building element made evident by an assembly of projecting moldings which strike a definitive limit to that section of the building.

CPTED (Crime Prevention Through Environmental Design) – A multidisciplinary approach to deterring criminal behavior through environmental design.

Curb Extension – Also known as a neckdown, bulb-out, or bump-out, a curb extension is a traffic calming measure that extends the sidewalk into the roadway at intersections, reducing the crossing distance and improving visibility of pedestrians and motorists at intersections.

Density – A measurement of the number of units, e.g. housing or persons per acre, which may indicate the level of activity in an area (see illustration in Section III).

Design Guidelines – A tool that defines appropriate architectural and urban design responses in specific areas of a city. Design guidelines have been used as the basis for the review of development proposals in historic areas, special districts, and planned unit development.

Design Storm – A rainfall event category (typically 50-year or 100-year) that is used for assessing the required conveyance volume capacity of storm-water infrastructure elements such as gutters and drains.

Directional Emphasis – Refers to a predominant emphasis of the building, either horizontal or vertical. Recognizing this aspect of design is especially important when designing additions to historic buildings or when planning a new development in a historic district.

District – An area that has a distinct character or purpose, such as an area with predominantly historic buildings, arts facilities, ethnic residents, or unique topography.

Easement – A less-than-fee interest in real property acquired through donation or purchase and carried as a deed restriction or covenant to protect important open spaces, sensitive natural resources, views, building façades, or interiors.

Edges – Delineation of districts or areas, which could be physical in nature (e.g. freeways or greenbelts) or psychological (e.g. major streets joining residential and commercial districts). Hard edges create a break between areas. Freeways and busy thoroughfares are generally disruptive hard edges, which create a physical or psychological barrier. Soft edges create a subtle break or transition between areas or uses and, unlike hard edges, are not particularly difficult to cross. For instance, a plaza, park or a non-offensive change in land use is considered a soft edge.

Elevation – A two-dimensional drawing that illustrates the vertical plane of an object or building. A drawing of a building's façade is an elevation. (See architectural drawings)

Façade – The exterior wall of a building exposed to public view or that wall viewed by persons not within the building.

FAR (Floor Area Ratio) – A formula for determining permitted building volume as a multiple of the area of the lot. The FAR is determined by dividing the gross floor area of buildings on a lot by the area of the lot. For example, a FAR of 6 on a 5,000 square foot lot would allow a building with a gross area of 30,000 square feet.

Fenestration – Design elements of the exterior (architectural) window treatments such as pattern, rhythm and ornamentation.

Filterra – A storm-water filtration system that uses a bio-filter to capture and treat pollutants in water before discharging it into a storm drain system.

Form-Based Code – A new and useful implementation measure, emphasizing building forms over individual land uses, for achieving certain planning goals, such as walkable neighborhoods and mixed-use and transit-oriented development.

Grid – A traditional method of land subdivision which results in the creation of square or rectangular blocks and public streets that intersect at right angles.

Groundwater – Water held underground in the soil or in pores and crevices in the rock.

Historic District – A geographically definable area with a significant concentration of building, structures, sites, spaces or objects unified by past events, physical development, design, setting, materials, workmanship, sense of cohesiveness or related historical and aesthetic associations. The significance of a district may be recognized through listing in a local, state or national landmarks register and may be protected legally through listing in a local, state or national landmarks register and may be protected legally through enactment of a local historic district ordinance administered by a historic district board or commission.

Historic Structure – For the purposes of the federal preservation tax incentives, any structure subject to depreciation as defined by the Internal Revenue Code that is listed individually in the National Register of Historic Places or located in a registered historic district and certified by the Secretary of the Interior as being of historical significance to the district.

Infill – Housing or other development in an urban area that is designed to fill a void left by vacant property, such as redevelopment land. Generally, the purpose of infill is to revitalize the surrounding area.

Landmark – 1) A structure or feature of historic, cultural or architectural significance (see Historic Structure) or 2) an object that is useful for orientation.

Level of Service – A measure indicating the types of facilities/amenities and their characteristics that should be provided in a vehicular, bicycle, pedestrian or other space based on analysis of demand, traffic-levels, and other factors.

Mapping – Technique used for communicating information about the physical environment. Maps may represent physical features such as land and climate conditions or abstract concepts such as view corridors and pedestrian nodes.

Mass – A term used to describe the three dimensional form or bulk of a building.

NEV (Neighborhood Electric Vehicle) – A battery powered electric vehicle usually built to have a maximum speed of 25 miles per hour.

Node – A hub of activity.

Paseo - A pathway set aside for walking.

Parking Demand Ratio – The ratio that determines the number of parking spaces per unit of land that are required by the City.

Peak Parking Demand Ratio – The projected parking demand ratio required to provide enough parking spaces for periods of peak parking demand.

Pediment – The triangular face of a gable.

Percolation Rate – The water absorption rate of a soil usually expressed in inches per hour.

Pocket Park – A small park in an urban area.

Preservation – Providing for the continued use of deteriorated old and historic buildings, sites, structures and objects. The means for preservation include restoration, rehabilitation and adaptive use.

Proportion – The ratio or relative size of two or more dimensions. The term can be used to refer to the ratio of the width to the height of a door or window opening, or to the ratio of the width of a street to the height of adjacent buildings.

Public Art – Works of art that are located in public space. Public art may exist in a variety of forms, from freestanding sculpture to well-crafted street lights and benches.

Reconstruction – The act or process of reproducing by new construction the exact form and detail of a vanished building, structure, or a part thereof, as it appeared at a specific period of time.

Rehabilitation – (see Preservation)

Renovation – Modernization of an old or historic structure. Unlike restoration, renovation may not be consistent with the original design.

Residential – Occupancy of any type of building and not limited to high-rise, mid-rise, low-rise, multifamily attached or single-family detached and sleeping accommodations are provided for, except those classified under institutional or transient.

Rhythm and Pattern – Relate to materials, styles, shapes and spacing of building elements and the buildings themselves. The predominance of one material or shape, and its patterns of recurrence, is characteristics of an area that need to be maintained.

Restoration – (see Preservation)

Scale – The apparent size of a building, window or other element as perceived in relation to the size of a human being. Scale refers to the apparent size, not actual size, since it is always viewed in relationship to another building or element. For instance, the scale of one element may be altered simply by changing the size of an element nearby, such as windows, doors, or other architectural details. These relationships contribute to the experience of a place as intimate, vast, and daunting, etc.

Scenic Easement – A restriction on the use of land or buildings to protect an important view or scenic corridor.

Shopkeeper Unit – A dwelling unit with both living quarters and commercial space that meet all occupancy separation requirements of the California Building Code, where the commercial use is located on the ground floor and operated by the resident of the dwelling unit.

Silva Cells – A modular suspended pavement system that uses soil volumes to support large tree growth and provide powerful on-site storm-water management through absorption, evapotranspiration, and interception.

Site Plan – A plan prepared to scale, shown accurately and with complete dimensioning, the boundaries of a site and the location of all buildings, structures, uses, and principal site design features proposed for a specific area and parcel of land.

Street Furniture – Municipal equipment placed along streets, including light fixtures, fire hydrants, police and fire call boxes, trash receptacles, signs, benches, newspaper boxes, and kiosks.

Streetscape – The distinguishing character of a particular street as created by its width, degree of curvature, paving materials, design of the street furniture, and forms of surrounding buildings.

Streetwall – The building frontage and façade that defines the public space edge of the sidewalk, streetscape, and street.

Structural Soil – A constructed soil type made up of gap-graded gravels, clay loam, and a hydrogel stabilizing agent. This medium allows for the compaction required for pavement design and provides the air spaces required for plant root growth and the storage of rainwater during storm events.

Sub-Surface Runoff – Storm-water that infiltrates and moves through the soil both horizontally and vertically.

Surface Runoff – Surface water that moves on the ground by gravity.

Townscape – The relationships among buildings, public spaces, and land forms that gives a town or area a distinct visual character or image.

Traditional Neighborhood Development (TND) – A compact, pedestrian-oriented development with a mix of uses, walkable, compact, convenient services, and well defined public and private spaces.

Traffic Calming – The deliberate slowing of traffic through the use of design elements for the purpose of encouraging a safer environment for all transportation types.

Transparency – Refers to the interaction between observer and an activity in an environment. It allows the observer to "read" what is happening inside a structure or in another area. For example, a commercial building is considered transparent if the pedestrian can view the merchandise or interior activity from the street.

Urban Fabric – The physical material of a building, structure or city, connoting an interweaving of component parts.

Vernacular – Landscape, settlement patterns, and building types which result from local or regional building traditions and conventions.

View Corridor and View Shed – Refers to the line or range of vision from an observation point to a viewpoint, often used in determining the extent of scenic easements.

9.2 NATIONAL CITY DOWNTOWN PARKING ACTION PLAN



National City Downtown Parking Action Plan

June 2017

Introduction

National City's dense and compact urban form makes it a suitable environment for mixed-use and pedestrian friendly-development, and the urban core is well-served by multi-modal transportation options including public transit service that allows for many local and regional trips to be made without a car. National City desires to build on these existing assets and investments by pursuing "smart growth" planning and infrastructure policies to incentivize development patterns that are more environmentally and financially sustainable. By encouraging new development to occur around existing public transit nodes and bike/pedestrian infrastructure, National City is endeavoring to better accommodate projected future growth while minimizing quality of life impacts (e.g. traffic congestion) and fiscal impacts (e.g. new road infrastructure) associated with conventional, auto-dependent, sprawling development.

In order to achieve its smart growth vision, the City is undertaking a number of initiatives, including preparation of a comprehensive Parking Management Plan as part of an update to the Downtown Specific Plan. In order to provide a proactive approach to parking management for Downtown National City, the following Parking Action Plan or "PAP" has been prepared to initiate the first phase of implementation. The PAP is designed as a two-year parking pilot program that considers unique local conditions and national best practices to address existing and future parking demand.

PAP Strategies

The following parking management strategies are recommended for implementation over the next two years as part of a pilot program for Downtown National City:

Parking Enforcement

- Route Management – develop a schedule to maximize coverage and frequency considering existing staff resources and hierarchy of duties to ensure consistent and efficient enforcement
- Enforcement Technology – purchase new electric parking enforcement vehicle equipped with license plate recognition technology to provide more efficient parking enforcement

Parking Capacity

- Angled Parking – convert parallel parking to angled parking to increase parking capacity
- Oversized Vehicle Parking Prohibitions – prohibit oversized vehicle parking on Roosevelt Avenue to increase parking capacity for employees and customers of local business and future residents

Parking Utilization

- Online Permit Parking Management System – implement online system to better facilitate issuance of parking permits, customer service and database management

- Residential Permit Parking – expand residential permit parking zones within the neighborhoods north and south of E. 8th Street to reduce spillover parking from businesses along E. 8th Street
- Parking Meters – install single space parking meters on E. 8th Street between National City Blvd and “D” Avenue, and “A” Avenue between E. 7th Street and E. 9th Street to increase parking turnover for local businesses and allow for more efficient enforcement

Parking Enforcement

Consistent and efficient parking enforcement is critical to ensuring an effective parking management system. Inconsistent time restricted parking zones and lack of new technology has negatively impacted parking enforcement in Downtown National City. National City parking enforcement officers have recently transitioned to using handheld devices to expedite the process of issuing citations. The PAP recommends upgrading to the latest technology that links the handheld devices to an intuitive backend system to automate the citation process.

In addition, the PAP recommends purchasing a new electric parking enforcement vehicle equipped with license plate recognition (LPR) technology. LPR technology allows for more efficient parking enforcement by simply scanning license plates and time stamping the images to verify whether or not parked vehicles have exceeded posted time restrictions. This technology, coupled with the new handheld devices and backend system, will allow parking enforcement officers to cover more zones in less time to ensure frequent, efficient enforcement.

Parking Capacity

Recent parking surveys within the residential neighborhoods north and south of E. 8th Street identified opportunities to expand parking capacity by converting parallel parking to angled parking. The PAP recommends striping angled parking on one side of the street consistent with the locations illustrated in Figure 1, which would result in a net gain of approximately 220 on-street parking spaces.

As illustrated in Figure 2, the PAP also recommends prohibiting oversized vehicle parking on Roosevelt Avenue to increase parking capacity for employees and customers of local business, and future residents.

Parking Utilization

Maximizing parking utilization is a key component to a successful parking management program. The approach consists of implementing a variety of parking strategies to increase access to local businesses during the day, while providing overnight parking for residents after business hours. The PAP recommends implementing parking meters in business districts, combined with time restricted parking zones within one block of the meters and residential permit parking for the surrounding neighborhoods. These strategies should be implemented simultaneously, and only after ensuring appropriate resources are in place to provide consistent and effective enforcement, in order to ensure a successful pilot program.

The locations for installation of single space parking meters are illustrated in Figure 3. Single space parking meters are warranted based on the results of recent parking surveys which

indicate existing parking occupancy ratios of 80% or greater during peak periods. Figure 4 illustrates the proposed locations for expansion of residential permit parking.

The PAP also recommends implementing an online permit parking management system to better facilitate issuance of parking permits, customer service and database management. The residential parking permits would be digitally linked to the LPR system using the license plates as the identifier. This will allow for more efficient enforcement and management.

A fee structure for the meters and residential parking permits will be established based on review of similar programs implemented by other cities in the San Diego region, while taking into account unique local conditions and national best practices. The establishment of residential permit parking district boundaries and fee structures for meters and permits will be presented as part of a new parking ordinance for the Downtown Specific Plan Area, which will go through a formal public hearing process.

Public Outreach

Extensive data collection (referenced above) and public outreach activities such as public surveys, City Council presentations, workshops and open house events, have been provided as part of the Downtown Specific Plan Update, which also includes preparation of a comprehensive Parking Management Plan. These efforts have led to the development of the PAP as a pilot program to evaluate implementation of new parking management strategies for National City's Downtown. Additional research, data collection and public outreach will continue as part of the pilot program.

PAP Implementation Schedule

As previously stated, the PAP pilot is anticipated to be a two-year program. All of the parking management strategies outlined above will be phased in during the first year, which provides for a minimum of one full year of evaluation to determine the effectiveness of the program. Those elements of the PAP such as adopting fee schedules and establishing residential permit parking district boundaries, which require subsequent City Council action, will go through the appropriate public notification and hearing processes.

Figure 1 – Locations for Conversion of Parallel Parking to Angled Parking

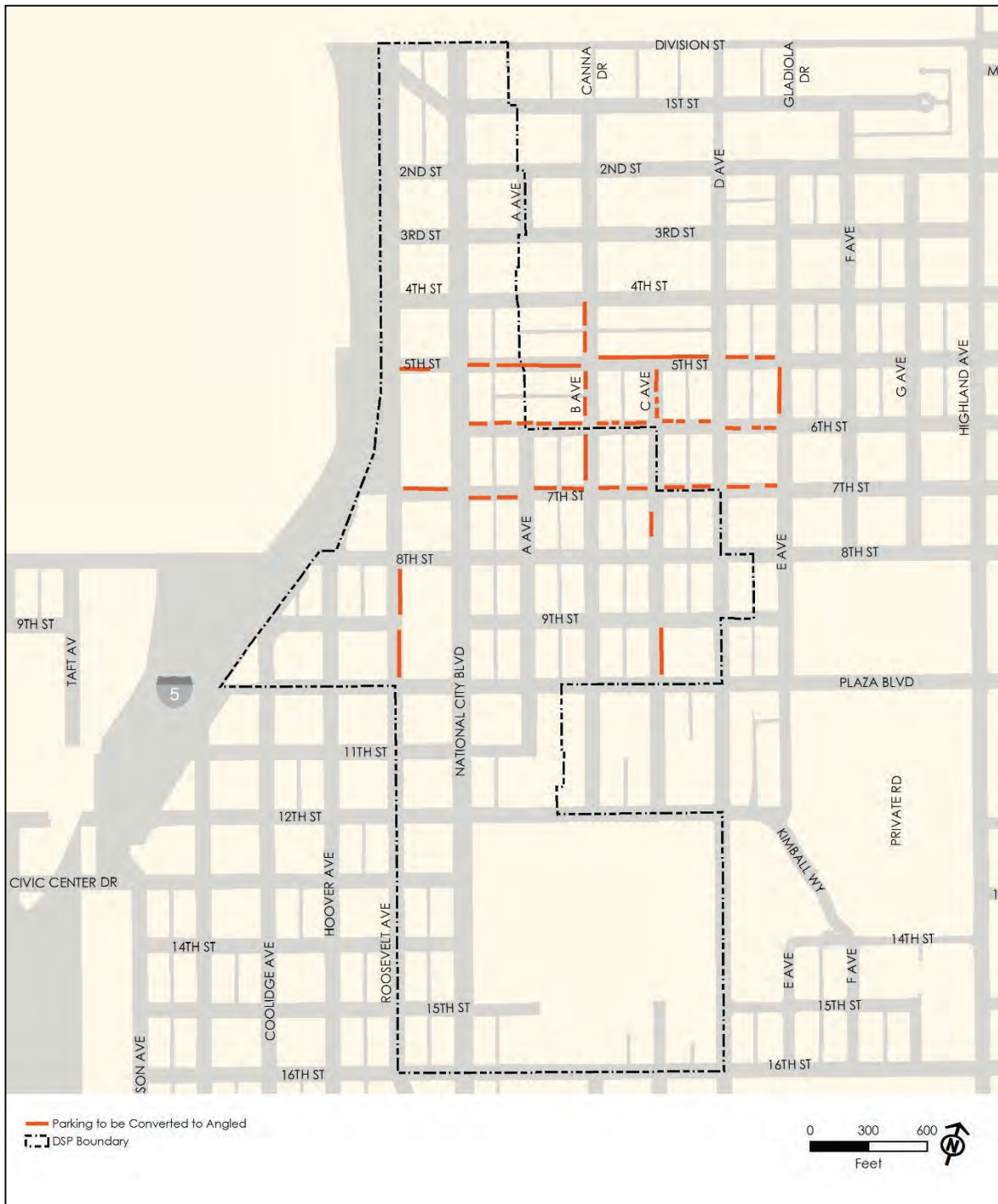

Figure 2 – Locations for Oversized Vehicle Parking Prohibitions

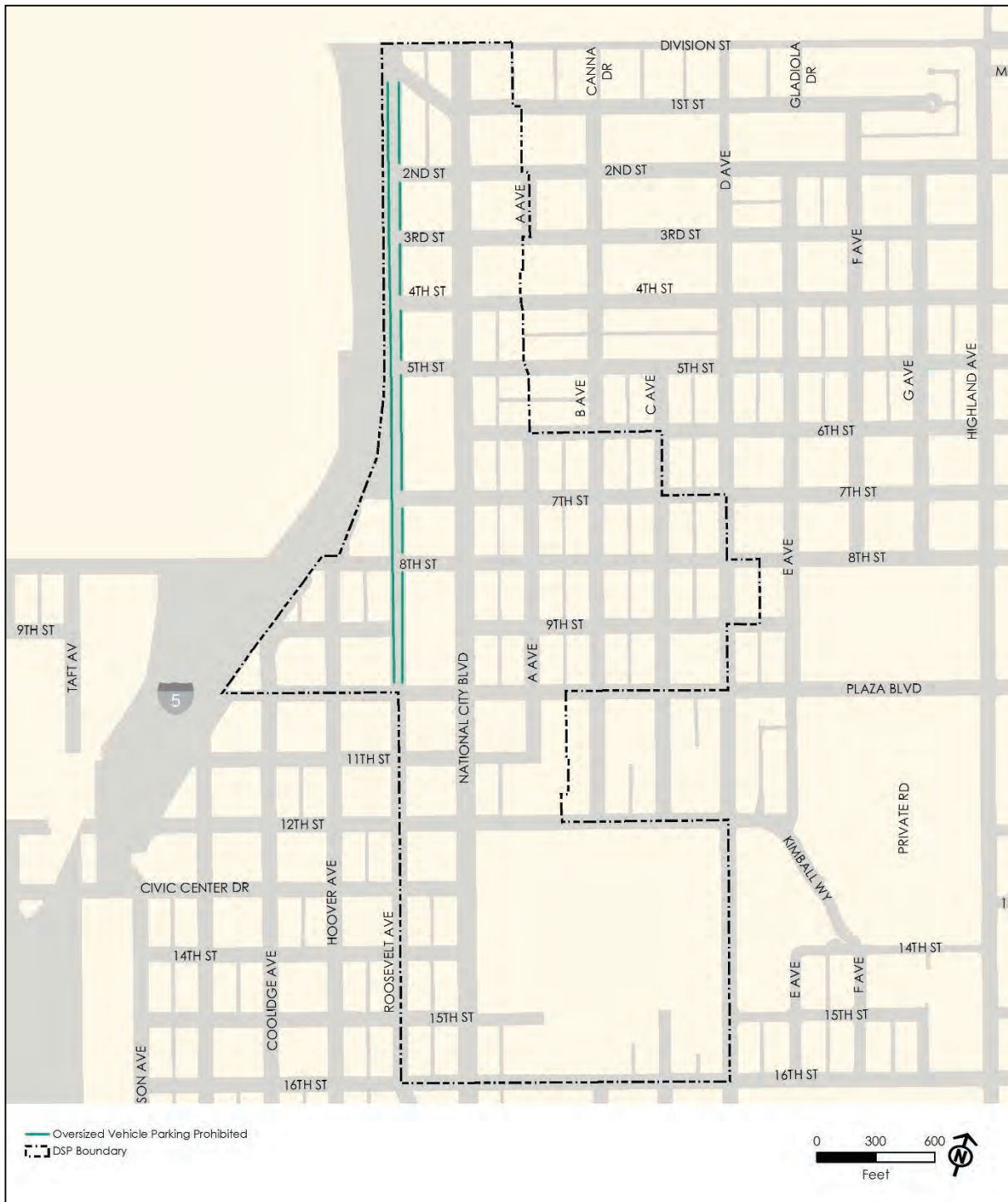

Figure 3 – Locations for Single Space Parking Meters and Time Restricted Parking

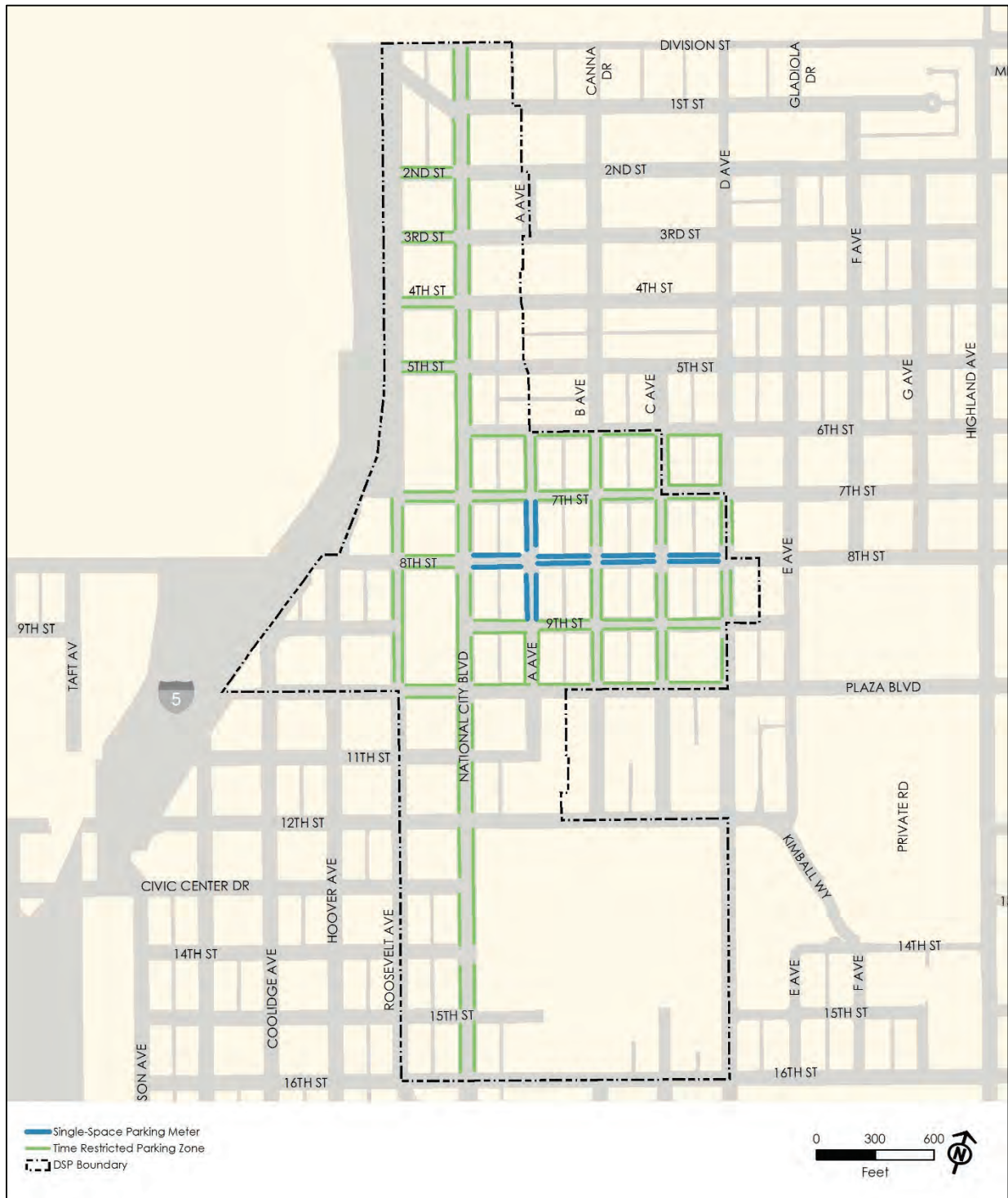

Figure 4 – Locations for Expansion of Residential Permit Parking

